

***Live Streaming/Telecast:** Please note that Public Meetings held in the Council Chamber are being recorded and broadcasted as well included on the City's website at: www.whiterockcity.ca

Corporate Administration
E-mail

(604) 541-2212
clerksoffice@whiterockcity.ca

THE CORPORATION OF THE
CITY OF WHITE ROCK
15322 BUENA VISTA AVENUE, WHITE ROCK, B.C. V4B 1Y6

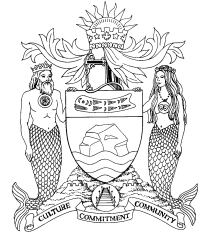

January 8, 2020

ON TABLE see page 226

A **REGULAR MEETING** of CITY COUNCIL will be held in the **CITY HALL COUNCIL CHAMBERS** located at **15322 Buena Vista Avenue, White Rock, BC**, on **MONDAY, JANUARY 13, 2020** to begin at **7:00 p.m.** for the transaction of business as listed below.

T. Arthur, Director of Corporate Administration

A G E N D A

1. CALL MEETING TO ORDER

2. ADOPTION OF AGENDA

RECOMMENDATION

THAT the Corporation of the City of White Rock Council adopt the agenda for its regular meeting scheduled for January 13, 2020 as circulated.

3. ADOPTION OF MINUTES

a) December 16, 2019

Page 10

RECOMMENDATION

THAT the Corporation of the City of White Rock Council adopt the following meeting minutes as circulated:

a) December 16, 2019

4. QUESTION AND ANSWER PERIOD

Question and Answer period is an opportunity for the public to ask questions and make comments. There will be a Speaker's List available, each speaker will be given two (2) minutes and one (1) opportunity to ask a question(s) or make a comment. Question period shall be 15 minutes. Question and Answer Period is noted in the record and once the minutes are adopted, the questions and answers will be available on the [Question and Answer Period webpage](#).

Note: there are to be no questions or comments on a matter that will be the subject of a public hearing (time between the public hearing and final consideration of the bylaw).

4.1 CHAIRPERSON CALLS FOR SPEAKERS TO QUESTION AND ANSWER PERIOD

5. DELEGATIONS AND PETITIONS

5.1 DELEGATIONS

5.1.1 STEPHANIE BECK & GEOFF FUNKE, PEACE ARCH HOSPITAL AND COMMUNITY HEALTH FOUNDATION

S. Beck, Executive Director, and G. Funke, Board Chairperson, to appear as a delegation to provide an update regarding the Peace Arch Hospital and Community Health Foundation.

5.2 PETITIONS

None

6. PRESENTATIONS AND CORPORATE REPORTS

6.1 PRESENTATIONS

None

6.2 CORPORATE REPORTS

6.2.1 CAO RECRUITMENT EXECUTIE SEARCH FIRM CONTRACT AWARD Page 21

Corporate report dated January 13, 2020 from the Director of Human Resources titled “CAO Recruitment Executive Search Firm Contract Award”.

RECOMMENDATION

THAT Council:

1. Receive for information the corporate report dated January 13 2020 from the Director of Human Resources titled “CAO Recruitment Executive Search Firm Contract Award; and
2. Authorize staff to award a contract for a CAO recruitment outreach services to the executive search firm Waterhouse Executive Search at a professional fee of \$18,500.

6.2.2 PATENT SUBMISSION FOR THE WHITE ROCK WATER TREATMENT PLANT

Corporate report dated January 13, 2020 from the Manager of Utilities titled “Patent Submission for the White Rock Water Treatment Plant”.

Page 23

RECOMMENDATION

THAT Council:

1. Receive for information the corporate report dated January 13, 2020, from the Manager, Utilities; Patent Submission for the Water Treatment Plant; and
2. Approve the request to proceed with the submission of a Patent for the Water Treatment Plant.

6.2.3 RESPONSE TO METRO VANCOUVER 2040: SHAPING OUR FUTURE GREENHOUSE GAS EMISSION TARGETS AMENDMENT REQUEST Page 27

Corporate report dated January 1, 2020 from the Director of Planning and Development Services titled “Response to *Metro Vancouver 2040: Shaping our Future* Greenhouse Gas Emission Targets Amendment Request”.

RECOMMENDATION

THAT Council:

1. Receive for information the corporate report dated January 13, 2020 from the Director of Planning and Development Services titled “Response to *Metro Vancouver 2040: Shaping our Future* Greenhouse Gas Emission Targets Amendment Request;” and
2. Authorize the Director of Corporate Administration to respond to the Metro Vancouver Board stating that the City does not object to the proposed amendment to the Regional Growth Strategy, and by sending Council commentary and any applicable resolution along with this corporate report as a response to the Metro Vancouver Board request for comment.

6.2.4 SEA FESTIVAL SURVEY RESULTS Page 39

Corporate report dated January 13, 2020 from the Director of Recreation and Culture titled “Sea Festival Survey Results”.

RECOMMENDATION

THAT Council receive the corporate report dated January 13, 2020 from the Director of Recreation and Culture titled “Sea Festival Survey Results”.

6.2.5 WHITE ROCK LAWN BOWLING CLUB LOAN REQUEST Page 52

Corporate report dated January 13, 2020 from the Director of Financial Services titled “White Rock Lawn Bowling Club Loan Request”.

RECOMMENDATION

THAT Council consider the information presented in this corporate report and:

1. Confirm if Council intends to:
 - a. Enter into a partnering agreement with the White Rock Lawn Bowling Club;
 - b. Extend the licence with the White Rock Lawn Bowling Club; and
 - c. Lend the White Rock Lawn Bowling Club an amount of \$62,000 to assist in the financing of the replacement of its artificial turf, subject to undertaking the legislative processes described in this corporate report; and
2. If Council intends to lend \$62,000 to the White Rock Lawn Bowling Club for this purpose, direct staff to proceed with the next steps as outlined in this corporate report.

- 6.2.6 REVENUE ANTICIPATION BORROWING BYLAW, 2020, NO. 2324 **Page 64****
Corporate report dated January 13, 2019 from the Director of Financial Services titled “Revenue Anticipation Borrowing Bylaw, 2020, No. 2324”.

RECOMMENDATION

THAT Council receive for information the corporate report dated January 13, 2020 from the Director of Financial Services, titled “Revenue Anticipation Borrowing Bylaw, 2020, No. 2324.”

***Note:** The subject bylaw is on this agenda for consideration under the Bylaws Item 8.1.1.*

- 6.2.7 CLIMATE ACTION INITIATIVES **Page 66****
Corporate report from the Director of Engineering and Municipal Operations titled “Climate Action Initiatives”.

Click here for additional info for item 6.2.7 and 7.2c

RECOMMENDATION

THAT Council:

1. Receive for information the corporate report dated January 13, 2020 from the Director of Engineering & Municipal Operations titled “Climate Action Initiatives”;
2. Endorse the ongoing initiatives discussed in this corporate report;
3. Consider including \$15,000, funded from an operating reserve or the City’s accumulated surplus, to fund a top up to the Provincial Better Homes Plan as part of upcoming financial deliberations of the 2020 – 2024 Financial Plan; and
4. Consider including \$20,000, funded from Climate Action Revenue Incentive Program (CARIP) grants to cover the installation of one new electric vehicle charging station with two ports as part of upcoming financial deliberations of the 2020 – 2024 Financial Plan.

- 6.2.8 CITY HALL – SEISMIC REPORT - 2020 **Page 80****
Corporate report dated January 13, 2020 from the Director of Engineering and Municipal Operations titled “City Hall – Seismic Report – 2020”.

RECOMMENDATION

THAT Council:

1. Receive for information the corporate report dated January 13, 2020 from the Director of Engineering and Municipal Operations titled “City Hall – Seismic Report - 2020”;
2. Endorse the retention of a consultant to evaluate options for the future of White Rock City Hall; and
3. Endorse the development of a 5-year implementation plan for the future of White Rock City Hall as well as the civic precinct.

7. MINUTES AND RECOMMENDATIONS OF COMMITTEES

7.1 STANDING AND SELECT COMMITTEE MINUTES

- Governance and Legislation Committee – October 11, 2019 **Page 108**
- Governance and Legislation Committee – October 29, 2019 **Page 110**
- Governance and Legislation Committee – November 18, 2019 **Page 117**
- Governance and Legislation Committee – November 27, 2019 **Page 121**

- Governance and Legislation Committee – December 16, 2019 **Page 126**
- Land Use and Planning Committee – December 16, 2019 **Page 131**
- Finance and Audit Committee – December 9 and continued on Dec 12, 2019; **Page 133**
- Public Art Advisory Committee – November 28, 2019 **Page 147**
- Environmental Advisory Committee – December 5, 2019 **Page 154**

RECOMMENDATION

THAT Council receive for information the following standing and select committee meeting minutes as circulated:

- a) Governance and Legislation Committee – October 11, 2019;
- b) Governance and Legislation Committee – October 29, 2019;
- c) Governance and Legislation Committee – November 18, 2019;
- d) Governance and Legislation Committee – November 27, 2019;
- e) Governance and Legislation Committee – December 16, 2019;
- f) Land Use and Planning Committee – December 16, 2019;
- g) Finance and Audit Committee – December 9 and continued on Dec 12, 2019;
- h) Public Art Advisory Committee – November 28, 2019; and
- i) Environmental Advisory Committee – December 5, 2019

7.2 STANDING AND SELECT COMMITTEE RECOMMENDATIONS

- a) The following recommendation has been brought forward from the **Governance and Legislation Committee** meeting held on December 16, 2019: **Page 160**

RECOMMENDATION: SOCIAL MEDIA POLICY NO. 136

Social Media Policy No. 136 was introduced at the December 16, 2019 Governance and Legislation Committee meeting and is presented for Council’s endorsement:

THAT Council endorse Policy 136: *Managing the City of White Rock’s Social Media Presence* as circulated.

- b) The following recommendations have been brought forward from the **Public Art Advisory Committee** meeting held on November 28, 2019:

RECOMMENDATION #1: BAHAIS GATES OF PARADISE ART DONATION

THAT the Public Art Advisory Committee recommends that, in keeping with the Public Art Policy, Council consider not accepting the art donation titled *Gates of Paradise* into the permanent City Collection; and,

THAT instead, the gift be showcased in a multi-faith themed art showcase.

Note: The City / Council will often accept donations as a courtesy. The location to display such items is discretionary, they may be placed in a public or nonpublic location.

RECOMMENDATION #2: POLICY 708 – PUBLIC ART POLICY

Page 164

THAT the Public Art Advisory Committee recommends amending Policy 708 – Public Art, under section 3.1 (City Public Art Program) to include the following as an additional Item f):

- When calling for artists, the selection committee will endeavor to select, where possible, local artists from White Rock, South Surrey, or Semiahmoo First Nations.

AND THAT the Public Art Advisory Committee recommends that Council approves the Public Art Policy 708 with the proposed amendments.

***Note:** For reference, Council Policy No. 708 is attached with the proposed changes outlined in red in relation to the original policy wording.*

- c) The following recommendation has been brought forward from the **Environmental Advisory Committee** meeting held on December 5, 2019:

RECOMMENDATION: CLIMATE EMERGENCY

THAT the Environmental Advisory Committee requests that Council:

Joins other jurisdictions of Metro Vancouver in recognizing the “climate emergency” arising from critical threats that climate change poses on multiple fronts to regional ecosystems, city infrastructure and the well-being of White Rock’s citizens,

Declares its determination to ensure that the critical interests of White Rock and its citizens are protected and advanced in the fullest possible measure through the City’s climate change mitigation and adaptation strategies,

Requests the Environmental Advisory Committee, working with staff:

- (a) In the context of its mandated review of the Environmental Strategic Plan, to give priority consideration to that Plan’s climate change-related elements, and in so doing to consider also the 2010 Community Climate Action Plan and climate change-related elements of the 2017 OCP.
- (b) To recommend updated emission reduction targets, aligned with targets established by Metro Vancouver in July 2019, and consistent with current provincial and federal goals and the latest IPCC work.
- (c) To recommend steps, including appropriate public consultation measures, to ensure that the City’s climate change goals, policies and actions are updated and consolidated into the Official Community Plan as part of the ongoing OCP review exercise.

Directs staff to:

- (a) Ensure that climate change mitigation and adaptation considerations are mainstreamed into decision-making and operations across all City departments and that climate change impact assessments expressly figure in all reports and recommendations to Council,
- (b) Keep Council apprised of work by Metro officials and committees to develop regional Climate 2050 Roadmaps, and of opportunities and requirements to ensure the City’s interests and perspectives are taken into account in the Roadmaps process,

[Click here for additional info for item 6.2.7 and 7.2c](#)

- (c) Advise Council of any organizational, human resource or financial requirements deemed necessary to ensure the effective implementation of this resolution, as well as opportunities to take advantage of regional, provincial and extra-governmental resources available to inform and support our climate change efforts,
- (d) Keep Council regularly informed of progress in the implementation of this resolution, including through briefings on the City’s annual reports to the Province’s Climate Action Revenue Incentive Program (CARIP).

8. BYLAWS AND PERMITS

8.1 BYLAWS

8.1.1 BYLAW 2324 - WHITE ROCK REVENUE ANTICIPATION BORROWING BYLAW, 2020, NO. 2324 Page 186

As per section 177 of the *Community Charter*, it is recommended that Bylaw 2324 be adopted in the event that the City has to borrow funds to meet 2020 expenditures prior to the collection of property taxes. This bylaw is presented for consideration of first, second, and third reading.

RECOMMENDATION

THAT Council give first, second, and third reading to “*White Rock Revenue Anticipation Borrowing Bylaw, 2020, No. 2324*”.

8.1.2 BYLAWS AND PERMITS (CANNABIS RETAIL) PRESENTED AT THE LAND USE AND PLANNING COMMITTEE HELD EARLIER IN THE EVENING

Bylaws 2323 and 2320 are presented for consideration of first and second reading. If the readings are granted, recommendations to forward these matters to their respective meetings are noted on the agenda for consideration below.

***Note:** These bylaws were the subject of a Land Use and Planning Committee meeting held earlier in the evening. Council may, at this time, choose to consider the following recommendations or defer consideration until the next Regular meeting.*

***Note:** If Council directs staff to schedule the public hearings and public meetings for all three (3) applications, there would be four (4) Public Hearings/Meetings scheduled, as follows:*

1. *Public Hearing for Bylaw No. 2320 - for 15177 Thrift Avenue application from the BCLiquor Distribution Branch, and minimum distance for sale of cannabis accessories from cannabis stores*
2. *Public Hearing for Bylaw No. 2323 to amend general zoning regulation that requires a 1000 metre separation between cannabis stores and has the effect of limiting the number of cannabis stores to one in the Town Centre*
3. *Public Hearing/Meeting for TUP No. 19-012, DVP No. 426, and Cannabis Licence Resolution Request 19-012 – for 1484 Johnston Road application from A Little Bud Cannabis*
4. *Public Hearing/Meeting for TUP No. 19-014 and Cannabis License Resolution Request 19-014 – for 1550 Johnston Road application from Choom BC*

THAT Council give first and second readings to “*White Rock Zoning Bylaw, 2012, No. 2000, Amendment (CD-16 – Cannabis Retail) Bylaw, 2019, No. 2320*”.

RECOMMENDATION #2: PUBLIC HEARING FOR BYLAW 2320

THAT Council direct staff to schedule the required Public Hearing for the zoning amendment application at 15177 Thrift Avenue (Bylaw No. 2320).

RECOMMENDATION #3: PUBLIC HEARING FOR BYLAW 2323

Page 189

THAT Council give first and second readings to “*White Rock Zoning Bylaw, 2012, No. 2000, Amendment (Cannabis Store Separations) Bylaw, 2020, No. 2323*”.

RECOMMENDATION #4: PUBLIC HEARING FOR BYLAW 2323

THAT Council direct staff to schedule the required Public Hearing for “*White Rock Zoning Bylaw, 2012, No. 2000, Amendment (Cannabis Store Separations) Bylaw, 2020, No. 2323*”.

RECOMMENDATION #5: PUBLIC MEETING FOR DVP NO. 426 & TUP NO. 19-012

THAT Council direct staff to schedule the required Public Meeting for Development Variance Permit No. 426 and Temporary Use Permit 19-012, in conjunction with the Public Hearing for Cannabis Licence Resolution Request 19-012 for 1484 Johnston Road.

Page 190

RECOMMENDATION #6: PUBLIC MEETING FOR TUP NO. 19-014

THAT Council direct staff to schedule the required Public Meeting for Temporary Use Permit 19-014 in conjunction with the Public Hearing for Cannabis Licence Resolution Request 19-014 for 1550 Johnston Road.

Page 201

8.2 PERMITS

None

9. CORRESPONDENCE

9.1 CORRESPONDENCE - RECEIVED FOR INFORMATION

***Note:** Further action on the following correspondence items may be considered. Council may request that any item be brought forward for discussion, and may propose a motion of action on the matter.*

9.1.1 Letter dated December 19, 2019 from B. Kish, Executive Director of the Peace Arch Hospice Society, thanking City Council for their financial donation of \$2,000 through the Holiday Home Tour for Hope **Page 205**

9.1.2 Letters from the Lower Mainland Local Government Association (LMLGA): **Page 206**

a) January 6, 2020 from LMLGA Past President Councillor Jason Lum calling for nominations to the 2020 LMLGA Executive

***Note:** The deadline to submit nominations is Friday, March 12, 2020. Details on the nomination process and qualifications for office are noted within the correspondence.*

- b) January 6, 2020 from LMLGA President Mayor Jack Crompton calling for resolutions at the 2020 Annual General Meeting

***Note:** The deadline to submit resolutions is Thursday, March 5, 2020. Details on how to submit a resolution are noted within the correspondence.*

10. MAYOR AND COUNCILLOR REPORTS

10.1 MAYOR'S REPORT

10.2 COUNCILLORS REPORTS

10.2.1 METRO VANCOUVER BOARD IN BRIEF

None

11. MOTIONS AND NOTICES OF MOTION

11.1 MOTIONS

None

11.2 NOTICES OF MOTION

None

12. RELEASE OF ITEMS FROM CLOSED COUNCIL MEETINGS

None

13. OTHER BUSINESS

14. CONCLUSION OF THE JANUARY 13, 2020 REGULAR COUNCIL MEETING

PRESENT: Mayor Walker
Councillor Chesney
Councillor Fathers
Councillor Johanson
Councillor Kristjanson
Councillor Manning
Councillor Trevelyan

STAFF: D. Bottrill, Chief Administrative Officer
T. Arthur, Director of Corporate Administration
J. Gordon, Director of Engineering and Municipal Operations
S. Kurylo, Director of Financial Services
E. Stepura, Director of Recreation and Culture
S. Lam, Deputy Corporate Officer

Press: 1
Public: 21

1. **CALL MEETING TO ORDER**
The meeting was called to order at 7:00 p.m.

2. **ADOPTION OF AGENDA**

2019-583 **It was MOVED and SECONDED**
THAT the Corporation of the City of White Rock Council adopts the agenda for its regular meeting scheduled for December 16, 2019 as circulated.

CARRIED

3. **ADOPTION OF MINUTES**
a) December 2, 2019 – Regular Council

2019-584 **It was MOVED and SECONDED**
THAT the Corporation of the City of White Rock Council adopts the following meeting minutes as circulated:

a) December 2, 2019 – Regular Council

CARRIED

3.1 **SPECIAL PRESENTATION**

4. **QUESTION AND ANSWER PERIOD**

Question and Answer period is an opportunity for the public to ask questions and make comments. There will be a Speaker's List available, each speaker will be given two (2) minutes and one (1) opportunity to ask a question(s) or make a comment. Question period shall be 15 minutes. Question and Answer Period is noted in the record and once

the minutes are adopted, the questions and answers will be available on the [Question and Answer Period webpage](#).

4.1 CHAIRPERSON CALLS FOR SPEAKERS TO QUESTION AND ANSWER PERIOD

- G. Wolgemuth, White Rock, commented on the topic of the *Community Charter* section 131 that came forward in July to reconsider a motion in regard to the Plaza at Lions Lookout Park, He stated that he found the way this matter has been handled to be disrespectful and that it has been a waste of time.
- K. Jones, White Rock, informed that following the December 2, 2019 Council meeting he let the Director of Engineering and Municipal Operations know that a light standard was not functioning and is pleased to congratulate Mr. Gordon and his staff as it was repaired within the week.

5. DELEGATIONS AND PETITIONS

5.1 DELEGATIONS

5.1.1 HALENA SEIFERLING: LIVING WAGE FOR FAMILIES CAMPAIGN

H. Seiferling, Campaign Organizer, Living Wage for Families Campaign, appeared as a delegation to inform on the living wage for families campaign.

2019-585

It was MOVED and SECONDED

THAT Council directs staff to bring forward a corporate report regarding the potential of implementing a living wage for families concept and the financial impact it could have for the City.

CARRIED

5.1.2 GAYLE SAUNDERS: WHITE ROCK LAWN BOWLING CLUB

G. Saunders, White Rock Lawn Bowling Club, appeared as a delegation requesting approval of a loan / funding in the amount of \$62,000 to replace the worn-out playing surface on the City owned property.

2019-586

It was MOVED and SECONDED

THAT Council directs staff to bring forward a corporate report in regard to the request by Gayle Saunders with the White Rock Lawn Bowling Club for support in regard to a loan for funding in the amount of \$62,000 to enable them to replace the worn-out playing surface on the City owned property.

CARRIED

5.2 PETITIONS

None

6. PRESENTATIONS AND CORPORATE REPORTS

6.1 **PRESENTATIONS**

None

6.2 **CORPORATE REPORTS**

6.2.1 **PROPOSED WHITE ROCK BUSINESS IMPROVEMENT AREA – PETITION PROCESS**

Corporate report dated December 16, 2019 from the Director of Corporate Administration titled “Proposed White Rock Business Improvement Area – Petition Process”.

2019-587 **It was MOVED and SECONDED**

THAT Council receives for information the corporate report dated December 9, 2019 from the Director of Corporate Administration titled “Proposed White Rock Business Improvement Area – Petition Process”.

CARRIED

6.2.2 **GRAND CHIEF BERNARD ROBERT CHARLES PLAZA AND LIONS LOOKOUT PARK**

Corporate report dated December 16, 2019 from the Chief Administrative Officer Administration titled “Grand Chief Bernard Robert Charles Plaza and Lions Lookout Park”.

2019-587 **It was MOVED and SECONDED**

THAT Council:

1. Receives for information the corporate report dated December 16, 2019, from the Director of Corporate Administration, titled “Grand Chief Bernard Robert Charles Memorial Plaza and Lions Lookout Park”; and
2. Endorses and confirm that the name of the plaza within Lions Lookout Park is “Grand Chief Bernard Robert Charles Memorial Plaza”.

CARRIED

Note: It was noted that staff need to ensure that no further reference to “Totem Park” is made within City information.

Subsequent Motion:

2019-588 **It was MOVED and SECONDED**

THAT Council endorses the City enter into discussion(s) with the Semiahmoo First Nation to explore the possibility of naming Lions Lookout Park as the Grand Chief Bernard Robert Charles Park.

CARRIED

Mayor Walker voted in the negative

7. **MINUTES AND RECOMMENDATIONS OF COMMITTEES**

7.1 **STANDING AND SELECT COMMITTEE MINUTES**

- Land Use and Planning Committee – December 2, 2019
- Parking Task Force – November 14, 2019
- Marine Drive Task Force – November 19, 2019
- Housing Advisory Committee – November 25, 2019
- Tour de White Rock Committee – November 28, 2019

2019-589

It was MOVED and SECONDED

THAT Council receives for information the following standing and select committee meeting minutes as circulated:

Land Use and Planning Committee – December 2, 2019;

- a) Parking Task Force – November 14, 2019;
- b) Marine Drive Task Force – November 19, 2019;
- c) Housing Advisory Committee – November 25, 2019
- d) Tour de White Rock Committee – November 28, 2019.

CARRIED

7.2 **STANDING AND SELECT COMMITTEE RECOMMENDATIONS**

- a) The following recommendations have been brought forward from the **Parking Task Force** meeting held on November 14, 2019:

2019-590

It was MOVED and SECONDED

THAT Council directs staff to provide a corporate report regarding the feasibility of a business staff parking program, for businesses along Marine Drive, in the newly created waterfront parkade and the Montecito parking locations and that this report be provided back to the Parking Task Force for their information/discussion.

CARRIED

Councillor Fathers voted in the negative

2019-591

It was MOVED and SECONDED

THAT Council endorses additional signage for parking hours and rates on the waterfront.

CARRIED

Councillors Chesney, Johanson and Fathers voted in the negative

2019-592

It was MOVED and SECONDED

THAT Council endorses increasing parking violation fines to \$70 for full payment, and \$35 for early payment from the current \$60 for full payment, and \$30 for early payment.

DEFEATED UNANIMOUSLY

Note: It was stated that this recommendation does not coincide with the direction of Council who previously discussed a different rate pattern.

- 2019-593 **It was MOVED and SECONDED**
THAT Council endorses extending the term for the Task Force until December 31, 2020, meeting on a quarterly basis in order to follow-up on the work that the Task Force has done.
DEFEATED
Councillors Chesney, Fathers, Kristjanson and Manning voted in the negative
- 2019-594 **It was MOVED and SECONDED**
THAT Council directs staff to review the parking setback(s) at the corner of Marine Drive and Parker Street, and take action as appropriate.
CARRIED
Councillors Chesney and Fathers voted in the negative
- b) The following recommendations have been brought forward from the **Marine Drive Task Force** meeting held on November 19, 2019:
- 2019-595 **It was MOVED and SECONDED**
THAT the Council receives the following information from the Marine Drive Task Force with respect to servicing agreements between the City and Semiahmoo First Nation:

THAT the Marine Drive Task Force supports Council's ongoing discussion with the Semiahmoo First Nation regarding Municipal Service Agreements, and sees them as an integral part of the revitalization of Marine Drive.
CARRIED
Councillor Kristjanson voted in the negative
- 2019-596 **It was MOVED and SECONDED**
THAT Council receives the request for consideration from the Marine Drive Task Force with respect to exploring ways to increase funding to the White Rock Museum and Archives to support environment, Semiahmoo First Nation, and Semiahmoo Peninsula history and cultural educational programming.
CARRIED
Councillor Kristjanson voted in the negative
- 2019-597 **It was MOVED and SECONDED**
THAT Council requests a corporate report be brought forward with a request for funds for signage (in English and Sencoten) to support Semiahmoo First Nation storytelling and wayfinding on the waterfront, included within the report will be information as to whether Community Amenity Contributions (CAC's) can be utilized for this type of use.
CARRIED

- c) The following recommendations have been brought forward from the **Tour de White Rock Committee** meeting held on November 28, 2019:

2019-598

It was MOVED and SECONDED

THAT Council directs staff to proceed with hiring a contractor to train and certify community volunteers to work as traffic control personnel for the Tour de White Rock and other City events.

CARRIED

8. BYLAWS AND PERMITS

8.1 BYLAWS

8.1.1 BYLAW 2311 - WHITE ROCK BUSINESS IMPROVEMENT AREA (BIA) BYLAW 2019, NO. 2311

Bylaw No. 2311 proposes to renew the Business Improvement Area Bylaw, and an approximate 2% increase to the BIA levy. This Bylaw was given first, second and third reading on October 7, 2019. In accordance with the *Community Charter* on October 18, 2019 notice of intention concerning the proposed bylaw was sent to all owners of Class 06 (Business and Other) properties within the area shown on Schedule A of the bylaw (the "Area"). Ads were also placed in the 23rd and 30th, 2019 editions of the Peace Arch News. The deadline for receipt of petitions against the proposed bylaw was November 29, 2019. The *Community Charter* provides that Council may proceed with establishing the business improvement area (BIA Bylaw) unless a sufficient petition process against the service is presented within 30 days after publication of the newspaper notice. Due to the petition against the local area service (business improvement area) is insufficient Council may proceed with consideration of the adoption of Bylaw No. 2311.

2019-599

It was MOVED and SECONDED

THAT Council gives final reading to "*White Rock Business Improvement Area Bylaw, 2019, No. 2311*".

CARRIED

Councillor Chesney voted in the negative

8.1.2 BYLAW 2321 - WATER SERVICES BYLAW, 2015, NO. 2117, AMENDMENT NO. 7, BYLAW, 2019, NO. 2321

Bylaw 2321 proposes to establish the City's Water Utility Fees for 2020. This bylaw received three readings at the December 2, 2019 Regular meeting, and is presented for consideration of final reading.

2019-599

It was MOVED and SECONDED

THAT Council gives final reading to "*Water Services Bylaw, 2015, No. 2117, Amendment No. 7, Bylaw, 2019, No. 2321*".

CARRIED

8.2 **PERMITS**
None

9. **CORRESPONDENCE**

9.1 **CORRESPONDENCE - RECEIVED FOR INFORMATION**

Note: *Further action on the following correspondence items may be considered. Council may request that any item be brought forward for discussion, and may propose a motion of action on the matter.*

Note: *Council Policy No. 109 notes that the City of White Rock does not make official proclamations. Item 8.1.1 has been included under correspondence for public information purposes only.*

2019-600 **It was MOVED and SECONDED**

THAT Council receives for information the following correspondence Items 9.1.1 – 9.1.2 as circulated in the agenda:

9.1.1 Email dated December 4, 2019 from Dorothy Gurney, BC Coordinating Council of Public Affairs for the Church of Jesus Christ of Latter-day Saints, requesting February 1-7, 2020 be proclaimed as the United Nations World Inter-Faith Harmony Week; and

9.1.2 Email dated December 11, 2019 from the BC Achievement Foundation requesting Nominations for the 17th Annual Community Award.

CARRIED

CORRESPONDENCE CONSIDERED FOR ACTION:

9.1.3 Letter dated November 4, 2019 from C. Plagnol, Metro Vancouver Corporate Officer, requesting consideration of participating area approval/consent with respect to Metro Vancouver Regional Parks Service Amendment Bylaw, No. 1290

2019-601 **It was MOVED and SECONDED**

THAT Council consents to the approval of the adoption of *Metro Vancouver Regional District Regional Parks Service Amending Bylaw, No. 1290, 2019* on behalf of the electors; and directs staff to notify the Metro Vancouver Regional District Board of its consent.

CARRIED

Councillors Kristjanson and Trevelyan voted in the negative

Note: The Director of Planning and Development Services gave a brief summary on the information provided.

- 9.1.4** Letter dated November 28, 2019 from Sav Dhaliwal, Metro Vancouver Board Chairperson, inviting the City to provide comments with respect to the proposed amendment to “*Metro Vancouver 2040: Shaping our Future to Align with the IPCC Special Report on Global Warming of 1.5 degrees Celsius – Bylaw No. 1295, 2019*”.

2019-602

It was MOVED and SECONDED

THAT the Council refers the matter to staff for a corporate report at the January 13, 2020 regular Council meeting regarding the letter dated November 28, 2019 from Metro Vancouver’s Board Chairperson, inviting the City to provide comments with respect to the proposed amendment to “*Metro Vancouver 2040: Shaping our Future to Align with the IPCC Special Report on Global Warming of 1.5 degrees Celsius – Bylaw No. 1295, 2019*.”

CARRIED

10. MAYOR AND COUNCILLOR REPORTS

10.1 MAYOR’S REPORT

Mayor Walker noted the following community events and information:

- Dec 3, RCMP Lower Mainland District’s Mayor’s Forum
- Dec 3, Council to Council meeting with the Semiahmoo First Nation
- Dec 4, Coldest Night of the Year 2020 Kick Off Breakfast
- Dec 5, Kent Street Mistletoe Lunch
- Dec 5, Salvation Army’s Community Adult’s and Seniors’ Christmas Dinner
- Dec 5, Grand Opening of Chez Christophe
- Dec 7, Jiggle Bell White Rock Christmas Event and the Opening of the White Rock Festival of Lights
- Dec 7, White Rock Community Orchestra “The Spirit of Yuletide”
- Dec 8, Global TV interview “Friends of the Pier”
- Dec 8, "Friends of the Pier" Certificate Presentation for "Planks for the Pier" Purchasers
- Dec 9, Finance and Audit Committee meeting
- Dec 10, Friends of the Ocean Promenade Hotel’s Christmas Reception
- Dec 11, Governance and Legislation Committee meeting (RCMP Integration Team Presentation)
- Dec 11, Chef’s for the Pier fundraising event
- Dec 12, TranksLink Mayor’s Council on Regional Transportation
- Dec 12, Finance and Audit Committee meeting

10.2 COUNCILLORS REPORTS

Councillor Kristjanson noted the following community events and information:

- Dec 4, Coldest Night of the Year 2020 Kick Off
- Dec 7, Let's Talk Community Conversation
- Dec 8, "Friends of the Pier" Certificate Presentation for "Planks for the Pier" Purchasers
- Dec 12, Picked up dog debris on the Promenade

Councillor Fathers noted the following community events and information:

- Dec 3, Council to Council meeting with the Semiahmoo First Nation
- Dec 5, Kent Street Mistletoe Lunch
- Dec 7, Jiggle Bell White Rock Christmas event
- Dec 7, "Scrooge" Play
- Dec 9, Finance and Audit Committee meeting
- Dec 10, Friends of the Ocean Promenade Hotel's Christmas reception
- Dec 11, Governance and Legislation Committee meeting (RCMP Integration Team Presentation)
- Dec 12, Finance and Audit Committee meeting

Councillor Trevelyan noted the following community events and information:

- Dec 3, Council to Council meeting with the Semiahmoo First Nation
- Democracy Direct Annual General Meeting
- Business Improvement Association (BIA) event
- Dec 5, Grand Opening of Chez Christophe
- Dec 5, Salvation Army's Community Adult's and Seniors' Christmas dinner
- Dec 7, Jiggle Bell White Rock Christmas event and the Opening of the White Rock Festival of Lights
- Dec 7, White Rock Fire Fighters Association's 24th Annual Breakfast with Santa
- Dec 8, "Friends of the Pier" Certificate Presentation for "Planks for the Pier" Purchasers
- Dec 9, Finance and Audit Committee meeting
- Dec 10, Friends of the Ocean Promenade Hotel's Christmas reception
- Dec 10, Open House of Tracy Redies, MLA for Surrey-White Rock and Marvin Hunt, MLA for Surrey / Cloverdale
- Dec 11, Governance and Legislation Committee meeting (RCMP Integration Team Presentation)
- Dec 12, Finance and Audit Committee meeting
- Dec 14, Annual CARP Christmas Event

Councillor Manning noted the following community events and information:

- Dec 3, Council to Council meeting with the Semiahmoo First Nation
- Dec 3, Business Improvement Association (BIA) Christmas event
- Democracy Direct Annual General Meeting
- Dec 7, White Rock Fire Fighters Association's 24th Annual Breakfast with Santa
- Dec 12, Applicant's presentation for 1485 Fir Street
- Dec 14, Annual CARP Christmas event

Future Information: The City may be hosting its own Walk for Veterans in September 2020

Councillor Johanson noted the following community events and information:

- Dec 3, Council to Council meeting with the Semiahmoo First Nation
- Dec 5, Kent Street Mistletoe Lunch
- Dec 5, Environmental Advisory meeting
- Dec 7, Let's Talk Community Conversation
- Dec 7, Jiggle Bell White Rock Christmas event, Sail Past and the Opening of the White Rock Festival of Lights
- Dec 9, Finance and Audit Committee meeting
- Dec 10, Friends of the Ocean Promenade Hotel's Christmas reception
- Dec 11, Governance and Legislation Committee meeting (RCMP Integration Team Presentation)
- Dec 12, Finance and Audit Committee meeting
- Dec 14, Annual CARP Christmas event

Councillor Chesney noted he had nothing further to add to what has been noted previously.

10.2.1 **METRO VANCOUVER BOARD IN BRIEF**

METRO VANCOUVER BOARD IN BRIEF – NOVEMBER 29, 2019

2019-603

It was MOVED and SECONDED

THAT Council receives for information the November 29, 2019 Metro Vancouver Board in Brief document.

CARRIED

11. **MOTIONS AND NOTICES OF MOTION**

11.1 **MOTIONS**

COUNCILLORS MANNING AND KRISTJANSON: PROPOSED BYLAW TO PROTECT RENTERS FROM DEMO-VICTIONS

Councillors Manning and Kristjanson brought forward the following topic for consideration. An article dated December 3, 2019 titled “Burnaby adopts *Best in Canada* tenant assistance policy” is attached for reference purposes.

2019-604 **It was MOVED and SECONDED**

THAT Council directs staff to bring forward a bylaw that ensures residents are treated fairly and provided with rent protection, moving expenses, and the right of first refusal to rent similar rental units with the same price prior to the renoviction.

DEFEATED

Councillors Chesney, Fathers, Manning, Trevelyan voted in the negative

Subsequent Motion

2019-605 **It was MOVED and SECONDED**

THAT Council directs staff to bring forward a corporate report regarding City Policies 514 and 516 with a complete comparison of information to those adopted by other municipalities such as the City of Port Coquitlam and the City of Burnaby and outline any possible “gaps” in the City’s noted policies that others may include and, could work for the City of White Rock, to help strengthen Policies 514 and 516.

CARRIED

11.2 **NOTICES OF MOTION**

None

12. **RELEASE OF ITEMS FROM CLOSED COUNCIL MEETINGS**

None

13. **OTHER BUSINESS**

14. **CONCLUSION OF THE DECEMBER 16, 2019 REGULAR COUNCIL MEETING**

The Chairperson declared the meeting concluded at 9:13 p.m.

Mayor Walker



Tracey Arthur, Director of
Corporate Administration

THE CORPORATION OF THE
CITY OF WHITE ROCK
CORPORATE REPORT

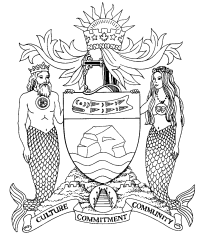

DATE: January 13, 2020
TO: Mayor and Council
FROM: Jacquie Johnstone, Director, Human Resources
SUBJECT: CAO Recruitment Executive Search Firm Contract Award

RECOMMENDATIONS

THAT Council:

1. Receive for information the corporate report dated January 13 2020 from the Director of Human Resources titled “CAO Recruitment Executive Search Firm Contract Award; and
 2. Authorize staff to award a contract for a CAO recruitment outreach services to the executive search firm Waterhouse Executive Search at a professional fee of \$18,500.
-

INTRODUCTION

At the December 2, 2019 Regular Council Meeting, Council passed a motion (2019-557) to identify a suitable executive search firm to provide outreach services for the Chief Administrative Officer recruitment. The purpose of this report is to seek Council’s authorization to award a contract to Waterhouse Executive Search

PAST PRACTICE / POLICY / LEGISLATION

The award of contracts is governed by Council Policy #301. Although this policy does not require Council’s approval to award this contract at the quoted fees, the selected executive search firm will be providing direct assistance to Council in its search for a new CAO.

ANALYSIS

On December 4, 2019, five local executive search firms were invited to quote on an executive recruitment for the CAO position with a closing date of December 16, 2019. Proposals were received from Employment Office and Scout Talent, Harbour West Consulting, Odgers Berndtson, PFM Executive Search and Waterhouse Executive Search. The proposals were rated on the following:

- Relevant Search Experience
- Recruitment and Support Process
- Ability to Source Top Candidates
- Reputation and Track Record
- Cost
- Successful Placement Guarantee
- Timeframe for Commencement/Completion of Process

All but two firms met most of the criteria; one was eliminated as they scored relatively low compared to the other four firms, and one was eliminated because they were not prepared to offer a service restricted to outreach and shortlist and at a significantly higher cost.

On the whole, exclusive of cost, the remaining three firms were close in criteria ranking, with the exception of one who ranked lower in relevant experience, given they had no experience hiring a CAO position within local government. Waterhouse Executive Search's professional fee is approximately 50% less than the others. Second in ranking was Odgers Berndtson who ranked very close to Waterhouse in all criteria, except for the professional fee. All three firms confirmed that additional fees such as advertising and candidate travel expenses would be in addition to the professional fee. The contract awarded will include terms to control the costs of such additional fees.

BUDGET IMPLICATIONS

A one-time amount of \$45,000 is included in the 2020 Financial Plan funded from an operating reserve or the City's accumulated surplus to pay for all costs associated with the CAO recruitment.

CONCLUSION

Council has opted to engage an executive search firm to assist the recruitment of the City's CAO position. Proposals from five firms were ranked by Human Resources with a recommendation to award the contract to Waterhouse Executive Search.

Respectfully submitted,



Jacquie Johnstone
Director, Human Resources

Comments from the Chief Administrative Officer:

I concur with the recommendations of this corporate report.



Dan Bottrill
Chief Administrative Officer

THE CORPORATION OF THE
CITY OF WHITE ROCK
CORPORATE REPORT

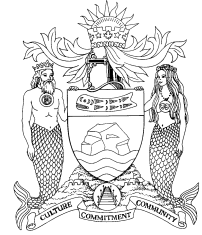

DATE: January 13, 2020
TO: Mayor and Council
FROM: Dr. Saad Jasim, P.Eng., Manager, Utilities
SUBJECT: Patent Submission for the White Rock Water Treatment Plant

RECOMMENDATIONS

THAT Council:

1. Receive for information the corporate report dated January 13, 2020, from the Manager, Utilities titled "Patent Submission for the White Rock Water Treatment Plant"; and
 2. Approve the request to proceed with the submission of a Patent for the Water Treatment Plant.
-

INTRODUCTION

A patent is a legal title protecting an invention. For a technology or a system to be patented, the product or process must include a novel approach, involve an inventive step and be susceptible of industrial application. Patents grant their owner a set of rights of exclusivity over an invention. The legal protection conferred by a patent gives its owner the right to exclude others from making, using, selling, offering for sale or importing the patented invention for the term of the patent, which is usually 20 years from the filing date, and in the country or countries where the patent has been filed (and subsequently granted). This set of rights provides the patentee with a competitive advantage.

The value of individual patents has an importance due to the significance in its application. Many patents have very low value, the distribution is skewed, due to the lack of potential application in the industry.

The economic benefits of the patent system are derived from its roles in promoting innovation, and encouraging investment, economic growth, knowledge sharing and the efficient use of resources. In addition, possessing a patent may help the organization to grow by capitalizing on the market potential of its inventions.

The City of White Rock Water Treatment Plant was designed and built based on the research finding conducted at the City of White Rock in collaboration with the Reseau-WaterNet, which was introduced to the proponents for the Design Build Project. The system included specific sequence of applications that were not present in the literature surveyed.

A detailed discussion took place between Dr. Saad Jasim, Manager, Utilities, Dr. Madjid Mohseni, Scientific Director, Reseau-WaterNet, Professor at UBC, and Rob Bruent, Patent Attorney, Brunet & Co., regarding the process, its novelty and significance to the health of the

community and to the water industry were highlighted. Mr. Bruent indicated that there is a good potential for the application to be patented.

Options were discussed regarding the cost for the submission of the application. The fee for submission, and cost of filing is between \$10,000-\$12,000 (as quoted in May 2019). When the patent is filed, potential additional cost for applications and communication is around \$30,000 over 5 years.

PAST PRACTICE / POLICY / LEGISLATION

The cost of filing a patent for the inventor is mandatory for public disclosure of the description of the technology, which makes following the design easier and facilitates future technological developments.

ANALYSIS

The economic benefits of the patent system are derived from its roles in promoting innovation, and encouraging investment, economic growth, knowledge sharing and the efficient use of resources. In addition, possessing a patent may help the organization to grow by capitalizing on the market potential of its inventions. Patents impact on economic growth of regional and national industry would happen due to potential investments from governments, local, regional and national industries to develop and expand the application of such patents. Profits generated by patent exploitation can be invested in further research and development in infrastructure, employment, which may stimulate commercial and industrial growth.

The findings in this patent application would provide significant savings on capital and operational cost to new applicants of this process.

BUDGET IMPLICATIONS

A budget of approximately \$15,000 (\$12,000 was the cost indicated by the lawyer in May 2019) is required for the cost of filling the Patent. Future cost when the patent is in the market is expected to be approximately \$30,000 over 5 years.

RISK MANAGEMENT

The delay in submitting the Patent Application could cause obstacles due to the available information.

CONCLUSION

The submission of a patent for the design of the White Rock Water Treatment Plant would benefit the City of White Rock financially and provide a higher profile for the performance and development at the City of White Rock. The recommendation is to approve the award of \$15,000 to Brunet & Co. for the Patent submission, and budget \$30,000 cost over 5 years.

Respectfully submitted,



Dr. Saad Jasim, P.Eng.
Manager, Utilities

Comments from the Chief Administrative Officer:

This corporate report was prepared in response to a resolution of Council to review the possibility of obtaining a patent for the water treatment system.

It is very rare that I have a contrary view to City staff. However, this is one of those occasions. To spend \$15,000 to apply for a patent and then a further \$30,000 over the next five years as described in this report would not serve to benefit the City of White Rock. I believe this would be a sunk cost with very little potential for any cost recovery or return on investment. It has been my experience that local governments in British Columbia and across Canada as well as North America freely share their best practice experiences, programs, processes, policies, and bylaws to the betterment of all taxpayers. This is a practice that should continue to be supported.

What is the objective of the Patent Application? The corporate report provides the following answers, which I will provide my comments:

1. The economic benefits of the patent system are derived from its roles in promoting innovation, and encouraging investment, economic growth, knowledge sharing and the efficient use of resources.

Local governments are continually working to improve processes. Knowledge sharing between local governments occurs regularly at the regional level and by attending conferences at the national and international level.

2. In addition, possessing a patent may help the organization to grow by capitalizing on the market potential of its inventions.

It is my understanding that this "invention" is more of a combination of the proven process of using Ozone for oxidization and the process of using AdEdge Technologies E33 filter media for Arsenic reduction in drinking water. Potentially, there could be other jurisdictions combining these two well established processes for the same purpose. It is unclear in this corporate report how the City of White Rock will grow from the Patent Application.

3. Patents impact on economic growth of regional and national industry would happen due to potential investments from governments, local, regional and national industries to develop and expand the application of such patents.

It is comforting to think that our Patent Application could lead to further economic growth at the regional and national level. However, I remain doubtful that this would occur as a result of our Patent Application. Further, I fail to understand how this benefits the City of White Rock and our taxpayers.

4. Profits generated by patent exploitation can be invested in further research and development in infrastructure, employment, which may stimulate commercial and industrial growth.

I remain doubtful that our Patent Application will generate a cost recovery for the cost of the patent and associated costs over the next five years as outlined in this corporate report. This corporate report does not provide a business case on how the City would benefit or achieve results from granting licences or obtaining royalties to use our design process. Imposing our right to such revenue may come at the cost of legal litigation that would require proving that another entity used our specific design process. Further, I do not believe it would necessarily be in the interests of the taxpayer to launch legal action for patent infringement by any local government who wishes to use our particular design process with the hopes of trying to obtain some revenues from granting licences or

royalties. Again, no business case to evaluate the level of revenues against the costs that are being requested.

5. The findings in this patent application would provide significant savings on capital and operational cost to new applicants of this process.

It is true that any organization (including academics) would benefit from the knowledge of this process. This is one reason why the City hosted students from the British Columbia Institute of Technology last year. However, the City would be able to accomplish this objective by speaking at conferences or submitting papers for publication regarding our design processes to the various utility associations such as the Canadian Water and Wastewater Association.

Unlike the private sector, the City does not need to have a patent to be used as a competitive advantage over others. We simply do not compete against other cities (with the exception of talented employees).

I am not supportive of applying for a patent. However, should the City ultimately take the position to pursue a Patent Application, I would assume that we would do so as cost sharing partners with the University of British Columbia as they were participants in the pilot project which was referenced by NAC Constructors in their Design Build proposal that the City accepted for the Water Treatment Plant.



Dan Bottrill
Chief Administrative Officer

THE CORPORATION OF THE
CITY OF WHITE ROCK
CORPORATE REPORT

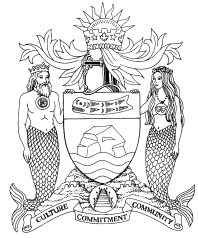

DATE: January 13, 2020

TO: Mayor and Council

FROM: Carl Isaak, Director of Planning and Development Services

SUBJECT: Response to *Metro Vancouver 2040: Shaping our Future Greenhouse Gas Emission Targets Amendment Request*

RECOMMENDATIONS

THAT Council:

1. Receive for information the corporate report dated January 13, 2020 from the Director of Planning and Development Services titled “Response to *Metro Vancouver 2040: Shaping our Future Greenhouse Gas Emission Targets Amendment Request*,” and
 2. Authorize the Director of Corporate Administration to respond to the Metro Vancouver Board stating that the City does not object to the proposed amendment to the Regional Growth Strategy, and by sending Council commentary and any applicable resolution along with this corporate report as a response to the Metro Vancouver Board request for comment.
-

BACKGROUND

The purpose of this report is to notify Mayor and Council of a proposed amendment to the Regional Growth Strategy (RGS), and to provide Council with an opportunity to comment on the proposed amendment. The Metro Vancouver Regional District (MVRD) Board has initiated a change to the greenhouse gas (GHG) emissions reduction targets in the RGS to reflect a commitment to align with the targets in the October 2018 Intergovernmental Panel on Climate Change (IPCC) Special Report on Global Warming.

A letter from the Chair of the MVRD Board to Mayor and Council providing an opportunity to provide written comment on the proposed amendment was received by the City on November 28, 2019 and at the Regular Council meeting on December 16, 2019, the letter was referred to staff to provide a corporate report on the proposed amendment.

The proposed change to the GHG emissions reduction targets are a ‘Type 3’ minor amendment to the RGS, requiring a 50%+1 weighted vote of the Metro Vancouver Board in favour of the amendment, and no regional public hearing is required. First, second and third readings of the MVRD amendment bylaw were given on November 1, 2019, and MVRD staff were directed to notify local governments to obtain input. Following consideration of written comments from local governments and other agencies (up to January 17, 2020), the MVRD Board will consider final adoption of the bylaw.

To provide further detail on the proposed amendment, the letter from Metro Vancouver inviting comment from local governments, and the MVRD corporate report to the Regional Planning Committee are attached as Appendices A and B, respectively, for Council’s information.

ANALYSIS

White Rock Implications

Policy 12.5.1 of the Official Community Plan (OCP) identifies the current GHG reduction targets in place for the City of White Rock.

Policy 12.5.1 Greenhouse Gas Emissions Reduction Targets – Undertake a study to establish updated greenhouse gas emissions targets, including city-wide targets as well as targets for buildings, transportation, and solid waste. Until such targets are updated, reduce greenhouse gas emissions in accordance with the recommendations of the City of White Rock Community Climate Action Plan:

- a. 10% below 2007 levels by 2020; and*
- b. 50% below 2007 levels by 2050.*

No immediate update to the City’s GHG emissions reduction targets or to the City’s Regional Context Statement would be required as a result of the proposed amendment to the RGS. Future amendments to the OCP or to a Community Energy and Emissions Plan (i.e. an update to the Community Climate Action Plan) would be opportunities to consider aligning City targets and actions with the regional targets.

While the GHG reduction targets in the Metro 2040 RGS are currently proposed to be amended to align with the IPCC targets, the comprehensive update to the RGS which is currently underway (“Metro 2050”) will also have an emphasis on climate change and will likely identify other recommended actions for meeting these targets.

It would be practical to update the City’s GHG reduction targets and actions following the comprehensive update to the RGS, at which time the City’s Regional Context Statement would require review or updating for consistency with the policies and recommended actions in the new RGS. In the interim, the existing policies regarding conserving energy and reducing greenhouse gas emissions in the OCP such as moving forward with adopting the BC Energy Step Code and requiring electric vehicle charging stations in new developments, will continue to be implemented.

Regional Planning Implications

Climate 2050 is Metro Vancouver’s long-term strategy for transitioning to a carbon neutral and climate resilient region. In July 2019, the MVRD Board amended the GHG emissions reduction targets within *Climate 2050* from 80% below 2007 levels by 2050 to carbon neutral by 2050 (and 45% below 2010 levels by 2030). This change to *Climate 2050* was accompanied by a direction to MVRD staff to similarly change the GHG emissions reduction targets in the *Metro 2040: Shaping our Future* RGS. Due to the requirements to notify local governments and obtain an affirmative vote of the MVRD Board prior to amending the RGS, the letter attached to this corporate report is being provided to allow written comment in the form of a resolution for the MVRD Board to consider prior to voting on third reading and final adoption of the amendment.

Staff Commentary

Staff do not anticipate direct impacts to the City of White Rock from the proposed amendment and staff have no objection to this proposed amendment. Future amendments to the City’s OCP and Regional Context Statement will need to consider the revised regional GHG emissions reduction targets and locally appropriate targets and actions to contribute to achieving the regional goals. Staff recommend this corporate report, along with Council comments and any

applicable resolution be sent to Metro Vancouver Board as a response to their request for comments.

OPTIONS

Option 1: Authorize the Director of Corporate Administration to respond to the Metro Vancouver Board stating the City has no objection to the proposed amendment to the RGS by sending Council commentary and any applicable resolution along with this corporate report as a response to the Metro Vancouver Board request for comment; or

Option 2: Direct staff to provide another response to Metro Vancouver.

Staff recommend Option 1, which is reflected in the recommendations of this report.

CONCLUSION

Metro Vancouver (MVRD) is seeking comment on a proposed amendment to the Regional Growth Strategy (RGS) regarding a reduction to the regional greenhouse gas (GHG) emissions reduction targets from 80% below 2007 levels by 2050 to carbon neutral by 2050 and 45% below 2010 levels by 2030. This change to the RGS targets is intended to align with the targets in the October 2018 Intergovernmental Panel on Climate Change (IPCC) Special Report on Global Warming, which have already been incorporated into MVRD's *Climate 2050* long-term strategy for transitioning to a carbon neutral and climate resilient region. The requested Type 3 amendment to the RGS is not expected to immediately affect the City's interests and staff have no objection to the proposed RGS amendment. Future amendments to the City's OCP and Regional Context Statement will need to consider the revised regional GHG emissions reduction targets and locally appropriate targets and actions to contribute to achieving the regional goals. Staff recommend that Council authorize the Director of Corporate Administration to respond to the Metro Vancouver Board by sending Council commentary and any applicable resolution along with this corporate report as a response to the Metro Vancouver Board request for comment.

Respectfully submitted,



Carl Isaak, MCIP, RPP
Director of Planning and Development Services

Comments from the Chief Administrative Officer:

I concur with the recommendations of this report.

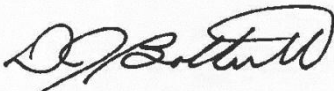

Dan Bottrill
Chief Administrative Officer

Appendix A: Letter from Metro Vancouver received November 28, 2019

Appendix B: MVRD Report to Regional Planning Committee titled "Amending *Metro Vancouver 2040: Shaping our Future* to Align with the IPCC Special Report on Global Warming of 1.5°C – Bylaw 1293, 2019

APPENDIX A

Letter from Metro Vancouver received November 28, 2019



Office of the Chair
Tel. 604 432-6215 Fax 604 451-6614

File: CR-12-01
Ref: RD 2019 Nov 1

NOV 28 2019

Mayor Darryl Walker and Council
City of White Rock
15322 Buena Vista Avenue
White Rock, BC V4B 1Y6

Dear Mayor Walker and Council:

Re: Amending Metro Vancouver 2040: Shaping our Future to Align with the IPCC Special Report on Global Warming of 1.5°C – Bylaw No. 1295, 2019

At its November 1, 2019 regular meeting, the Board of Directors of the Metro Vancouver Regional District (Metro Vancouver) adopted the following resolution:

That the MVRD Board:

- a) *initiate a Type 3 minor amendment to Metro Vancouver 2040: Shaping our Future to reflect a commitment to a carbon neutral region by 2050, and an interim target of reducing greenhouse gas emissions by 45% from 2010 levels by 2030;*
- b) *give first, second, and third readings to “Metro Vancouver Regional District Regional Growth Strategy Amendment Bylaw No. 1295, 2019”; and*
- c) *direct staff to notify affected local governments and agencies as per Section 6.4.2 of Metro Vancouver 2040: Shaping our Future.*

In accordance with Section 437 of the *Local Government Act*, and Section 6.4.2 of *Metro Vancouver 2040: Shaping our Future (Metro 2040)*, the regional growth strategy, this letter provides an opportunity for affected local governments to provide written comment on the proposed Type 3 minor amendment to *Metro 2040*. The proposed amendment requires the adoption of an amendment bylaw with an affirmative 50%+1 weighted vote of the MVRD Board.

You are invited to provide comments on the proposed amendment to *Metro 2040*. Please provide comments in the form of a Council or Board resolution, as applicable, and submit to Chris Plagnol, Corporate Officer/Director of Board and Information Services, by email at Chris.Plagnol@metrovancover.org by January 17, 2020.

33385170

The proposed *Regional Growth Strategy Amendment Bylaw No. 1295, 2019* would replace the existing greenhouse gas emission reduction targets in *Metro 2040* in accordance with the table below:

Current GHG Reduction Targets in <i>Metro 2040</i>	Proposed GHG Reduction Targets (Aligned with <i>Climate 2050 Strategic Framework</i> and the <i>IPCC 2019 Special Report</i>)
<ul style="list-style-type: none">• 33% below 2007 levels by 2020• 80% below 2007 levels by 2050	<ul style="list-style-type: none">• 45% reduction from 2010 levels by 2030• Carbon neutral by 2050

Updating the targets in *Metro 2040* is consistent with recent MVRD Board direction, the 2019-2022 Board Strategic Plan and the *Climate 2050 Strategic Framework*.

Metro 2040 represents the regional federation's collective vision and commitment on how to manage anticipated growth to the region in a way that: supports the development of complete, connected and resilient communities, protects important lands (i.e. agricultural, conservation, and industrial), and supports the efficient provision of urban infrastructure (i.e. transit and utilities). Centred around 5 goals, *Metro 2040* contains a set of policy actions for Metro Vancouver and member jurisdictions to collaboratively work together to meet that vision.

Under Strategy 3.3, 'Encourage land use and transportation infrastructure that reduce energy consumption and greenhouse gas emissions, and improve air quality', the role of member jurisdictions is to adopt regional context statements that identify how they will use their land development and transportation strategies to meet their greenhouse gas reduction targets and consider how these targets will contribute to the regional targets.

The proposed Metro 2040 amendment would not trigger a requirement to immediately update regional context statements, however, if the amendment bylaw is adopted, member jurisdictions would be requested to update their regional context statements to reflect actions toward the updated targets as feasible, either concurrent with updates to their Official Community Plans, Community Energy and Emissions Plans, or other strategic planning documents. Meeting the regional commitment to carbon neutrality for the region will require significant cooperation, collaboration, and commitment from Metro Vancouver, member jurisdictions, other orders of government, partner organizations, stakeholders, and the public.

Enclosed is a copy of the staff report that summarizes the proposed changes to *Metro 2040* that will result from *Regional Growth Strategy Amendment Bylaw No. 1285, 2019*. If you have any questions with respect to the proposed amendment please contact Heather McNell, Director of Regional Planning and Electoral Area Services by phone at 604-436-6813 or by email at Heather.McNell@metrovancover.org.

Mayor Darryl Walker and Council, City of White Rock
Amending Metro Vancouver 2040: Shaping our Future to Align with the IPCC Special Report on Global Warming of 1.5°C -
Bylaw No. 1295, 2019
Page 3 of 3

Yours sincerely,



Sav Dhaliwal
Chair, Metro Vancouver Board

SD/NC/st

cc: Carl Isaak, Director, Planning and Development Services, City of White Rock

Encl: Report dated October 31, 2019, titled "Amending Metro Vancouver 2040: Shaping our Future to Align with the IPCC Special Report on Global Warming of 1.5°C – Bylaw 1295, 2019" (Doc# 33424692)

33385170

APPENDIX B

MVRD Report to Regional Planning Committee titled “Amending *Metro Vancouver 2040: Shaping our Future* to Align with the IPCC Special Report on Global Warming of 1.5°C – Bylaw 1293, 2019



MVRD On Table Replacement Item G1.1

To: Regional Planning Committee

From: Sean Tynan, Acting Senior Planner, Regional Planning

Date: October 31, 2019 Meeting Date: October 11, 2019

Subject: **Amending *Metro Vancouver 2040: Shaping our Future* to Align with the IPCC Special Report on Global Warming of 1.5°C – Bylaw 1295, 2019**

RECOMMENDATION

That the MVRD Board:

- a) initiate a Type 3 minor amendment to *Metro Vancouver 2040: Shaping our Future* to reflect a commitment to a carbon neutral region by 2050, and an interim target of reducing greenhouse gas emissions by 45% from 2010 levels by 2030;
- b) give first, second, and third readings to “Metro Vancouver Regional District Regional Growth Strategy Amendment Bylaw No. 1295, 2019”; and
- c) direct staff to notify affected local governments and agencies as per Section 6.4.2 of *Metro Vancouver 2040: Shaping our Future*.

PURPOSE

This report recommends a Type 3 minor amendment to *Metro Vancouver 2040: Shaping our Future (Metro 2040)*, the regional growth strategy, for consideration by the Regional Planning Committee and MVRD Board.

BACKGROUND

Per Subsection 429 (d) of the *Local Government Act*, *Metro 2040* includes the region’s greenhouse gas emissions reduction target. The current reduction target in *Metro 2040* is 33% by 2020 and 80% by 2050 as compared to 2007 levels.

Climate 2050 is Metro Vancouver’s overarching long-term strategy guiding the region’s policies and collective actions to transition to a carbon neutral and climate resilient region over the next 30 years. As part of *Climate 2050*, at its meeting on July 26, 2019, the MVRD Board adopted the following resolution:

That the MVRD Board:

- a) endorse the proposed amendments to the *Climate 2050 Strategic Framework* to reflect a commitment to a carbon neutral region by 2050, and an interim target of reducing greenhouse gas emissions by 45% from 2010 levels by 2030;
- b) direct staff to bring forward a proposed amendment to *Metro 2040*, the regional growth strategy, to the Metro Vancouver Board for consideration, to incorporate revised greenhouse gas reduction targets (including interim targets).

33424692

Metro Vancouver Regional District

In addition, the Metro Vancouver Board Strategic Plan (2019-2022) direction for Regional Planning contains the following statement on climate change:

- 1.2 *Undertake a comprehensive update to Metro 2040 to prioritize climate change, align with the update to the Regional Transportation Strategy, and extend the timeframe to 2050.*

This report responds to the direction of the MVRD Board and the Metro Vancouver Board Strategic Plan by bringing forward a proposed amendment to *Metro 2040* to update the region's greenhouse gas emissions reduction target to align with the October 2018 Intergovernmental Panel on Climate Change Special Report on Global Warming of 1.5 °C above pre-industrial levels.

METRO 2040 GREENHOUSE GAS EMISSIONS REDUCTION TARGETS

Current Greenhouse Gas Emissions Reduction Targets and Policies in *Metro 2040*

Metro 2040 is the region's collective vision for managing growth in the region. Under Section 3.3.1 of *Metro 2040*, Metro Vancouver commits to:

Implement the strategies and actions of the Regional Growth Strategy which contribute to regional targets to reduce greenhouse gas emissions by 33 percent below 2007 levels by 2020 and 80 percent below 2007 levels by 2050...

Under Section 3.3.4, the role of municipalities is to:

Adopt Regional Context Statements which:

- a) *identify how municipalities will use their land development and transportation strategies to meet their greenhouse gas reduction targets and consider how these targets will contribute to the regional targets;*
- b) *identify policies and/or programs that reduce energy consumption and greenhouse gas emissions, and improve air quality from land use and transportation infrastructure, such as:*
 - *existing building retrofits and construction of new buildings to green performance guidelines or standards, district energy systems, and energy recovery and renewable energy generation technologies, such as solar panels and geoexchange systems, and electric vehicle charging infrastructure;*
 - *community design and facility provision that encourages transit, cycling and walking (e.g. direct and safe pedestrian and cycling linkages to the transit system);*
- c) *focus infrastructure and amenity investments in Urban Centres and Frequent Transit Development Areas, and at appropriate locations along TransLink's Frequent Transit Network;*

In addition, there are other actions to reduce greenhouse gas emissions included in other sections of *Metro 2040*.

Proposed Amendment to *Metro 2040* and Implications for Member Jurisdictions

The proposed change would replace the existing greenhouse gas emission reduction target in *Metro 2040* in accordance with the table below.

Current Greenhouse Gas Emissions Reduction Target in <i>Metro 2040</i>	Proposed Greenhouse Gas Emissions Reduction Target (Reflected in Climate 2050 Strategic Framework and aligned with the IPCC Special Report)
<ul style="list-style-type: none"> • 33% below 2007 levels by 2020 • 80% below 2007 levels by 2050 	<ul style="list-style-type: none"> • 45% reduction from 2010 levels by 2030 • Carbon neutral by 2050

The proposed amendment would not require a need for immediate updates to regional context statements. However, municipalities that are currently developing or updating their respective Official Community Plans, Community Energy and Emissions Plans or other strategic planning documents should consider aligning their greenhouse gas emissions reduction targets and actions with the regional targets. The next time regional context statements are developed or updated, each member jurisdiction will need to identify how the respective Official Community Plans are consistent with, or are working towards, the greenhouse gas emissions reduction targets in *Metro 2040*.

Section 6.3.4 of *Metro 2040* allows for some amendments to the regional growth strategy to be undertaken through a Type 3 Minor Amendment. A Type 3 amendment requires the adoption of an amendment bylaw passed by an affirmative 50%+1 weighted vote of the MVRD Board, and does not require a public hearing. Once initiated, affected local governments would receive written notice and be provided a minimum of 30 days to respond. Type 3 minor amendments have been used in the past as a means to amend *Metro 2040*. The proposed amendment bylaw is attached.

The proposed amendment was presented on September 20, 2019, to the Regional Planning Advisory Committee for comment. No comments were received.

ALTERNATIVES

1. That the MVRD Board:
 - a) initiate a Type 3 minor amendment to *Metro Vancouver 2040: Shaping our Future* to reflect a commitment to a carbon neutral region by 2050, and an interim target of reducing greenhouse gas emissions by 45% from 2010 levels by 2030;
 - b) give first, second, and third readings to “Metro Vancouver Regional District Regional Growth Strategy Amendment Bylaw No. 1295, 2019”; and
 - c) direct staff to notify affected local governments and agencies as per Section 6.4.2 of *Metro Vancouver 2040: Shaping our Future*.

2. That the MVRD Board receive for information the report dated September 16, 2019, titled “Amending *Metro Vancouver 2040: Shaping our Future* to Align with the IPCC Special Report on Global Warming of 1.5°C – Bylaw 1295, 2019” and direct staff to explore updating the regional growth strategy greenhouse gas emission reduction targets as part of the comprehensive update to *Metro 2040*.

Metro Vancouver Regional District

FINANCIAL IMPLICATIONS

If the MVRD Board chooses Alternative 1, the proposed amendment bylaw will be initiated and given first, second, and third readings, and staff will notify affected local governments and agencies to provide an opportunity to offer comment. The proposed amendment bylaw would then be brought back to the MVRD Board with any comments from the notification period for consideration of final reading. The notification period will be a minimum of 30 days and the amendment notice will be posted on the Metro Vancouver website.

If the MVRD Board chooses Alternative 2, the process for updating the greenhouse gas emission reduction target in *Metro 2040* will not be initiated at this time. *Metro 2040* would not be aligned with the recent IPCC Special Report and will be inconsistent with MVRD Board direction to update the *Climate 2050 Strategic Framework*. Staff would then consider the updated greenhouse gas reduction target as part of the development of *Metro 2050*. This would delay updating the target until mid-2022.

SUMMARY / CONCLUSION

This report brings forward a recommendation to update the greenhouse gas emission reduction targets contained in *Metro 2040* to pursue a carbon neutral region by 2050, with an interim target of 45% reduction by 2030. Including this target in *Metro 2040* at this time is consistent with recent MVRD Board direction as well as the 2019-2022 Board Strategic Plan and the *Climate 2050 Strategic Framework*. Alternatively, with the update to *Metro 2040* underway, updating the greenhouse gas emissions target in the regional growth strategy can also be implemented as part of the development of *Metro 2050*, the updated growth strategy, which is anticipated to be finalized and adopted in mid-2022.

Metro Vancouver can set the path towards carbon neutrality for the region, but it will not be able to achieve the targets on its own. To obtain the necessary reductions in regional emissions, significant cooperation, collaboration, and commitment will be required from member jurisdictions, other orders of government, partner organizations, stakeholders, and the public. The new greenhouse gas emissions reduction target would need to be considered by member jurisdictions the next time their respective regional context statements are updated. In the interim, municipalities currently updating their Official Community Plans, Community Energy and Emissions Plans or other strategic planning documents may wish to consider aligning their greenhouse gas emissions reduction targets with Metro Vancouver and the IPCC Special Report. Staff recommend Alternative 1.

Attachment

Metro Vancouver Regional District Regional Growth Strategy Amendment Bylaw No. 1295, 2019

References

1. [IPCC Special Report on Global Warming of 1.5°C](#)
2. [Aligning Climate 2050 with the IPCC Special Report on Global Warming of 1.5°C](#)

32665793

Metro Vancouver Regional District

Passed and finally adopted this _____ day of _____, _____.

Sav Dhaliwal, Chair

Chris Plagnol, Corporate Officer

ATTACHMENT

**METRO VANCOUVER REGIONAL DISTRICT
BYLAW NO. 1295, 2019
A Bylaw to Amend "Greater Vancouver Regional District Regional Growth Strategy
Bylaw Number 1136, 2010"**

WHEREAS:

- A. Metro Vancouver Regional District's board of directors (the "Board") adopted the "Greater Vancouver Regional District Regional Growth Strategy Bylaw Number 1136, 2010" on July 29, 2011 (the "Regional Growth Strategy");
- B. The Board wishes to revise the greenhouse gas emissions reduction targets included in the Regional Growth Strategy;
- C. In accordance with Regional Growth Strategy Section 6.3.4(j), all amendments to the Regional Growth Strategy that are not identified in Sections 6.3.1 or 6.3.3 are considered Type 3 minor amendments; and
- D. Metro Vancouver Regional District wishes to amend "Greater Vancouver Regional District Regional Growth Strategy Bylaw Number 1136, 2010".

NOW THEREFORE the Board of Metro Vancouver Regional District enacts as follows:

- 1. "Greater Vancouver Regional District Regional Growth Strategy Bylaw Number 1136, 2010" is hereby amended as follows:

Regional Growth Strategy Section 3.3.1 is deleted and the following is substituted in its place:

3.3.1 Implement the strategies and actions of the Regional Growth Strategy that contribute to regional targets to reduce greenhouse gas emissions by 45 percent below 2010 levels by 2030 and to achieve a carbon neutral region by 2050. Figure 3 identifies examples of strategies and actions contained in the Regional Growth Strategy to address climate change.

- 2. The official citation of this bylaw is "Metro Vancouver Regional District Regional Growth Strategy Amendment Bylaw No. 1295, 2019". This bylaw may be cited as "Regional Growth Strategy Amendment Bylaw No. 1295, 2019".

Read a first time this _____ day of _____, _____.

Read a second time this _____ day of _____, _____.

Read a third time this _____ day of _____, _____.

THE CORPORATION OF THE
CITY OF WHITE ROCK
CORPORATE REPORT

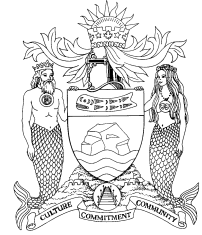

DATE: January 13, 2020
TO: Mayor and Council
FROM: Eric Stepura, Director of Recreation and Culture
SUBJECT: 2019 Sea Festival Survey Results

RECOMMENDATION

THAT Council receive for information the corporate report dated January 13, 2020 from the Director of Recreation and Culture titled "2019 Sea Festival Survey Results."

INTRODUCTION

This corporate report is in response to a June 24, 2019 Council request for business and attendee surveys on the value of the White Rock Sea Festival.

PAST PRACTICE / POLICY / LEGISLATION

At the June 24, 2019 Regular Council meeting, Council made the following directives regarding the 2019 White Rock Sea Festival:

1. THAT Council directs staff to approach the Business Improvement Association (BIA) to conduct a survey on the value of the Sea Festival for their businesses members in order to assess the impact it has on sales; and
2. THAT Council directs staff to work with Explore White Rock to conduct a survey with the attendees of the Sea Festival to measure the economic and social impact of the event.

ANALYSIS

BIA Survey Results

At the request of the City, in September 2019, the White Rock BIA conducted a survey of waterfront businesses regarding the impact that the 2019 White Rock Sea Festival had on local businesses. Although there were only a few responses, the results were very positive.

The following are the BIA's survey results:

- 100% of businesses responding were positively impacted by the Sea Festival;
- 100% of the businesses responding found the event useful to their business (i.e. increased sales); and
- 100% of businesses responding are interested in participating more actively in next year's Sea Festival

Comments include:

- The Sea Festival brings a crowd to the beach, which is good for business
- Participating as a vendor at Sea Festival got our business new customers

Additional Feedback:

- More detailed advertising of the schedule of activities
- Start the torchlight parade later - 7:45 pm is way too early, it needs to be dark so the colors of the lights really pop.

Explore White Rock Survey Results

On August 3 and 4, 2019 Explore White Rock conducted a survey of people attending the 2019 White Rock Sea Festival. The survey was conducted by members of the Explore White Rock Street Team (summer students employed by Explore White Rock). The survey consisted of 16 questions. The results were recorded on portable tablets, then tabulated into the attached report (Appendix A). Eighty one (81) responses were received.

Overall the results were very positive about their visitor experiences. Some of the highlights include:

- Over 60% of responses were from people ages 19-49
- 90.2% were residents of the Lower Mainland (i.e. 42% were White Rock residents, 24.7% Surrey residents and 23.5% other Lower Mainland municipalities) and 9.8% were visiting from outside the Lower Mainland.
- 64.2 % of respondents have attended Sea Festival before, and 33.3% have been attending Sea Festival for several years
- The most enjoyed elements included music, vendors and activities
- Parking was not a major issue with the majority of the respondents
- The children's activities were rated very high
- The majority of respondents indicated that they would spend between ten dollars (\$10) and seventy five dollars (\$75) at Sea Festival
- 76.5% indicated that they will attend the Sea Festival again in 2020
- Additional feedback on future festival improvements include:
 - Free or cheaper parking
 - More sand castles
 - Pier re-opened
 - Extend the children's activities to run later
 - Shuttle service between East and West Beach and from the waterfront to the Town Centre after the parade and fireworks

CONCLUSION

This corporate report is provided for information and in response to a June 24, 2019 Council request for business and attendee surveys on the value of the White Rock Sea Festival. The results of both the survey of waterfront businesses, and the survey of event attendees were very positive regarding the value of the 2019 White Rock Sea Festival experience.

Respectfully submitted,



Eric Stepura
Director of Recreation and Culture

Comments from the Chief Administrative Officer:

This corporate report is provided for information.



Dan Bottrill
Chief Administrative Officer

Appendix A: Explore White Rock Attendee Survey

APPENDIX A

Seafest experience 2019

81 responses

Age group of attendee

81 responses

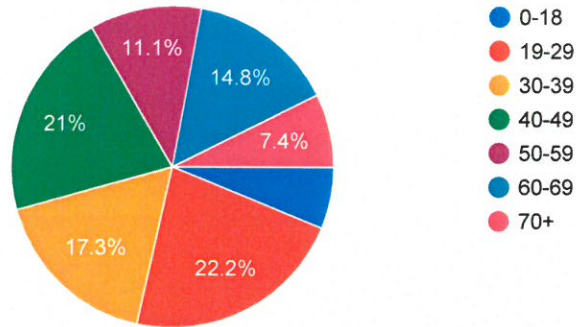

Where are you from?

81 responses

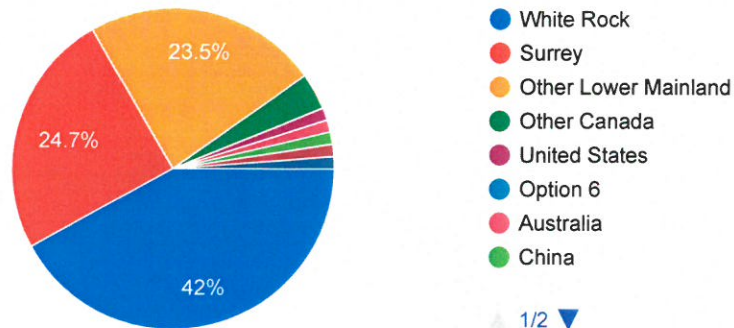

If "other" where from?

17 responses

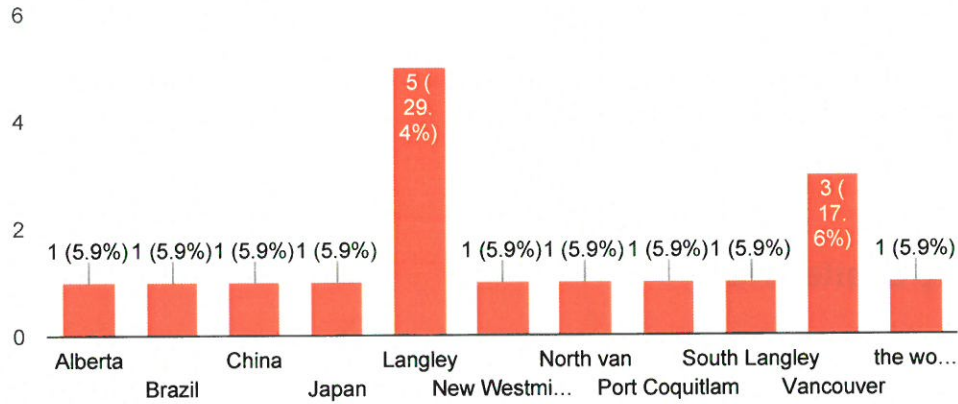

How did you hear about SeaFest?

81 responses

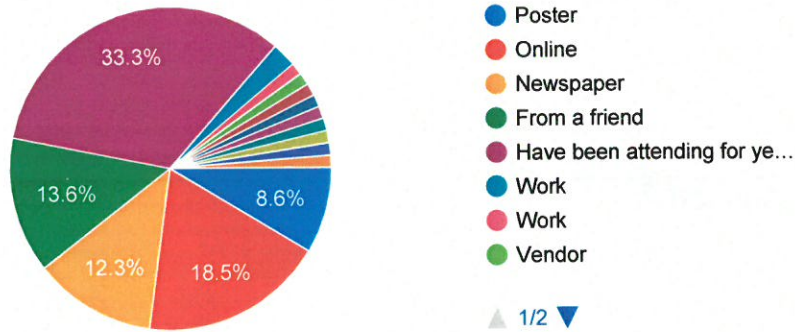

If "other" then how did you hear about it?

3 responses

Vendor

Here
for work

Was
on site and discovered the festival

Have you attended SeaFest before?

81 responses

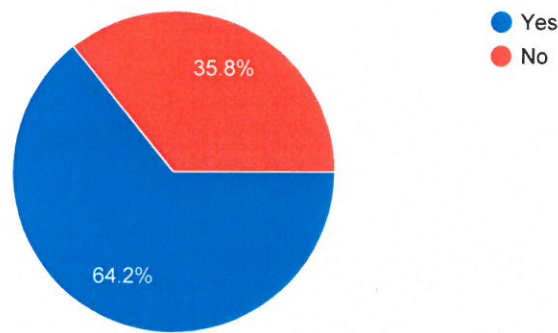

If "yes" then how many years have you been?

44 responses

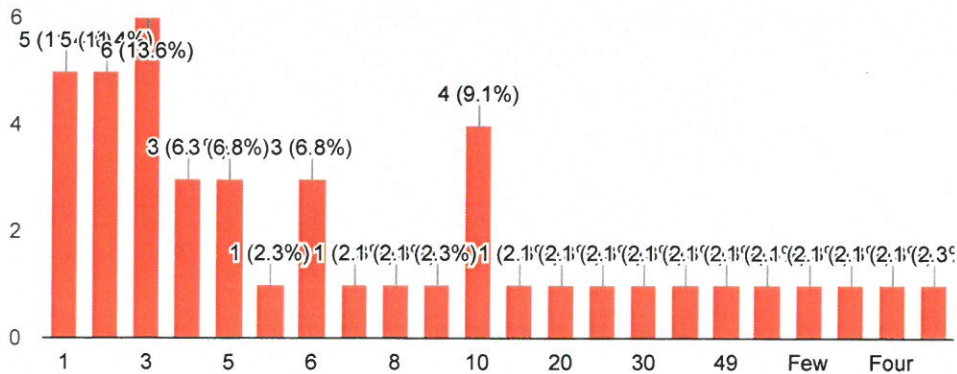

What are you enjoying most about today?

81 responses

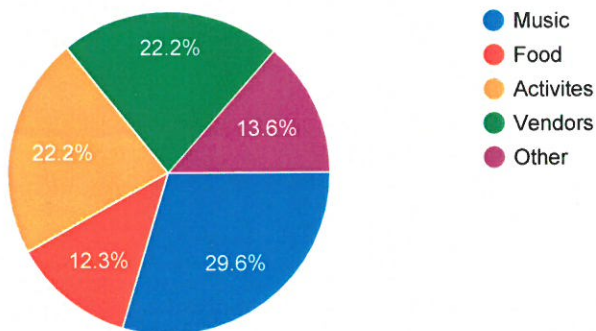

If "other" then what are you enjoying most?

12 responses

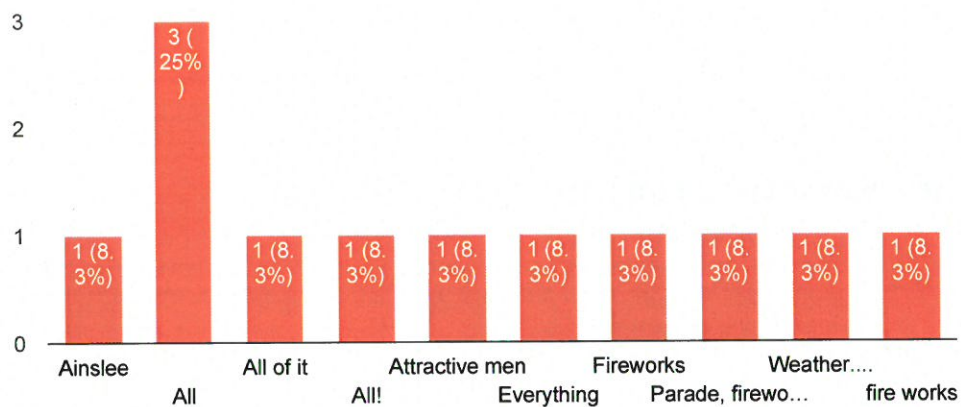

How did you enjoy the activities offered?

79 responses

How did you enjoy the music?

78 responses

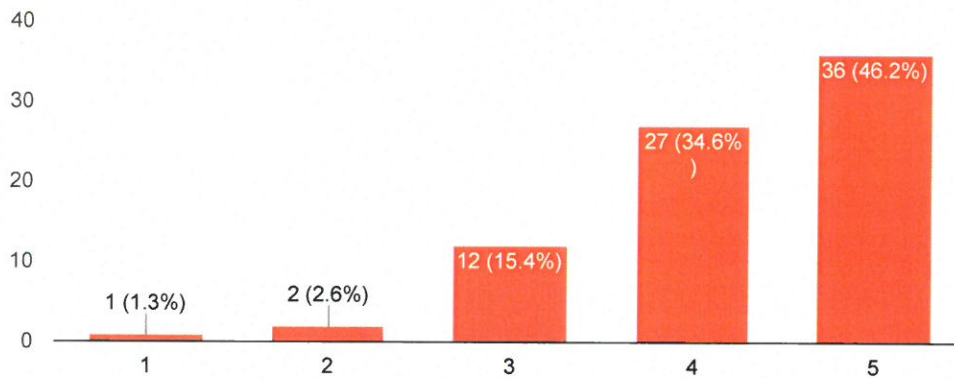

How did you enjoy the vendors?

81 responses

How was your experience with parking?

74 responses

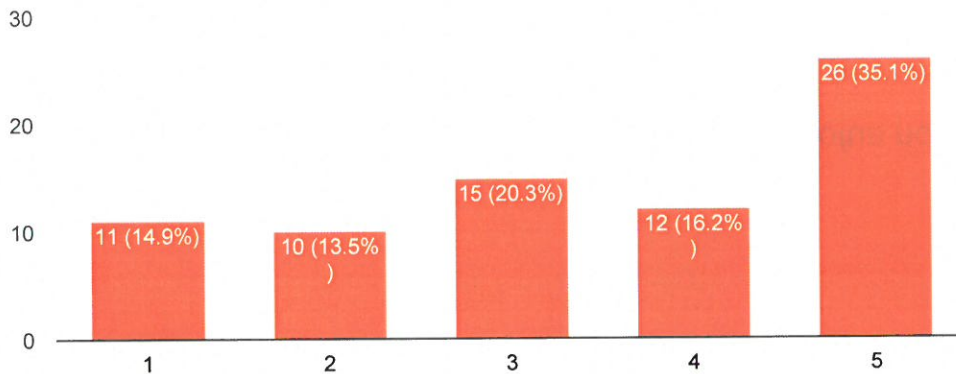

How did you enjoy the children's activities?

64 responses

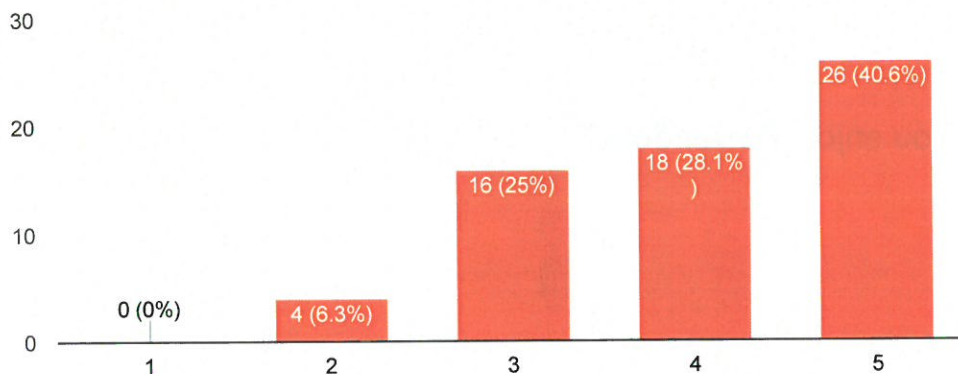

How much do you think you will spend at SeaFest?

81 responses

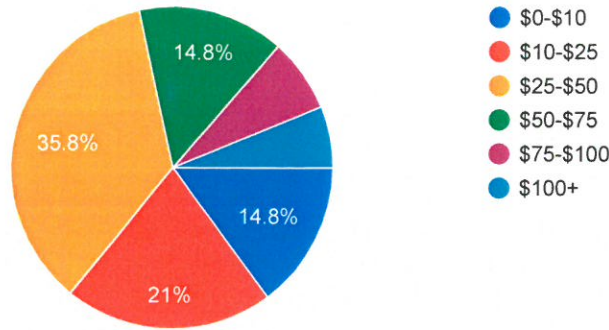

How much do you think you will spend at local restaurants, cafés, or gift shops

79 responses

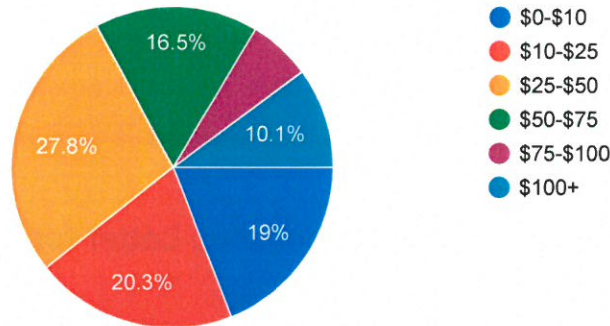

Overall experience so far

81 responses

Will you attend next year?

81 responses

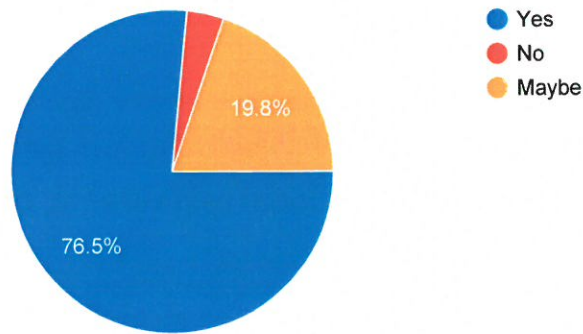

Is there anything the Festival Committee could do better for next year?

27 responses

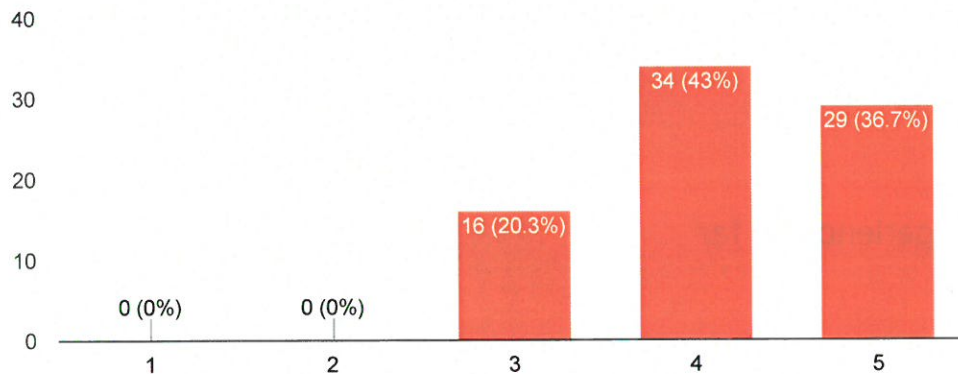

Online promotion

Free parking

Nothing

Cheaper
parking

Can't
say. Good so far.

Sand
castles

No
comment

Love
wr

If we
would've known about it

More
Ainslee

More
samples

Pierre
open

More
affordable parking. The kids activities ended at 4pm at east side, which is too
early, not much to do before fireworks. Please extend the activities.

Free
ice cream

More
for teens

Shuttle
between east and west beach, the walk is too long! More free food/vendors that
will give out free things. More local, young bands performing! More activities.
More things geared towards young adults/teens.

Do
shuttles again. Ridiculous no shuttles for seniors and disabled

Shuttles
especially for seniors and disabled. Why do you not have them this year. We rely
on this service

Fireworks
were amazing!! Car show was very cool. More late movie options and more food
options.

Better
parking, more activities for people in their 20s. Enjoyed the fire
works

Nope

Put
more activities in between semiamoo and west park. Put more shades in memorial
park

This content is neither created nor endorsed by Google. [Report Abuse](#) - [Terms of Service](#) - [Privacy Policy](#)

Google Maps

THE CORPORATION OF THE
CITY OF WHITE ROCK
CORPORATE REPORT

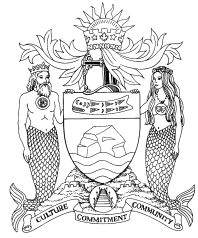

DATE: January 13, 2020
TO: Mayor and Council
FROM: Sandra Kurylo, Director of Financial Services
SUBJECT: White Rock Lawn Bowling Club Loan Request

RECOMMENDATIONS:

THAT Council consider the information presented in this corporate report and:

1. Confirm if Council intends to:
 - a. Enter into a partnering agreement with the White Rock Lawn Bowling Club;
 - b. Extend the licence with the White Rock Lawn Bowling Club; and
 - c. Lend the White Rock Lawn Bowling Club an amount of \$62,000 to assist in the financing of the replacement of its artificial turf, subject to undertaking the legislative processes described in this corporate report; and
 2. If Council intends to lend \$62,000 to the White Rock Lawn Bowling Club for this purpose, direct staff to proceed with the next steps as outlined in this corporate report.
-

INTRODUCTION:

At the Council meeting of December 16, 2019, the White Rock Lawn Bowling Club (WRLBC) requested that the City lend it \$62,000 to assist in financing the replacement of its artificial turf. This report provides background information and the required legislative process should Council wish to pursue providing WRLBC with a loan.

PAST PRACTICE/POLICY/LEGISLATION:

Section 25 of the Community Charter prohibits the City from providing financial assistance to a business, subject to certain exemptions. Section 21 of the Community Charter permits the City to provide financial assistance if a partnering agreement is entered into. Section 24 of the legislation requires that public notice of the City's intention to lend money to an organization must be given, in accordance with Section 94, before the assistance is provided.

Lending money to organizations is rare for a municipality. As far as staff is aware, the City has lent money to non-profit tenants on two occasions in the past. In 2008, the City provided a 10-year loan to the White Rock Lawn Bowling Club for the initial purchase and installation of its artificial turf. In 2012, the City provided a 10-year loan to the Peace Arch Curling Club to assist in financing the purchase of new kitchen equipment for their leased premises in the Centre for Active Living.

ANALYSIS:

As stated above, lending money to organizations is not a common practice for municipalities. This is because there could be a financial risk of the loan not being repaid, and the money being lent belongs to the taxpayers. As well, the City has many partners and tenants who require financial assistance from time to time. If this becomes a common practice of the City, more partner organizations or tenants may request loans from the City and it may be difficult not to approve them. This may not necessarily be in the best interests of the taxpayers.

The current licence between the City and the WRLBC is for the five years, August 1, 2018 to July 31, 2023. It contains one renewal clause of one (1) additional five (5) year term. It should be noted that the WRLBC promptly made all principal and interest payments on its previous loan from the City. The loan was fully repaid ahead of schedule, in 2016.

Attached, as Appendices A and B, is correspondence from the WRLBC, providing background and financial information. The estimated cost of purchasing and installing the new carpet is \$180,000. The financial statements provided note that as of September 30, 2018, the Club had internally restricted funds on hand for this purpose of \$94,425. The President of the WRLBC provided an update that \$118,000 has now been raised for this purpose, leaving an outstanding amount of \$62,000. It is noted that the financial statements provided have not been audited or reviewed by an independent certified accountant. However the Club has advised they have been prepared by a Club member who is a certified accountant, and reviewed by the Financial Committee of the Board.

Legislative Requirements

Should the City wish to pursue lending the WRLBC the money, it first must enter into a partnering agreement pursuant to Section 21 of the Charter, whereby the Club would provide services on behalf of the City and the loan would be authorized under that agreement. This is necessary as it permits the City to provide financial assistance, which may otherwise be prohibited under section 25 of the legislation.

The steps required are as follows:

1. Prepare a partnering agreement with the WRLBC, as described above;
2. Prepare a loan agreement, including all of the terms and conditions of the loan. In this case, staff recommend a 10-year term with interest being charged annually at the average prime interest rate for the previous calendar year. Further detailed terms and conditions, such as the form of security, will be provided in the agreement;
3. Prepare an extension to the WRLBC licence, so it ends no earlier than the term of the loan;
4. Obtain Council's approval of the above documents and its direction to proceed with public notice of its intent to lend the money to the WRLBC, in accordance with Sections 24 and 94 of the Community Charter. Execute the partnering agreement prior to placing the public advertisement;
5. Execute the loan agreement and licence amendment after the notice period; and
6. Approve all plans before construction proceeds.

Staff have advised the WRLBC that should Council confirm its intent to proceed as described, the WRLBC would be required to reimburse the City for associated legal and advertisement costs, estimated to be \$3,000 to \$5,000. The Club has agreed to reimburse these costs.

CONCLUSION:

It is recommended that Council consider the information presented in this corporate report and provide direction to staff on whether or not Council intends for the City to enter into a partnering agreement with the White Rock Lawn Bowling Club, extend its licence, and lend it \$62,000 to assist in the financing of the replacement of its artificial turf.

Respectfully submitted,



Sandra Kurylo
Director of Financial Services

Comments from the Chief Administrative Officer:

I concur with the recommendations in this corporate report.



Dan Bottrill
Chief Administrative Officer

Appendix A: Correspondence dated December 16, 2019 from the White Rock Lawn Bowling Club

Appendix B: Correspondence dated May 23, 2019 from the White Rock Lawn Bowling Club

December 16, 2016

We are here today to ask the City of White Rock for a loan of \$62,000 to help fund the replacement of our ageing artificial green. The City is the registered owner of the land and the premises which is the White Rock Lawn Bowling Club. The estimated cost of this project is \$180,000 and the club has saved \$118,000 towards this project, leaving a short fall of \$62,000.

We owned and operated our club from 1934 to 1974, at which time the property was sold to the City for \$40,000. By 2008 the natural green was no longer playable due to serious drainage problems so we approached the City for financial assistance. With a loan from the City, a Government grant and our own savings we were able to replace the existing grass green with an artificial green allowing year round play. This loan was paid in full in November 2017.

Constant wear on a daily basis for over eleven years has caused the surface great stress and deterioration. Without a properly functioning green we won't have a bowling club. The green is the lifeline and mainstay of a bowling club. We feel the only option for our club to continue to provide a viable playing surface is to replace the existing carpet.

What started out as a bowling club is much more today. Our membership is strong and growing with over 155 members between 58 and 99 years old. We provide a safe and welcoming environment for all members who want to enjoy an active and healthy lifestyle, meet and socialize, or just be there to offer support for those who need it. If time permitted I could provide you with 155 stories of just how important this club is to its members.

We are a very active club with daily drop in games, leagues, tournaments, and various competitions with clubs from all over the lower mainland.

Each year we work with the local schools to provide qualified coaches to introduce the students to the game of bowls as a part of their physical education program. Not only do the students learn to bowl, they enjoy meeting and interacting with our members, but just as important, it gives our members an opportunity to connect with students and hopefully inspire them to enjoy and play this wonderful game.

Please help us to guarantee the future of this amazing community asset by supporting us in sustaining this prestigious sports and social club. Thank you.

Gayle Saunders, President
Paul Beaumont, Project Manager
White Rock Lawn Bowling Club

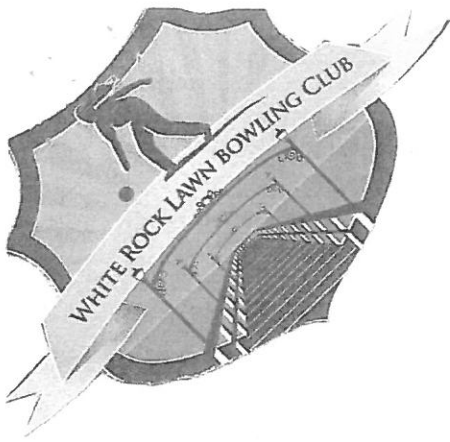

WHITE ROCK LAWN BOWLING CLUB
 1079 Dolphin Street
 White Rock, B.C.
 V4B 4B4

RECEIVED

MAY 24 2019

May 23, 2019

CITY OF WHITE ROCK
 ADMINISTRATION

Corporation of the City of White Rock
 15322 Buena Vista Avenue
 White Rock, British Columbia, V4B 1Y6

Attention: Mayor Darryl Walker

Please find enclosed herewith our request for financial assistance in replacing our existing artificial bowling carpet. I have included a brief history of who we are and why we are approaching the City of White Rock with this request.

- 1) Who are we? We are a sports club that began as a group of neighbours, who in 1934 first played the “sport of bowls” in their back yard, evolving into a bowling club that has produced many fine athletes who not only have excelled in the Lower Mainland, but have competed in the Provincial, National and International arenas. Our athletes are widely respected not only for outstanding play but their fine sportsmanship. The club has hosted Local, District, Provincial and National Tournaments, as well as visitations from other cities. We took the White Rock Lawn Bowling Club to the world and invited the world back to the City of White Rock.
- 2) Brief History: We owned and operated our club from 1934 to 1974 at which time the property was sold to the City of White Rock for \$40,000.00. The club continued to grow in membership throughout the years but the greens became more and more unplayable due to serious drainage problems. In 2008 we approached the City of White Rock for financial assistance. With the \$100,000 our club raised, a \$110,000 Government grant and a \$100,000 interest bearing loan from the City we were able to replace the existing grass green with an artificial green. The final repayment of this loan was submitted November 2017.
- 3) With this new all-weather artificial green we were able to play year round. We started a winter bowling season and invited our “sister” club at Mann Park to participate, strengthening the bond between both clubs. Our membership is strong with a current roster of over 160 members and our club continues to prosper. Our youngest member is 52 years old and our oldest member will be celebrating his 98th birthday in 2019. We are 100% managed by volunteers with in excess of 2000 volunteer hours recorded each year. We provide a safe, welcoming, healthy interactive lifestyle for our community. The importance of the social aspects of the club, dinners, dances, afternoon card games and various social activities during the year cannot not be over emphasised. We are not just a bowling club, we are a “people” club.
- 4) We are committed to our community. The club in conjunction with our local schools, facilitates workshops in the spring. We have provided this service for the past number of years. This is a

positive direction for the club as this gives us the opportunity to showcase our club, what we are all about, and to broaden our community membership base. Our greens are well used year round with various leagues, tournaments and daily drop-in games. The existing green is now in it's eleventh year and is in dire need of replacement. We feel the only option for our club to continue to provide a viable playing surface is to replace the existing carpet.

- 5) The City is the registered owner of the land and the premises which is the White Rock Lawn Bowling Club. In August 2018 we renewed our Licence of Occupation for a term of five (5) years, expiring July 31, 2023 with a renewal of this licence for one (1) additional term of five (5) years providing we give such notice to the City ninety (90) days prior to the end of the existing term.
- 6) We request a loan not to exceed \$86,000 so that we can make the necessary arrangements to have the carpet replaced in the spring of 2020.

We look forward to discussing this with you in further detail and answering any questions you might have.

Sincerely,



Gayle Saunders, President

Phone: 604-385-1154.

email: gaylesaunderswr@gmail.com

Attached: Budget 2018 – 2019
Balance Sheet, September 2018
Statement of Receipts and Disbursements, September 2018
Total estimated cost of carpet replacement

**STATEMENT OF RECEIPTS AND DISBURSEMENTS
BUDGET 2018-2019**

	<u>Actual 2017-2018</u>	<u>Budget 2018- 2019</u>
<u>Receipts/Income</u>		
Membership Annual Fees	24,765.00	25,000
Locker Rentals	1,005.00	1,000
Aggregate Fees (Tues, Thurs, Sat)	1,037.00	1,000
Aggregate Drop ins	343.00	300
Tournaments; Inter-club & V&D fees	1,687.00	1,700
League	575.00	600
Winter Membership	1,200.00	1,200
Bar Sales - Liquor	11,307.00	11,000
Bar Sales - pop	428.20	400
Social/Hospitality	3,054.00	3,000
Bowl Supplies	-	-
Grants	1,700.00	1,700
Interest	425.25	500
50/50 Draws	537.50	500
Club House Rentals	2,905.00	3,000
Sponsorship Contributions/Donations	350.00	300
	-	
Total Receipts	<u>51,318.95</u>	<u>51,200</u>

WHITE ROCK LAWN BOWLING CLUB

BALANCE SHEET

As at September 30, 2018

ASSETS

Bank - Chequing	6,423.20	
Bank - Savings	12,814.72	
Internally Restricted Controlled Funds / Carpet - Note 1	94,424.91	
Gaming Account - Restricted re 50/50	1,676.58	
GIC/Liquor Security/Oct 19/18 @ 1.2%	1,581.23	
Accounts Receivable -Community Events	943.00	
Liquor Inventory - Sept 30/2018	602.00	
Pop and Snacks Inventory - Sept 30, 2018	100.00	
Bar Float - Sept 30/2018	147.10	
House Cleaning Float	200.00	
Membership Shares / Coast Capital	5.00	
	<u>118,917.74</u>	<u>118,917.74</u>

LIABILITIES AND NET WORTH

Liabilities

Accounts Payable	-	-
------------------	---	---

Net Worth

Balance - Beginning of period	117,790.66	
Current period surplus / deficit	<u>1,127.08</u>	
Balance - End of Period	<u>118,917.74</u>	<u>118,917.74</u>
		<u><u>118,917.74</u></u>

NOTE 1

Internally Restricted Controlled Funds / Carpet consist of the following:

	<u>Maturity Date</u>	<u>Interest Rate</u>	<u>Amount</u>
GIC - better-than-cash	17-Oct-18	1.65%	22,078.13
GIC/Rising rate - redeemable annually	13-Jun-20	1.15/1.25/3.0	21,854.62
35 month term (locked in)	21-Aug-20	2.35%	30,280.60
GIC - better-than-cash	26-Feb-19	1.40%	10,211.56
GIC - redeemable annually	15-May-20	2.25%	<u>10,000.00</u>
			94,424.91

**STATEMENT OF RECEIPTS AND DISBURSEMENTS
MONTH OF SEPTEMBER 2018**

	<u>Current Month</u>	<u>Year To Date</u>	<u>Annual Budget</u>
<u>Receipts/Income</u>			
Membership Annual Fees	-	24,765.00	22,000
Locker Rentals	-	1,005.00	900
Aggregate Fees (Tues, Thurs, Sat)	-	1,037.00	1,100
Aggregate Drop ins	-	343.00	200
Tournaments; Inter-club & V&D fees	847.00	1,687.00	1,800
League	-	575.00	600
Winter Membership	-	1,200.00	1,400
Bar Sales - Liquor	1,637.00	11,307.00	8,800
Bar Sales - pop	82.10	428.20	450
Social/Hospitality	1,512.00	3,054.00	2,100
Bowls Supplies	-	-	100
Grants	-	1,700.00	100
Interest	2.80	425.25	1,100
50/50 Draws	200.00	537.50	450
Club House / Community Event Rentals	900.00	2,905.00	1,500
Sponsorship Contributions/ Donations	200.00	350.00	-
Accounts Receivable	-	-	
	<u>5,380.90</u>	<u>51,318.95</u>	<u>42,600</u>
Less: non-revenue receipts	-	-	
Total Revenue	<u><u>5,380.90</u></u>	<u><u>51,318.95</u></u>	<u><u>42,600</u></u>

**STATEMENT OF RECEIPTS AND DISBURSEMENTS
BUDGET 2018-2019**

<u>Disbursements/Expenses</u>	<u>Actual 2017-2018</u>	<u>Budget 2018- 2019</u>
Administrative	678.89	600
Internally restricted fund(carpet)	15,000.00	17,000
Electricity, Water, Natural Gas, Phone	3,255.38	3,300
Aggregate / Tues/Thurs/Sat - Prizes	1,037.00	1,000
Tournament (V&D/Inter-Club) expenses	752.16	800
Regular League	575.00	600
Social/Hospitality	2,809.24	2,800
Buildings: Clubhouse Maintenance	2,236.69	2,500
Grounds: Maintenance & Landscaping	1,063.61	1,300
Property & Liability Insurance. W.R.	880.49	925
Liability Insurance: BC Bowls	450.00	450
Liquor Purchases and PST	8,533.37	8,600
Liquor License / Register new directors	555.05	570
Bar Supplies	481.53	600
Membership dues - BC Bowls/Bowls Canada/	4,432.00	4,600
Publicity	154.50	500
Bowl Supplies	-	1,000
Engraving	252.35	250
Property taxes - Sewage	1,160.00	1,200
Website Design Maintenance	20.24	250
Grant Expenditure	1,689.31	1,500
Total Disbursements	46,016.81	50,345
Less: Internally Restricted funds/savings	(15,000.00)	(17,000)
Operating expenses	31,016.81	33,345
Net Surplus / Deficit	20,302.14	17,855

**STATEMENT OF RECEIPTS AND DISBURSEMENTS
MONTH OF SEPTEMBER 2018**

	<u>Current Month</u>	<u>Year To Date</u>	<u>Annual Budget</u>
<u>Disbursements/Expenses</u>			
Administrative	49.60	678.89	500
Internally restricted fund(carpet)	-	15,000.00	15,000
Electricity, Water, Natural Gas, Phone	262.74	3,255.38	3,300
Aggregate / Tues/Thurs/Sat - Prizes	-	1,037.00	1,100
Tournament (V&D/Inter-Club) expenses	-	752.16	800
Regular League	575.00	575.00	550
Social/Hospitality	1,173.74	2,809.24	2,700
Buildings: Clubhouse Maintenance	687.54	2,236.69	2,500
Grounds: Maintenance & Landscaping	74.09	1,063.61	1,100
Property & Liability Insurance. W.R.	-	880.49	850
Liability Insurance: BC Bowls	450.00	450.00	450
Liquor Purchases and PST	747.43	8,533.37	6,300
Liquor License / Register new directors	-	555.05	570
Bar Supplies	8.94	481.53	650
Membership dues - BC Bowls/Bowls Canada/V&D	-	4,432.00	4,100
Publicity	-	154.50	600
Bowls Supplies	-	-	100
Rules Books/Score Cards	-	-	150
Engraving	120.74	252.35	85
Property taxes - Sewage	104.00	1,160.00	1,190
Website Design Maintenance	-	20.24	250
Purchase of AED Plus	-	1,689.31	-
Total Disbursements	4,253.82	46,016.81	42,845
Less: Internally Restricted funds/savings	-	(15,000.00)	(15,000)
Operating expenses	4,253.82	31,016.81	27,845
Net Surplus / Deficit	1,127.08	20,302.14	14,755

White Rock Lawn Bowling Club

Proposed Remedial Works to Playing Surface

Breakdown of Cost Estimate for Works

<u>Item Description</u>	<u>Cost</u>
1. Lift and dispose of existing carpet	10,000.00
2. Supply, deliver and install Mastergreen or Pro Green Plus World Bowls Approved carpet including Re-installation of existing underlay Cover bankings Mark out rinks Live bowls and jack markers, delivery mats and jacks	88,110.00
3. Installation of 10mm cap on e-layer	45,000.00
4. Dales Pro-weave Sports Vacuum incl PST and GST	5,017.60
5. Independent survey of new e-layer surface	1,500.00
6. Contingency for tax and duty, etc.	15,000.00
7. Contingency for unforeseen issues - allow 10%	16,000.00
<u>Total estimated cost</u>	<u>\$180,627.60</u>

THE CORPORATION OF THE
CITY OF WHITE ROCK
CORPORATE REPORT

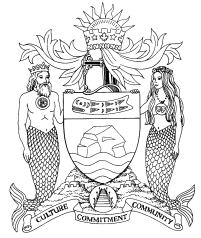

DATE: January 13, 2020
TO: Mayor and Council
FROM: Sandra Kurylo, Director of Financial Services
SUBJECT: Revenue Anticipation Borrowing Bylaw, 2020, No. 2324

RECOMMENDATION

THAT Council receive for information the corporate report dated January 13, 2020 from the Director of Financial Services, titled “Revenue Anticipation Borrowing Bylaw, 2020, No. 2324.”

INTRODUCTION

This corporate report presents White Rock Revenue Anticipation Borrowing Bylaw, 2020, No. 2324 to Council for consideration of first, second and third readings. It is recommended to be adopted in the event that the City has to borrow money to meet 2020 expenditures prior to the collection of property taxes.

PAST PRACTICE/POLICY/LEGISLATION

Section 177 of the *Community Charter* authorizes Council, by bylaw adopted without the assent of the electors or the approval of the inspector, to borrow money as may be required to meet current lawful expenditures. When collected, revenue from property taxes must be used as necessary to repay this debt.

ANALYSIS

It has been standard practice that Council adopts a bylaw for this purpose each year. This is required by the City’s bank to ensure that the City’s line of credit is available on demand if needed. While there may be sufficient cash in reserves to cover day-to-day expenditures during this interim period, having the line of credit readily available is considered prudent for cash management purposes, including maximizing returns on the City’s investment portfolio.

CONCLUSION

It is recommended that White Rock Revenue Anticipation Borrowing Bylaw, 2020, No. 2324 be given first, second and third readings.

Respectfully submitted,



Sandra Kurylo
Director of Financial Services

Comments from the Chief Administrative Officer:

This corporate report is provided for Council's information.



Dan Bottrill
Chief Administrative Officer

THE CORPORATION OF THE
CITY OF WHITE ROCK
CORPORATE REPORT

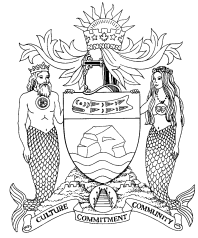

DATE: January 13, 2020
TO: Mayor and Council
FROM: Jim Gordon, Director of Engineering & Municipal Operations
SUBJECT: Climate Action Initiatives

RECOMMENDATIONS

THAT Council:

1. Receive for information the corporate report dated January 13, 2020 from the Director of Engineering & Municipal Operations titled “Climate Action Initiatives”;
 2. Endorse the ongoing initiatives discussed in this corporate report;
 3. Consider including \$15,000, funded from an operating reserve or the City’s accumulated surplus, to fund a top up to the Provincial Better Homes Plan as part of upcoming financial deliberations of the 2020 – 2024 Financial Plan; and
 4. Consider including \$20,000, funded from Climate Action Revenue Incentive Program (CARIP) grants to cover the installation of one new electric vehicle charging station with two ports as part of upcoming financial deliberations of the 2020 – 2024 Financial Plan.
-

INTRODUCTION

Kaitlyn Blair appeared as a delegation at the November 4, 2019 Council meeting to discuss a Climate Action Protest and the need to take action against the Climate Crisis. Ms. Blair referenced the letter attached as Appendix A in her presentation.

Council directed that a corporate report be brought forward that will outline and/or comment on how the City may achieve the goals noted in Ms. Blair’s letter, including information regarding the feasibility of potable water stations throughout the City, promote the stations and have one located on the Promenade. This corporate report discusses the items in Ms. Blair’s letter and environmental issues in general.

PAST PRACTICE / POLICY / LEGISLATION

The Metro Vancouver Integrated Solid Waste Resource Management Plan (ISWRMP) applies to White Rock as a member of Metro Vancouver. Similarly, Translink’s Regional Transportation Strategy (RTS) applies to White Rock. The City reports to the Provincial Climate Action Revenue Incentive Program (CARIP).

ANALYSIS

White Rock developed a number of environmental and climate action plans over the past ten years. The Environmental Advisory Committee (EAC) recently compiled information on these plans that include the 2008 Environmental Strategic Plan (ESP), the 2010 Community Climate Action Plan (CCAP) and the 2011 OCP that was amended to include CCAP values. The recent OCP update includes environmental initiatives and Greenhouse Gas (GHG) reduction targets and connection to Metro and Provincial climate change initiatives.

As illustrated above, plans are in place; however, the challenge is in developing climate change actions that are financially and socially acceptable. White Rock has taken some steps such as the green waste collection program, electric vehicles where feasible, the green Operations Building, facilities upgrades etc. The necessary next steps needed to comply with the various plans will be more expensive and more challenging than the steps taken to date.

Various initiatives, including the ones outlined in Ms. Blair's letter, and their challenges are discussed below.

Waste Reduction

The Metro Vancouver Integrated Solid Waste Resource Management Plan (ISWRMP) applies to all members of Metro, including White Rock. This plan identifies goals for waste reduction and waste diversion and is due for updating over the next two to three years.

White Rock is in the middle of the pack in terms of residential waste diversion and has successful recycling and green waste programs. The limit of garbage collection to two containers every two weeks helps divert materials to recycling and green waste. Further garbage limits along with education from Metro and White Rock could potentially lead to increased residential waste diversion, but may not be popular with residents.

Diversion in the multi-family and commercial sectors of White Rock and throughout Metro is not as successful as in the residential sector. This is due to the complexity of collecting materials from these sectors and the lack of individual accountability for waste. Further improvements are needed in these sectors.

The City recently initiated a detailed waste study that started with a waste audit. This will be followed by public consultation in January and a follow up report to Council. The goals of the study include identifying means to increase waste reduction and diversion in all sectors, increase efficiencies, reduce trucking noise and irritation, and to reduce greenhouse gas emissions due to excess trucking.

Greener Homes

Although White Rock is not in a position to directly influence the construction of greener, more energy efficient homes, the City can support senior government and private sector programs by ensuring that brochures and information are available to builders at the City Permit Counter and participating in programs where feasible. One such program is the Provincial Clean BC Better Homes Rebate Program (Better Homes Program) attached as Appendix B.

The Better Homes Program provides rebates to homeowners who convert from fossil fuel heating systems to electric air-source heat pumps for home and hot water heating. Additional rebates are available for electric service upgrades and EnerGuide home evaluations. Local governments can apply by March 1, 2020 for the next program intake on April 1, 2020. It is recommended that Council consider a late addition of \$15,000 to the Financial Plan for

participation in this top up program and assist the Better Homes Program in communicating ways home owners can participate.

Additionally, the City could make Bylaw changes to reduce the lot coverage of new homes and continue to endorse the enforcement of Bylaws regarding new encroachments on boulevards. These two measures will secure more greenspace for trees and grass.

Community Gardens

White Rock can continue to provide space for the 60-70 plot Community Garden at Centennial Park. Potentially, if there is demand for more space, there may be room at McCaud Park; although, this would need to be discussed extensively with the public along with other uses for an upgraded Park.

Rooftop or other Strata Community Gardens can be considered as a requirement for development of new multi-family buildings.

Trenchless Technologies

Technology for repairing and replacing underground piping without excavation (trenchless technology) is continually evolving. The City is proactive in specifying and approving various types of trenchless technologies in order to minimize the inconvenience and carbon footprint of conventional methods that involve the removal and replacement of materials.

The storm sewer, sanitary sewer and water mains on Marine Drive east of Memorial Park were recently replaced using trenchless technology. This successful project will result in a Greenhouse Gas (GHG) credit in the annual Provincial Climate Action Revenue Incentive Program (CARIP) reporting.

Water Fountains

Appendix C illustrates the locations of water fountains throughout White Rock. In order to reduce plastics in landfills and oceans it is important to start a “reuse culture” for water bottles. The pressures in the fountains will be increased to provide a good flow for filling reusable water bottles and signage will be attached to the fountains as per Appendix C. Additional ways of communicating using fountains over disposable water bottles will be explored.

Water Conservation and Aquifer Recharge

White Rock sources its drinking water from the Sunnyside Aquifer. Water conservation and aquifer protection are key components of the Aquifer Protection Plan completed in 2018. The June 2018 Corporate Report discussing the Aquifer Protection Plan is attached as Appendix D

Storm Water Discharge

The City’s stormwater is discharged to the ocean via various pipes and watercourses. A draft Integrated Stormwater Master Plan (ITMP) now under review addresses issues of storm water routes and capacities. Although cross connection control measures have reduced fecal coliform counts in the stormwater, further work to reduce grits, oils and other contaminants needs to be done.

Transportation

Translink is the regional transportation authority and takes actions based on the 2014 Vision developed by the Mayors’ Council and the Regional Transportation Strategy (RTS) Strategic Framework adopted in 2013 and currently under review for extension to 2050. The RTS estimated that the most affordable and efficient ways of achieving improved livability,

environmental and economic goals would be to make it possible for half of all trips to be made by walking, cycling and transit by 2045.

The City's Integrated Transportation and Infrastructure Master Plan (ITIMP) is set to start with the first of four public consultation and feedback sessions in early Spring 2020. The desired outcome of the ITIMP is a plan for an integrated transportation network that will efficiently handle a growing community and that considers the Translink mode share target of half of all trips to be made by walking, cycling and transit by 2045.

Council recently endorsed the need to use City boulevard for public purposes. One public use of boulevard space is for sidewalks, separated bike lanes and bus stops. Council endorsement was a first step towards improving the environment through less reliance on vehicles for trips that can be made through more environmentally friendly transport modes.

The ITIMP will also focus on improving the efficiency and safety of those trips that do need to be taken by vehicles through improved roadway geometrics and optimal implementation of traffic control devices.

Electric Vehicle Charging Stations

The City provides seven free electric vehicle (EV) charging ports at the West Beach Parkade. There is also one public port at the Ocean Promenade Hotel, although it is configured for Tesla cars only. There are approximately 25-50 additional private and public ports nearby in South Surrey.

Staff will be researching funding opportunities and developing a plan to add EV stations to all City parking facilities. As a first step, the City could consider including additional vehicle charging stations, funded from Climate Action Revenue Incentive Program (CARIP) grants into the 2020 – 2024 Financial Plan. Each electric vehicle charging station with two ports costs approximately \$20,000. Staff will research further and develop short and long-term proposals for electric vehicle charging stations for Council approval.

Tree Canopy

Large tall trees provide a canopy that shades and cools City streets. The trees also hold storm water and release it through evapotranspiration and provide stability to slopes. Together with walkways, large trees provide a pleasant environment where people can travel on foot and socialize with their neighbours rather than using cars.

Council recently directed staff to continue to administer the Street and Traffic Bylaw with respect to new encroachments as well as at the time of property redevelopment. Over time, this will return boulevard space to the City for trees and other uses that will help address climate change. This initiative, as with other environmental initiatives, does not come without "pain" as many affected property owners appeal to be excluded from the Bylaw.

BUDGET IMPLICATIONS

Council may wish to consider including \$15,000, funded an operating reserve or the City's accumulated surplus, to top up the Better Homes Program. Council may also wish to consider including \$20,000, funded from CARIP grants to cover the installation of one new electric vehicle charging station with two ports. Signage for existing water fountains can be incorporated into the Parks Operational budget.

RISK MANAGEMENT

Failure to take basic first steps towards local climate action in White Rock will result in a less environmentally sustainable City for future residents.

CONCLUSION

Further to previous aspirational City environmental plans, the City instituted measures and installed facilities to further environmental sustainability over the past ten years. There are additional next step measures provided in this corporate report that staff will be pursuing as well as items for Council consideration for inclusion in the 2020 – 2024 Financial Plan.

Respectfully submitted,



Jim Gordon
Director, Engineering and Municipal Operations Department

Comments from the Chief Administrative Officer:

I concur with the recommendations of this corporate report.



Dan Bottrill
Chief Administrative Officer

- Appendix A: Letter received September 27, 2019 from K. Blair
- Appendix B: Provincial Clean BC Better Homes Rebate Program (Better Homes Program)
- Appendix C: Locations of water fountains throughout White Rock
- Appendix D: Corporate report dated June 19, 2018 titled “Aquifer Protection Plan”

SEP 27 2019

Dear White Rock city council,

CITY OF WHITE ROCK
ADMINISTRATION

We are holding this protest today to make clear how crucial it is for us to take action for the climate crisis. Our future is in jeopardy. We have made a list of some ways the city of White Rock could become more environmentally friendly. Although White Rock is small we can make a difference. Therefore we would love if you could consider the following ways we have thought of to help save our home.

- **Creating less waste**
Approximately 1400 kilograms of waste is created per person every year in metro vancouver. This is too much! One day we want to live in a world where 0 kilograms of waste is created in the entire world each year! That dream starts here. Some super easy ways to create less waste are **phasing out single use plastic**, and **encouraging people to bring their own commonly used items**, and we should be **encouraging people and businesses to try their best to reduce the amount of waste they create!**
- **Produce less Co2 emissions**
Carbon Dioxide is one main greenhouse gases polluting our planet. Some ways to reduce the amount of Co2 we produce could be creating a **bike sharing system** similar to the one in Vancouver, make more **electric charging stations** for people with electric cars, and **encourage people to take less carbon emitting modes of transportation if possible.**
- **Greener homes**
Having greener homes could be very beneficial and quite easy to do! Installing **solar panels** in homes, especially new homes being built, solar panels give us a natural, more energy efficient source of energy as well as saving money. We should also be trying our best to **save water, compost and recycle, grow our own gardens**, among other things. We could also make more **community gardens** for those who don't have the space to grow their own.
- **Education**
Doing all the things mentioned above is great but one thing that we really need to do is educate our citizens. The climate crisis is real and now is the time to act. We could hold **conferences** at schools in white rock to educate everyone on climate change. Although it is a very popular subject not everyone understands what is really happening. These conferences would give us a chance to learn more about the situation as well as giving the town a chance to come together and create a plan to tackle the climate crisis.

Thank you so much for your consideration. Hopefully some of these dreams can become a reality.

Municipal Top-Up Opportunity CleanBC Better Homes Rebate Program

What is the Better Homes rebate program?

The goal of the CleanBC Better Homes program is to accelerate retrofits that help households reduce greenhouse gas emissions (GHGs) and energy use by providing incentives for high efficiency heating equipment and building envelope improvements. The program offers rebates on these upgrades with a focus on fuel switching from fossil fuel heating systems to high efficiency air-source heat pumps. When visiting the betterhomesbc.ca website, the homeowner is asked to identify which municipality they live in and how they currently heat their home. They are then presented with all the available rebates in their area, including the associated municipal top-ups.

What are municipal top-ups?

Municipal top-ups are additional financial incentives on fuel switch heat pump and EnerGuide assessment rebates. Because our GHG reduction goals align with many municipalities in B.C., we offer municipalities the opportunity to top-up our rebates in order to encourage further uptake in their area. For example, the City of Victoria currently has a \$350 top-up rebate for homeowners who switch from a fossil fuel heating system to an air-source heat pump. A homeowner in Victoria that applies for a CleanBC Better Homes heat pump rebate will receive a \$3,000 rebate from the province, as well as a \$350 top-up from the municipality, for a total rebate of \$3,350.

How are municipal top-ups financed and reported?

The municipal top-up offer is designed so that a municipality can commit a set amount of total funding and choose the municipal top-ups they wish to participate in. The current top up offers by other municipalities can be seen below. You can also visit the Better Homes website to view the current offers available.

Municipal top-ups are accessed and paid out through the general program application and processing team. Top-ups that have been issued for each municipality are tracked. The program team reports to the municipalities quarterly on the number of top-ups claimed, and an invoice is supplied for those top-ups. If no top-ups are accessed, no invoice is sent.

Municipal Top-ups	Vancouver	Victoria	Saanich	Capital Reg. District	Comox Valley	Campbell River	Powell River	Richmond	North Vancouver	Whistler	Kamloops	Kelowna
Fuel Switch Heat Pump												
\$350		\$350	\$350	\$350	\$350	\$350	\$350					
\$2,000	\$2,000								\$2,000	\$2,000		
\$6,000	\$6,000											
EnerGuide Home Evaluation												
\$150	\$150		\$150		\$150	\$150		\$150	\$150		\$150	\$150
Electric Service Upgrade												
\$500	\$500		\$500				\$500		\$500	\$500		
Heat Pump Water Heater												
\$350			\$350				\$350					
\$1,000	\$1,000								\$1,000	\$1,000		
Contractor Spiff												
\$50			\$50						\$50	\$50		
\$300	\$300											

What Top-Ups are available to participate in?

Fuel Switch Heat Pump

The Fuel Switch Heat Pump Top-up is an added rebate for participants that switch from a fossil fuel (oil, natural gas, or propane) heating system to an electric air-source heat-pump. Municipalities can commit to a \$350 or \$2,000 top-up. Participants can either install a fully electric heat pump system or can install a dual-fuel heat pump system with back up fossil fuel heating (i.e. a furnace). The \$6,000 top-up

introduced by the City of Vancouver is an all electric top-up for constituents who remove their gas heated equipment completely. This municipal offer is in addition to the up to \$3,000 Heat Pump rebates currently available through the Better Homes program.

EnerGuide Home Evaluation

The EnerGuide Home Evaluation Top-up is an added rebate of \$150 top-up for participants that complete a pre- and post-retrofit EnerGuide home evaluation. This municipal top-up offer is in addition to the \$300 EnerGuide Home Evaluation rebate currently available through the Better Homes program.

Electric Service Upgrade

The Electric Service Upgrade Top-up is an additional rebate of \$500 for participants upgrading their electrical service to 100, 200 or 400 amp service and switching from a fossil fuel (oil, natural gas, or propane) space or water heating system to an electric air-source heat pump or heat pump water heater. This municipal top-up offer is in addition to the heat pump and electric service upgrade rebates currently available through the Better Homes program.

Heat Pump Water Heater

The Heat Pump Water Heater Top-up is a \$350 or \$1,000 top-up available for participants that switch from a fossil fuel (oil, natural gas, or propane) water heating system to an electric heat pump water heater. This municipal top-up offer is in addition to the \$1,000 heat pump water heater rebate currently available through the Better Homes program.

Contractor Participation Incentive

The Contractor Participation Incentive is a \$50 or \$300 top-up available to the contractor for installing a qualifying heat pump for space or domestic hot water heating in homes that are fuel switching from natural gas, oil, or propane. Contractors are a key stakeholder in the rebate process; 60% of rebate applicants hear about the program from their contractor. The contractor also supports homeowners with required paperwork and the application process. This municipal top-up offer is in addition to the \$50 Contractor Participation Incentive currently available through the Better Homes program.

When can a municipality join the CleanBC Better Homes Municipal Top-up program?

If your municipality is interested in becoming involved in the municipal top-up offer, or would like additional information, please contact Grant Moonie at grant.moonie@gov.bc.ca or (778)698-5381. We can set up a time to talk and discuss steps to be taken to ensure inclusion for 2020. Our next program intake is April 1, 2020. To be included in the program in April, we require notification by March 1, 2020.

The CleanBC Better Homes program works closely with partnering municipalities and supports the program with marketing and promotion specific to the municipalities' region. We are encouraged by municipalities' work to create a clean and energy efficient British Columbia and hope to meet our program goals through successful program partnerships and participation.

Kind Regards,

Grant Moonie | Senior Energy Efficiency Coordinator - Residential
BC Ministry of Energy, Mines and Petroleum Resources
Phone: (778) 698-5381

**Go beyond
the bottle.
Help reduce
plastics in
our oceans.**



**FILL YOUR REUSABLE WATER
CONTAINER HERE.**

*Please note that water pressure at
this fountain has been increased.*

Go beyond the bottle. Help reduce plastics in our oceans.



Fill your reusable water container at these available water stations around White Rock.

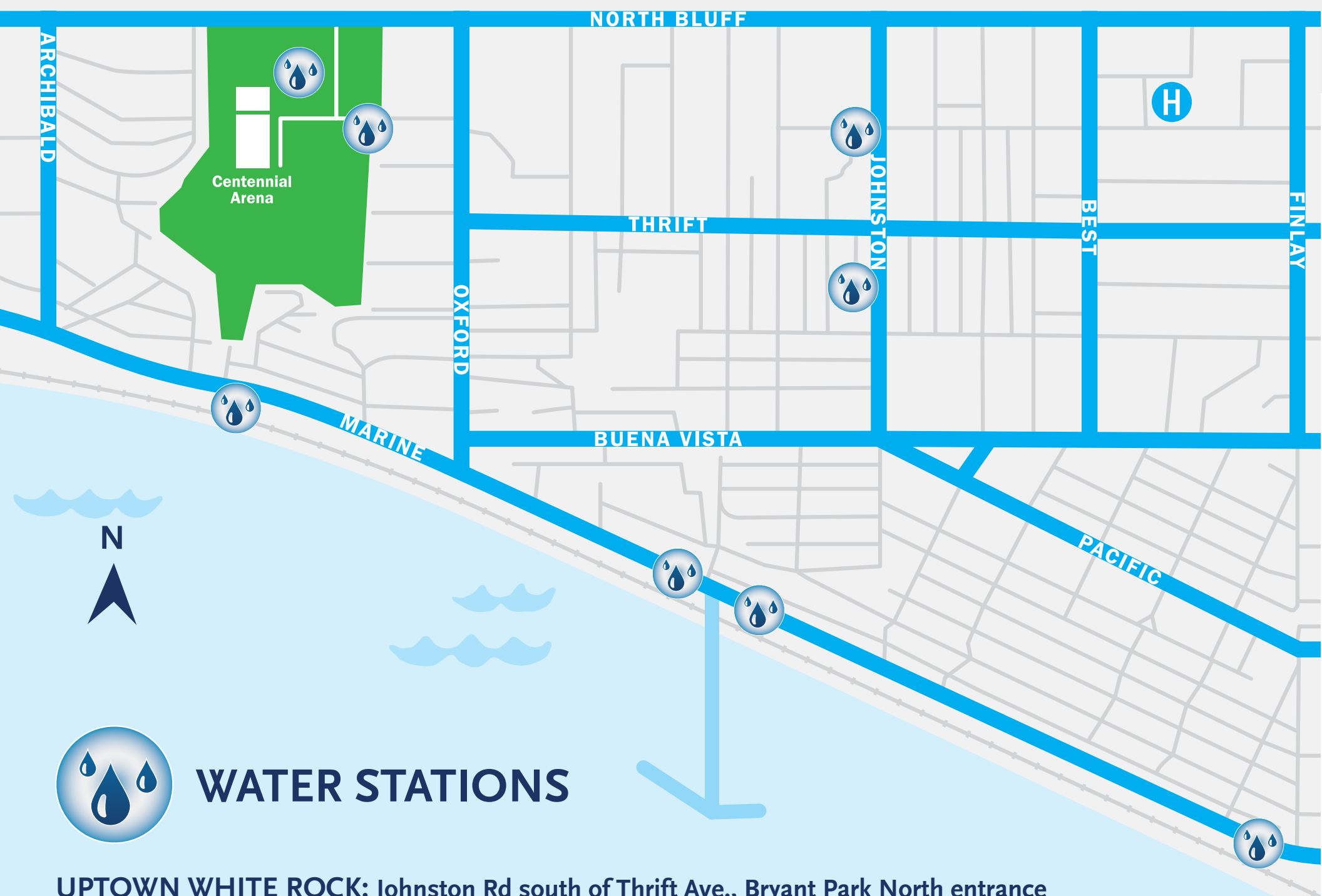

UPTOWN WHITE ROCK: Johnston Rd south of Thrift Ave., Bryant Park North entrance

CENTENNIAL PARK: Lacrosse Courts, Tennis Courts, Generations Playground, and the Off-Leash Dog Park

WATERFRONT PROMENADE: Bayview Park, Memorial Park, East of the Pier, and East Beach

GO BEYOND THE BOTTLE. Help reduce plastics in our oceans.



Fill your reusable water container at these available water stations around White Rock.

 **UPTOWN WHITE ROCK:**
Johnston Rd south of Thrift Ave., and Bryant Park North entrance.

 **CENTENNIAL PARK:**
Lacrosse Courts, Tennis Courts, Generations Playground, and the Off-Leash Dog Park.

 **WATERFRONT PROMENADE:**
Bayview Park, Memorial Park, East of the Pier, and East Beach promenade entrance.

THE CORPORATION OF THE
CITY OF WHITE ROCK
CORPORATE REPORT

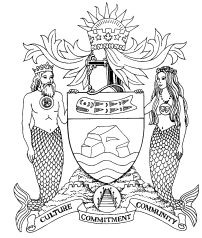

DATE: June 19, 2018
TO: Mayor and Council
FROM: Jim Gordon, P.Eng, Director of Engineering & Municipal Operations
SUBJECT: Aquifer Protection Plan

RECOMMENDATIONS

THAT Council:

1. Receive for information the corporate report dated June 19,2018 from the Director of Engineering & Municipal Operations, titled “Aquifer Protection Plan;” and
 2. Endorse the Aquifer Protection Plan attached to this Corporate Report.
-

INTRODUCTION

The White Rock water supply system relies on groundwater from the Sunnyside Aquifer. Stresses associated with population growth, climate change, sea level rise, and other users of the aquifer have the potential to put increasing pressure on the water supply system.

The Aquifer Protection Plan (Plan) was prepared by Advisian to:

- improve the understanding of the Sunnyside Aquifer;
- evaluate the sustainability of future groundwater use; and
- develop a management framework for the protection of groundwater.

The Plan is a source water protection document. Source water protection is one of the barriers in the multi-barrier approach to drinking water protection.

PAST PRACTICE / POLICY / LEGISLATION

The Plan is the first source water protection document prepared for the City. The Plan can be used to inform land-use planning, to support water management initiatives, and to promote environmental stewardship programs (e.g. residential hazardous waste collection).

ANALYSIS

A brief overview of the Sunnyside Aquifer characteristics, the modeling conducted to evaluate aquifer sustainability, and the general groundwater management framework presented in the Plan is provided below. Technical experts and government authorities with interest/jurisdiction in the study area were invited to participate in a technical working group to support development of the Plan. Information on the Plan is also provided on the City’s website to keep the community

informed (<https://www.whiterockcity.ca/EN/main/city/my-water/city-water-projects/aquifer-protection-plan.html>).

The Sunnyside Aquifer is located in the Surrey Uplands and extends beyond the municipal boundary of the City. Aquifer material is inferred to be glaciofluvial sands and gravels deposited during the Semiahmoo glaciation. The aquifer has a low vulnerability to surface contamination because of natural protection provided by overlying marine sediments and till. Recharge to the aquifer is conceptualized to occur from precipitation that infiltrates into the subsurface and lateral inflow from the east. Limited information was available to determine the extent of surface-groundwater connections.

A numerical groundwater flow model was used to delineate well protection areas and to evaluate aquifer sustainability. Model scenarios to evaluate aquifer sustainability accounted for future water demand based on population growth and land-use changes, increases in water demand due to climate change based on warmer and dryer summer projections, and groundwater extraction planned by the City of Surrey from two existing wells located at Sunnyside Acres Park (24 Ave and 146 St, Surrey). Modeling results suggest future groundwater use is sustainable based on a review of simulated water levels, drawdown, and water balance components.

The groundwater management framework provided in the Plan identifies roles and responsibilities, measures to protect groundwater, mechanisms for funding, as well as performance monitoring and reporting to support adaptive management. Additional details are provided in the Risk Management section of this corporate report.

BUDGET IMPLICATIONS

There are no budget implications.

RISK MANAGEMENT

A risk assessment of potential groundwater hazards was conducted to identify and prioritize action items for groundwater protection in addition to measures already implemented by the City (e.g. water restrictions, water metering). A total of 24 potential groundwater hazards were identified which could affect quality and/or quantity aspects of the water supply source. None of these were considered to be a high risk.

Groundwater hazards associated with groundwater quality (e.g. agricultural land use to the east, saltwater intrusion/upconing, dry cleaning business, and winter maintenance routes) have been assessed as low to moderate risk. Groundwater hazards for groundwater quantity (e.g. future water use by the City of Surrey, uncertainty in regional inflows from the east, water use inefficiencies) have primarily been assigned as moderate risks. The Aquifer Protection Plan attached to this report outlines key actions to mitigate potential risk.

CONCLUSION

The Plan has been prepared as a source water protection document for the City's water supply system as part of a multi-barrier approach to drinking water protection. The Plan provides a total of 15 key actions that can be implemented by the City for groundwater protection based on the current understanding of the Sunnyside Aquifer and predictive groundwater flow modeling results.

A broader, regional approach for aquifer protection is recommended given that the aquifer and well protection areas extend beyond the municipal boundaries of the City. Collaboration with the

City of Surrey and regional approaches for groundwater protection are necessary to avoid fragmented decision-making.

Respectfully submitted,

A handwritten signature in black ink, appearing to read 'Jim Gordon', written over a light grey rectangular background.

Jim Gordon, P.Eng.,
Director of Engineering & Municipal Operations

Comments from the Chief Administrative Officer:

I concur with the recommendations of this corporate report.

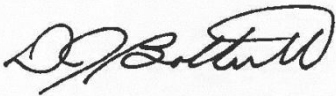
A handwritten signature in black ink, appearing to read 'Dan Bottrill', written over a light grey rectangular background.

Dan Bottrill
Chief Administrative Officer

THE CORPORATION OF THE
CITY OF WHITE ROCK
CORPORATE REPORT

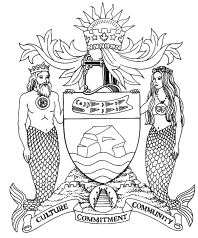

DATE: January 13, 2020
TO: Mayor and Council
FROM: Jim Gordon, P.Eng., Director of Engineering and Municipal Operations
SUBJECT: City Hall – Seismic Report - 2020

RECOMMENDATIONS

THAT Council:

1. Receive for information the corporate report dated January 13, 2020 from the Director of Engineering and Municipal Operations titled “City Hall – Seismic Report - 2020”;
 2. Endorse the retention of a consultant to evaluate options for the future of White Rock City Hall; and
 3. Endorse the development of a 5-year implementation plan for the future of White Rock City Hall as well as the civic precinct.
-

INTRODUCTION

White Rock City Hall was originally constructed in 1962. The building was not designed to withstand a 100-year return period earthquake. The City retained Bush, Bohlman & Partners LLP (BBP) to conduct a seismic assessment, a cost estimate for retrofit, and a retrofit report for White Rock City Hall. The report is attached as Appendix A. The purpose of this corporate report is to summarize BBP’s findings and present options for the future of White Rock City Hall.

PAST PRACTICE / POLICY / LEGISLATION

In British Columbia, new buildings are designed to the 2018 BC Building Code to withstand ground motion with a 2,475-year return period.

ANALYSIS

BBP reviewed the building’s existing structural systems, and assessed the building using the Seismic Retrofit Guidelines Third Edition (SRG3) and the BC Building Code 2018. BBP’s assessment did not include a geotechnical subsurface investigation or a non-structural seismic assessment.

White Rock City Hall is an 11,908-sq.ft building, separated into three areas:

- West Wing - the seismic system for the West Wing consists of unreinforced masonry walls on three sides, and nonductile concrete columns on the west side.

- East Wing - at the East Wing, the seismic systems include unreinforced masonry walls on three sides and nonductile concrete columns on the south side.
- Lobby - the lobby does not have a seismic system; it shares the systems with the two adjacent wings.

BBP's seismic assessment found seismic deficiencies in the following locations:

1. South and west lateral systems are very weak and nonductile, posing a high risk of major damage in a moderate earthquake
2. The masonry walls are unreinforced and risk collapse out of plane.
3. The east wing roof diaphragm is very weak and is not able to properly transfer seismic demands to the lateral system
4. The lobby roof is not connected to a lateral system in the east-west direction, potentially causing failure to the masonry walls
5. The basement is not designed to resist dynamic soil pressures

The consultant found the Probability of Drift Exceedance (PDE) for the concrete frame was 20% in 50 years. Based on the Seismic Retrofit Guidelines, White Rock City Hall is a High Risk (High 1) building. Furthermore, the building only meets 20% of the required lateral capacity of the latest building code (2018 BCBC). Unlike new buildings which are designed to withstand ground motion for a 2,475-year return period earthquake, the White Rock City Hall building could fail from the ground motion predicted for a 100-year return period earthquake.

In addition to seismic deficiencies, the City Hall building does not meet the growing needs of the residents and staff. The building does not have an elevator. A person with mobility challenges needs to walk around the exterior of the building to access another floor. The building also does not house all City staff; Human Resources, Information Technology, Bylaws, Parking and Engineering staff are in a separate buildings. Visitors seeking to do business with other City departments may need commute to a separate building. As the demand for City services increases, the number of City staff will increase. The building does not have space to accommodate additional office space to house new staff.

In a 2010-2011 space planning analysis by MKT Development Group consultants estimated that 26,592-sq.ft of office space is required for accommodating Corporate Administration, Council, Information Technology, Human Resources, Planning and Development Services, and Financial Services staff. Unfortunately, the analysis failed to consider that Senior Engineering staff and Engineering development staff currently at the Operations Yard should be relocated to City Hall requiring an additional 5,475-sq.ft of office space. Therefore, a minimum combined total of 32,000-sq.ft of office space is necessary.

RISK MANAGEMENT

SRG3 is used by the Ministry of Education to determine seismic risk and retrofit requirements. For comparison, the public school system in BC currently has 27% of its schools in high seismic zones rated at the High 1 Risk level. All of these, and any other schools with a PDE rating of 5% in 50 years or greater, will eventually be retrofitted or replaced, but not all at once. The School Seismic Program has been going on for 15 years and will still take many years to complete.

The City Hall building is rated as High 1. If the building is not seismically retrofitted, the building could fail in a 100-year return period earthquake. There are also financial risks to

seismically retrofitting City Hall because additional space would be necessary to accommodate accessibility requirements and office space for staff.

OPTIONS

Given the growing needs of the City, seismically retrofitting City Hall may not offer the best value. Staff have considered several options for the future of City Hall. These options are listed as follows:

- 1) Seismic retrofit of City Hall to less than 2% PDE per SRG3
- 2) Partial seismic retrofit of City Hall to High 2 (7% to 10% PDE) per SRG3
- 3) Rent office space and relocate City Hall to a commercial building
- 4) Partnerships with other institutions to develop a new City Hall
- 5) Relocate staff to other City-owned buildings (ie: Evergreen Daycare)
- 6) Construct a new City Hall

Option 1 – Seismic Retrofit

A retrofit is estimated to cost \$1.8M and at least 9 months to complete, if the building is unoccupied during renovation. This retrofit will address life safety issues in the event of a major earthquake; but the building could be extensively damaged beyond repair. This retrofit could potentially protect the building against less severe earthquakes. The cost estimate for a retrofit excludes staff relocation and office space rental. If the building is to remain occupied during retrofit, additional budget and time would be necessary.

Option 2 – Partial Seismic Retrofit

Costs for an interim partial retrofit to a lower standard (High 2) are not currently available.

Option 3 – Rent Commercial Office Space

Commercial office space vacancy is low in White Rock. The estimated commercial rental rate for the South Surrey and White Rock area is between \$14/sq.ft and \$30/sq.ft per annum. The challenge is finding a location that provides 32,000-sq.ft. of office space to house all City staff.

Assuming a 32,000-sq.ft facility is available, the present value (PV) of this option is determined using the growing annuity formula as shown in Appendix B. At a 50 year term (based on the typical design useful life of a civic building), the present value of this option is \$24.9M at rents of \$14/sq.ft and \$124.7M at rents of \$30/sq.ft. These costs do not include the fitting of the rental space with offices, IT, etc..

Option 4 – Partnerships with Other Institutions to Develop a New City Hall

This option involves working with a developer to incorporate commercial space within a multi-use building. Similar to the White Rock Community Centre, the commercial space would be in a separate commercial strata. The City would purchase the commercial strata at market value less the value of development's Community Amenity Contribution (CAC). For example, if the market value of the commercial strata is \$25M and the development site's CAC is \$5M, the City's cost would be \$20M.

Option 5 – Relocate Staff to Other City-Owned Buildings

This option involves relocating some City staff to other City-owned buildings in the Civic Block (ie: Library or Evergreen Daycare). The costs of this option is currently not available as seismic assessments would be required for the Library or the Evergreen Daycare building. This option would displace the current users of these civic buildings.

Option 6 – Construct a New City Hall

A very rough estimate for the construction of a new City Hall is approximately \$25 M. This cost estimate is for a basic office building, excluding the premium furnishings of typical civic buildings (ie: atrium, art, or Council chambers).

BUDGET IMPLICATIONS

There is currently \$50,000 in the Financial Plan to develop options that could be used for detailed feasibility investigations. The 2020 to 2024 Financial Plan, subject to Council approval, includes \$1.5M in each of the next two years for a “City Hall Project”.

RECOMMENDATION

Staff recommends that a consultant be retained to develop, evaluate and assess the feasibility of the options for the future of City Hall, including the options listed above. Furthermore, Staff recommends that Council endorse the development of a 5 year implementation plan for the future of City Hall as well as the civic precinct.

CONCLUSION

The City retained Bush, Bohlman & Partners LLP (BBP) to conduct a seismic assessment, a cost estimate for retrofit, and a retrofit report. New buildings are designed to the 2018 BC Building Code to withstand a ground motion with a 2,475-year return period.

Based on the Seismic Retrofit Guidelines, White Rock City Hall is a High Risk (High 1) building and only meets 20% of the required lateral capacity of the latest building code (2018 BCBC). The building could fail from the ground motion predicted for a 100-year return period earthquake. A seismic retrofit is estimated to cost \$1.8M and at least 9 months to complete if the building is unoccupied. This retrofit does not address the accessibility issues of the building nor the need for more office space to house City staff.

Given the growing needs of the City, seismically retrofitting City Hall may not offer the best value. It is recommended that a consultant be retained to develop options and provide a feasibility study for the future of City Hall and a 5-year implementation plan that would include the civic precinct.

Respectfully submitted,



Jim Gordon, P.Eng.
Director of Engineering and Municipal Operations

Comments from the Chief Administrative Officer:

I concur with the recommendations of this corporate report.

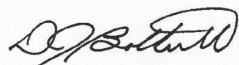

Dan Bottrill
Chief Administrative Officer

Appendix A: DRAFT Bush, Bohlman & Partners LLP report titled “White Rock City Hall Seismic Assessment and Retrofit Report”

Appendix B: Present Value of Renting Commercial Office Space

December 6, 2019

White Rock City Hall

Seismic Assessment and Retrofit Report

**BUSH, BOHLMAN
& PARTNERS LLP**

Draft

Project Number: 7756
Submission by: Tim White, PhD, PEng, Partner
1550 - 1500 West Georgia Street
Vancouver, BC V6G 2Z6
Tel: 604-688-9861 www.bushbohlman.com

Submission to: Rosaline Choy, PEng, MBA, LEED
Manager of Engineering, City of White Rock
15322 Buena Vista Avenue, White Rock, BC V4B 1Y6

TABLE OF CONTENTS

EXECUTIVE SUMMARY 3

INTRODUCTION..... 3

DESCRIPTION OF BUILDING 4

 West Wing..... 5

 East Wing 6

 Lobby..... 6

 Masonry Walls 6

GEOTECHNICAL INVESTIGATION..... 7

REVIEW OF PREVIOUS SEISMIC ASSESSMENT 7

SEISMIC ASSESSMENT 7

 Methodology..... 7

 Seismic Assessment Parameters..... 8

 Seismic Assessment Results..... 8

 Seismic Deficiencies 9

SEISMIC RETROFIT SCHEME 9

 Operational Disruptions..... 11

 Cost Estimate 12

 Seismic Retrofit Discussion 12

CONCLUSIONS AND RECOMMENDATIONS..... 12

APPENDIX A..... 14

APPENDIX B..... 15

EXECUTIVE SUMMARY

Structural engineering assessment results indicate that the White Rock City Hall building has an overall rating of High 1 Risk, per Seismic Retrofit Guidelines Third Edition (SRG3) and only meets 20% of the lateral strength requirements of the 2018 British Columbia Building Code (BCBC).

A seismic retrofit scheme has been devised to achieve the Life-Safety Performance Objective of SRG3. This can be achieved by adding new exterior concrete buttress walls, reinforcement of existing unreinforced masonry walls, roof diaphragm upgrades, and improvements to the basement walls. The retrofit would take nine months if the building was unoccupied. The cost for this retrofit is approximately \$1.8 million excluding office rental and moving costs.

To move forward with the retrofit we recommend completing a more detailed cost estimate, a geotechnical sub-surface investigation, and a hazardous materials assessment of the affected parts of the building. Following that, a full consultant team should be engaged to develop design drawings and a phasing plan if the building is to remain occupied during the retrofit.

INTRODUCTION

Bush Bohlman and Partners, LLP (BBP), performed a structural seismic assessment of White Rock City Hall at 15322 Buena Vista Avenue in White Rock, BC. The purpose of this assessment was to update a previous seismic study by BBP, which was completed in August 2013. Specifically, the update was intended to address changes in the seismic provisions of the recent 2018 British Columbia Building Code (BCBC), and provide context on the level of risk to the existing building.

This report includes an evaluation of the seismic load resisting systems of the building and a proposed seismic retrofit scheme with cost estimate. The opinions and recommendation are based on a review of existing drawings, a site visit, and calculations using SRG3, BCBC, and applicable material standards. Our scope of services did not include a geotechnical subsurface investigation or a non-structural seismic assessment.

We visited the facility on October 18, 2019. Our objective was to confirm relevance of available drawings and reports, and to review the condition of the building structure. During our visit we were able to observe representative areas of the building interior and exterior. This review was of a visual nature only and did not include any destructive investigation or x-ray scanning to determine existence or quantity of reinforcement in concrete and masonry elements.

This report includes a description of the existing structural systems, a seismic assessment, a retrofit concept, and a preliminary cost estimate.

DESCRIPTION OF BUILDING

White Rock City Hall was originally constructed in 1962. It is a two-storey structure with flat roofs. The lower level has a basement wall on the north side but exits at grade on the south elevation. Figure 1 below includes a photograph of the main entry area on the north side of the building.



Figure 1: North Elevation of White Rock City Hall

The building can be separated into three distinct portions or “blocks”. Figure 2 provides a key plan of the blocks. These are the West Wing which houses the Council Chambers on the upper level, the East Wing, and the lobby. All three blocks have the same floor elevations at both the lower and upper levels. The West Wing has a higher roof elevation than the East Wing, and the lobby has a lower roof elevation than both East and West Wings.

During our previous study we were provided with copies of the original architectural and structural drawings of the building. The architectural set was prepared by Carlberg Jackson Associates Architects and dated September 1962. This set included drawings A1 through A6. Structural drawings were prepared by C.F. Moore Structural Engineer and also dated September 1962. That set included drawings S1 through S4.

Our site walkthrough on October 18, 2019, confirmed that the main structure had not been significantly altered since original construction. There have been a number of interior renovations, but nothing to the extent that would influence the seismic behaviour of the building.

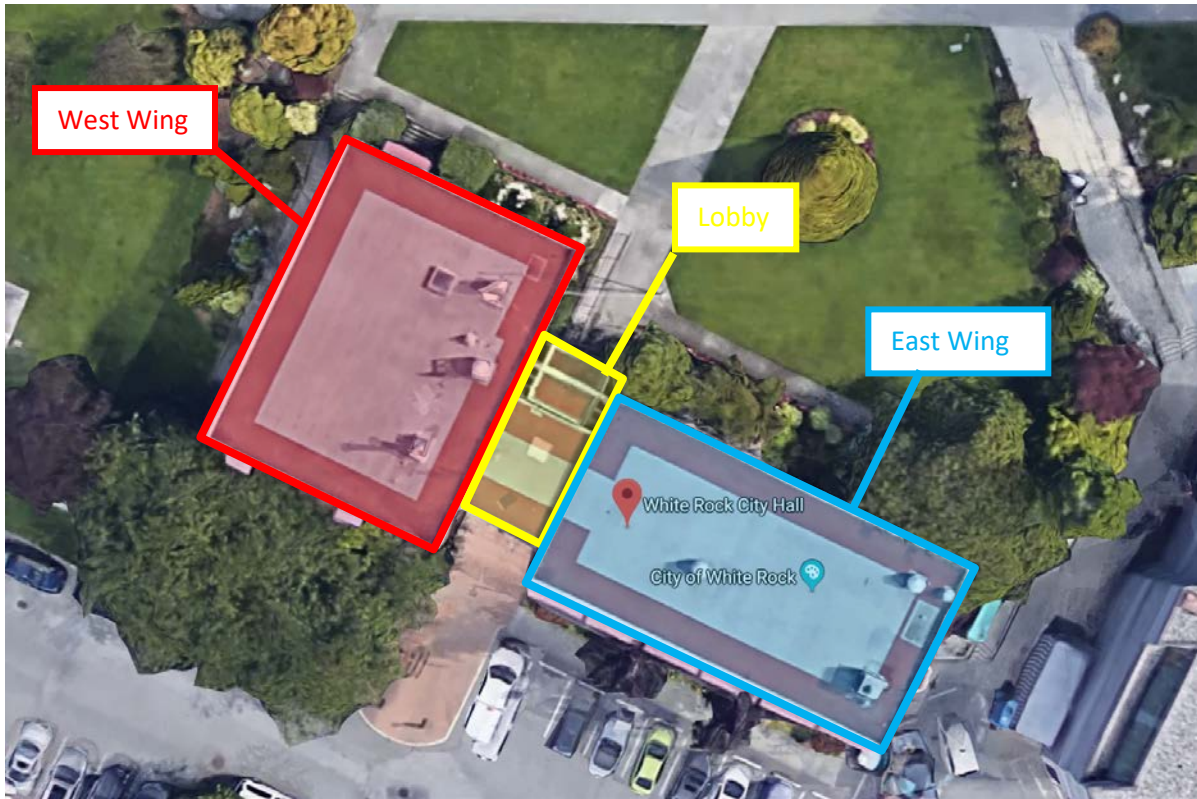

Figure 2: Key Plan of White Rock City Hall

West Wing

The West Wing roof structure consists of 64mm tongue and groove (T&G) timber decking supported by glulam beams at the interior and masonry walls at the exterior. The glulam beams are supported by a combination of steel posts, concrete columns (west elevation), and masonry walls. The suspended floor is plywood and shiplap over timber joists spanning to glulam beams at the interior. On the north side the joists are supported by a concrete basement wall. On the south side they are supported by masonry walls. The glulams, like the upper floor, are supported by a combination of steel posts, concrete columns (west elevation), and masonry walls. The ground floor is slab on grade. The foundation consists of conventional strip and pad footings. Interior partition walls are wood stud, except in the vault (see below) where they are unreinforced masonry.

On the lower level there is a vault in the northeast corner of the west wing. This area has a concrete suspended slab over top (instead of a timber floor) and is supported by masonry walls on the interior sides and concrete walls on the exterior sides. Also, on the lower level, the north walls and northern part of the east exterior walls are concrete basement walls.

The seismic system for the west block consists of unreinforced masonry walls on three sides, and nonductile concrete columns on the west elevation.

East Wing

The east wing roof consists of shiplap on timber joists spanning to glulam beams. Glulam beams are supported by steel posts at the interior and concrete columns at the exterior. At the east and west ends of the east wing, the glulam beams bear on unreinforced masonry walls. The suspended floor is a cast-in-place concrete slab. The slab is supported by concrete beams and columns. The ground floor is slab on grade. Foundations are conventional strip and pad footings. Interior partition walls are mostly wood stud, however there are a number of unreinforced masonry demising walls on the east half of the block. There partial- and full-height concrete basement walls on the north and east exterior elevations.

On the upper floor there is an existing vault room with masonry walls and a concrete slab ceiling which is separate from the main roof framing.

The seismic systems for the east wing are unreinforced masonry walls on three sides and nonductile concrete columns on the south elevation. The roof diaphragm is timber and the suspended floor diaphragm is cast-in-place concrete.

Lobby

The lobby has a T&G roof deck supported by glulam beams. The beams bear on masonry walls on both sides, which are shared with the two wings. The suspended floor is a cast-in-place slab which spans across the width of the block and bears on the two shared masonry walls. Ground floor is slab on grade. There are two sets of stairs, both of which are of suspended concrete construction. Footings are conventional strip and pad footings. Demising walls in this block are either glazing or timber stud walls.

The lobby does not have a seismic system of its own, but shares the systems with the two wings. In the north-south direction it shares the masonry walls of those blocks. In the east-west direction it relies on its connection to the east wing via its floor slab.

There is no seismic gap between the lobby and the two adjacent wings.

Masonry Walls

White Rock City Hall has what looks like clay brick walls on many exterior faces and in portions of the interior. Typical clay brick units have approximate dimensions of 64mm high, 100mm wide, and 200mm long. Walls of this type are present as a load-bearing medium only in pre-WW2 buildings.

Contemporary buildings only use bricks as a non-load bearing veneer. The brick at White Rock City Hall is referred to as "Giant Brick" and is actually a form of load-bearing masonry (i.e., from a structural engineering perspective, we treat it as concrete masonry, not as clay brick). These brick units have dimensions of 64mm high, 200mm wide, and 300mm long. For the most part this masonry is unreinforced, however there are portions supporting beams that have vertical reinforcing added to enhance their load-bearing capacity.

GEOTECHNICAL INVESTIGATION

There were no recent geotechnical reports available to assist in our review. Original structural drawings have indicated that the soil has an allowable bearing pressure of 8000psf (385kPa). Based on our experience with the White Rock area, we have assumed this to be founded on Site Class C materials for the purposes of seismic evaluation.

REVIEW OF PREVIOUS SEISMIC ASSESSMENT

Our previous seismic report of White Rock City Hall was completed in August 2013. The report identified the building as “High” risk and provided capacity-demand ratios based on 2012 BCBC code requirements. A conceptual retrofit scheme was proposed with an order of magnitude costing of \$850,000.

SEISMIC ASSESSMENT

Methodology

BBP performed structural engineering evaluation based on the Seismic Retrofit Guidelines. These are technical procedures developed by The Association of Professional Engineers and Geoscientists of British Columbia (now EGBC) and the University of British Columbia (UBC) for use in the British Columbia Ministry of Education School Seismic Upgrade Program. The guidelines aim to provide a uniform approach for providing life-safety seismic performance of low-rise buildings in a cost-effective manner. The original Seismic Retrofit Guidelines (SRG1) were published in 2011. These were updated and improved in 2013 (SRG2) and again in 2017 (SRG3). Our evaluation is based on SRG3.

Structural elements are evaluated for their ability to continue supporting gravity loads while undergoing horizontal displacements under seismic loading. The guidelines have identified a number of common structural prototypes used within school buildings in British Columbia. For each prototype researchers have established the maximum drift, which is the ratio of an element’s displacement to its height, it can experience without losing load-carrying capacity. The SRG3 evaluates the probability that this drift will be exceeded in a fifty-year period for all types of earthquakes and levels of shaking at a given geographic location. The probability of drift exceedance (PDE) value is used as a measure of risk to the life safety of the building occupants. Relative values of PDE allow the risk to be prioritized. A summary of PDE versus risk ranking is presented below.

$0 \leq \text{PDE} \leq 2.0\%$	No retrofit required
$2.0\% < \text{PDE} \leq 5.0\%$	Medium
$5.0\% < \text{PDE} \leq 7.0\%$	High 3
$7.0\% < \text{PDE} \leq 10.0\%$	High 2
$10\% < \text{PDE}$	High 1

Seismic Assessment Parameters

Below were the governing parameters for the Seismic Retrofit Guidelines (SRG3) assessment:

(SRG3)

Site class:	C
Municipality:	White Rock
LDRS prototypes:	Unreinforced masonry (M-2) Nonductile concrete frame (C-3)
Governing drift limit:	1.25%
Governing LDRS capacity (R_e):	M-2 (27%W) C-3 (6.5%W)
VLS drift capacity:	1.25%
Diaphragm prototype:	Unblocked plywood (D-2) Horizontal boards (D-3)
Diaphragm span:	18.5m and 22.2m
Diaphragm capacity:	9% W_d and 4.5% W_d

In addition to SRG3 analysis, BBP also evaluated the building using the building code. Demands for earthquake loads were determined based on the British Columbia Building Code (BCBC), 2018 edition.

(2018 BCBC)

Site class:	C
SFRS system (R_dR_o):	Conventional Construction (1.5, 1.3)
Importance factor:	1.0
Building period:	0.2 seconds
Spectra accelerations:	0.871g
Base shear demand:	39%W

Seismic Assessment Results

The lateral systems for City Hall are a combination of unreinforced masonry walls and nonductile concrete moment frames. The masonry walls (acting in plane) are long with a relatively small proportion of openings. Thus their capacity is quite reasonable, ranging from 25%W to 45%W based on location and level. The weakest of the group had a PDE=3.0% which is at the low end of Medium. The concrete moment frames are much weaker. Resistance ranged from 6%W to 8%W. PDE was over 20%, which makes these risk level High 1, which is the worst rating under SRG3. From a code perspective the masonry walls are not permitted in high seismic regions, so we are not able to compare them to code. The concrete moment frames only meet about 20% code requirements. An earthquake with a return period of 100 years has seismic demands of only 24% of the full code design requirements. As such the

concrete moment frames would not be expected to be able to resist an earthquake with a 100-year return period.

The timber roof diaphragms have capacity ranging from 4.5%W to 9%W. The lower capacities are High risk, while the higher capacities are Medium risk. This represents a range between 30% and 60% of resistance to BCBC force demands. We have assumed that the T&G decking in the lobby roof and west wing roof are “side-spiked” based on the thickness of the T&G decking. This may need to be verified by pacometer scanning depending on future seismic retrofit plans. The floor diaphragms have much lower seismic demands and higher capacities. The flexible timber floor diaphragm in the West Wing is low risk and 100% code compliant, as are the rigid concrete diaphragms in the lobby and East Wing.

The masonry walls were assessed for their out-of-plane stability. Lower floor walls with lowest demand and highest surcharge had a PDE of 5.1%, which is a risk of High 3. Upper level walls had a PDE of 9.2%, or High 2.

Seismic Deficiencies

The seismic deficiencies for the building are summarized on the next page.

See Appendix A for a plan illustrating the deficiencies.

SEISMIC RETROFIT SCHEME

Given the extensive list of seismic deficiencies for White Rock City Hall, we recommend a seismic retrofit. Given the vintage of the building, in our experience it is not economically feasible to upgrade to be in compliance with the seismic provisions of the building code. We would recommend upgrading using the BC Seismic Retrofit Guidelines for Schools, Third Edition (SRG3). SRG3 was specifically developed to upgrade school buildings, many of which are of similar vintage and construction type to White Rock City Hall.

The level of upgrade we recommend in SRG3 is called the Life-Safety Performance Objective. This level of upgrade has been specifically designed to allow the occupants of the building to exit safely after a large earthquake with a return period of 2,475 years. This is the same seismic hazard as used by the BCBC. After such an event the building would not be repairable, but the Life-Safety upgrade would either mitigate or eliminate damage resulting from lesser earthquakes.

The actual design forces for the new buttress shear walls (based on SRG3) are approximately equal to 65% of the design forces that would be required for a new building by 2018 BCBC.

Table 1: Seismic Deficiencies

Ref #	Element	Description
1	South and west nonductile columns lateral system	The south and west lateral systems are very weak and nonductile. They pose a very high risk of major damage in even a moderate earthquake. We estimate that a 1-in-100-year event could cause this lateral system to fail.
2	Masonry walls	The masonry walls are unreinforced and pose a risk to collapse out of plane. The risk of this is higher on the upper level. The masonry walls also provide lateral resistance for most of the building. In this regard they have reasonable capacity, but are not permitted in new construction and thus are not code compliant. All unreinforced masonry walls in the building are susceptible to out-of-plane failure.
3	Wing roof diaphragms	The East Wing roof diaphragm is very weak and is not able to properly transfer seismic demands to the lateral system, nor adequately restrain the top of the masonry walls. The West Wing roof diaphragm may or may not be High risk. If the T&G decking is "side spiked" then it will be only Medium risk.
4	Lobby roof diaphragm	The lobby roof diaphragm is not connected to a lateral system in the east-west direction and could "pound" into the wings and potentially fail the masonry walls.
5	Basement walls	The basement retains soil on the north side but not the south. The basement is required to resist dynamic soil pressures for which it has not been designed.

SRG3 allows for lower forces levels than the code, as it specifically controls the amount of movement of the seismic elements, and allows them to move as far as possible without degrading dangerously. The code is specifically developed for the design of new buildings, and does not get into much detail on the nonlinear behaviour of different types of seismic systems. The purpose of the code is to provide a robust infrastructure of buildings. SRG was developed to provide affordable yet safe retrofits to existing buildings.

The seismic retrofit scheme with typical details is provided in Appendix B. Table 3 below provides a further description with quantities.

Table 2: Seismic Retrofit Recommendations

Ref #	Element	Description	Quantities
CSW#5	Exterior concrete buttress walls	Provide new external concrete shear walls with soil anchors and steel drag struts.	(2) walls 350mm thick x 1800mm long. West wall is 6.85m tall. East wall is 6.25m tall. Both pile caps 3m x 1.5m x 900mm deep. Each pile cap comes with (4) #14 Dywidag soil anchor.
MW#1	Masonry walls (reinforce at 1200mm o.c.)	Add vertical reinforcing to existing masonry walls. Provide troweled finish with mortar joints. Provide connections to roof and floor diaphragms. Paint entire wall.	3.2m high x 60m 3.0m high x 37.8m 3.65m high x 38.5m
MW#1 Alt	Masonry walls (reinforce at 600 o.c.)	Add vertical reinforcing to existing masonry walls. Provide troweled finish with mortar joints. Provide connections to roof and floor diaphragms. Paint entire wall.	3.2m high x 9m 3.0m high x 6.1m 3.65m high x 4.9m
WD#1	Roof diaphragm upgrades	Remove roofing and resheathe existing deck with new 12.7mm plywood. Provide sheet metal straps around. Reroof.	564m ²
	Steel drag struts	Provide steel drag struts on top of roof or on underside of suspended floors.	Roof: PL102 x 6.4mm x 60m Ceiling: L102x102x6.4 x 60m
SSK#1	Basement wall upgrades	Excavate adjacent to basement wall. Provide horizontal exterior grade beam and vertical piers with footings. Backfill.	Grade beam: 50m long Piers & footing: 4 of each

Operational Disruptions

Construction is extensive and while much of the work can be completed from the outside, a significant portion would have to be completed on the inside. These include:

- Adding vertical reinforcing to masonry walls (not all but a large portion)
- Connections between masonry walls and roofs and floors
- Drag struts attached to the underside of floors

The exterior upgrades do not directly impact the interior space, but will impact building exits and can be very loud.

Our estimate for the duration of construction is nine months, assuming the building is unoccupied. If the building must remain at least partially occupied, a phasing plan will have to be developed in conjunction with an architect.

Cost Estimate

The Ministry of Education has developed unit rate costs for the retrofit of schools based on past projects. The White Rock City Hall is not unlike a small school building. Based on type of construction and location, we estimate the construction cost for the retrofit to be approximately \$1.8 million excluding office rental and moving costs.

A more detailed cost estimate is currently being developed by our Quantity Surveyor, LEC. We will forward their report as soon as it is available.

Seismic Retrofit Discussion

Many building owners are faced with the dilemma as to what is an acceptable level of earthquake risk. We recommend reducing the risk of structural failure down to 2% in 50 years. This is achievable by the life-safety retrofit performance objective in SRG3, and reflected in the retrofit scheme presented in this report. However we recognize that costs to retrofit some buildings are prohibitive, and it often makes sense to relocate or rebuild.

For comparison, the public school system in BC currently has 27% of its schools in high seismic zones rated at the High 1 Risk level. All of these, and any other schools with a PDE rating of 5% in 50 years or greater, will eventually be retrofitted or replaced, but not all at once. The School Seismic Program has been going on for 15 years and will still take many years to complete.

A compromise solution can be to replace the building (often required for reasons not purely seismic) in the future, but in the meantime perform a partial seismic upgrade to significantly reduce the risk without bringing the risk down all the way to 2% in 50 years.

CONCLUSIONS AND RECOMMENDATIONS

The White Rock City Hall is a High Risk (High 1) building as defined by the Seismic Retrofit Guidelines Third Edition (SRG3). Compared to the latest building code (2018 BCBC) it only meets 20% of the required lateral capacity. The predicted level of ground shaking for a 100-year-return-period earthquake could fail the building's seismic-force-resisting system. New buildings are designed to withstand a ground motion with a 2,475-year return period. We highly recommend this building be seismically retrofitted.

The major seismic deficiencies include: a weak and brittle concrete-frame lateral system on the west side of the West Wing and south side of the East Wing, unreinforced masonry "Giant-Brick" walls

throughout, weak roof diaphragms, and unbalanced dynamic earth pressures against the existing basement walls.

Our recommended seismic retrofit would achieve the Life-Safety Performance Objective of SRG3 and includes: new buttress shear walls, reinforcement of existing masonry, roof diaphragm upgrades, and retrofitting of the basement walls. Approximate cost of retrofit is \$1.8 million (excluding office rental and moving costs). A more detailed costing is being prepared by LEC.

If there is a desire to rebuilt or relocate City Hall, a lesser level upgrade can be developed to provide a reduced risk until such time.

Next steps include: developing a more detailed cost estimate, geotechnical site investigation, hazardous materials investigation, and testing the existing roof decking for side-spiking. These will help further define scope of work. Beyond this, a full consultant team would need to be retained to develop design drawings.

If you have any comments or questions, please contact the undersigned.

Yours truly,

Reviewed by,

**Tim White, Ph.D., P.Eng.,
Partner**

**Charlene Hails, P.Eng.
Project Engineer**

APPENDIX A

SEISMIC DEFICIENCIES

- SEISMIC DEFICIENCIES PLAN

#1 - Non-ductile moment frames are very weak and brittle

#4 - Lobby roof diaphragm can "pound" into adjacent masonry walls

#2 - Unreinforced masonry walls. All susceptible to out-of-plane failure

#3 - Weak timber roof diaphragms

#5 - Basement walls must be improved to resist dynamic soil forces

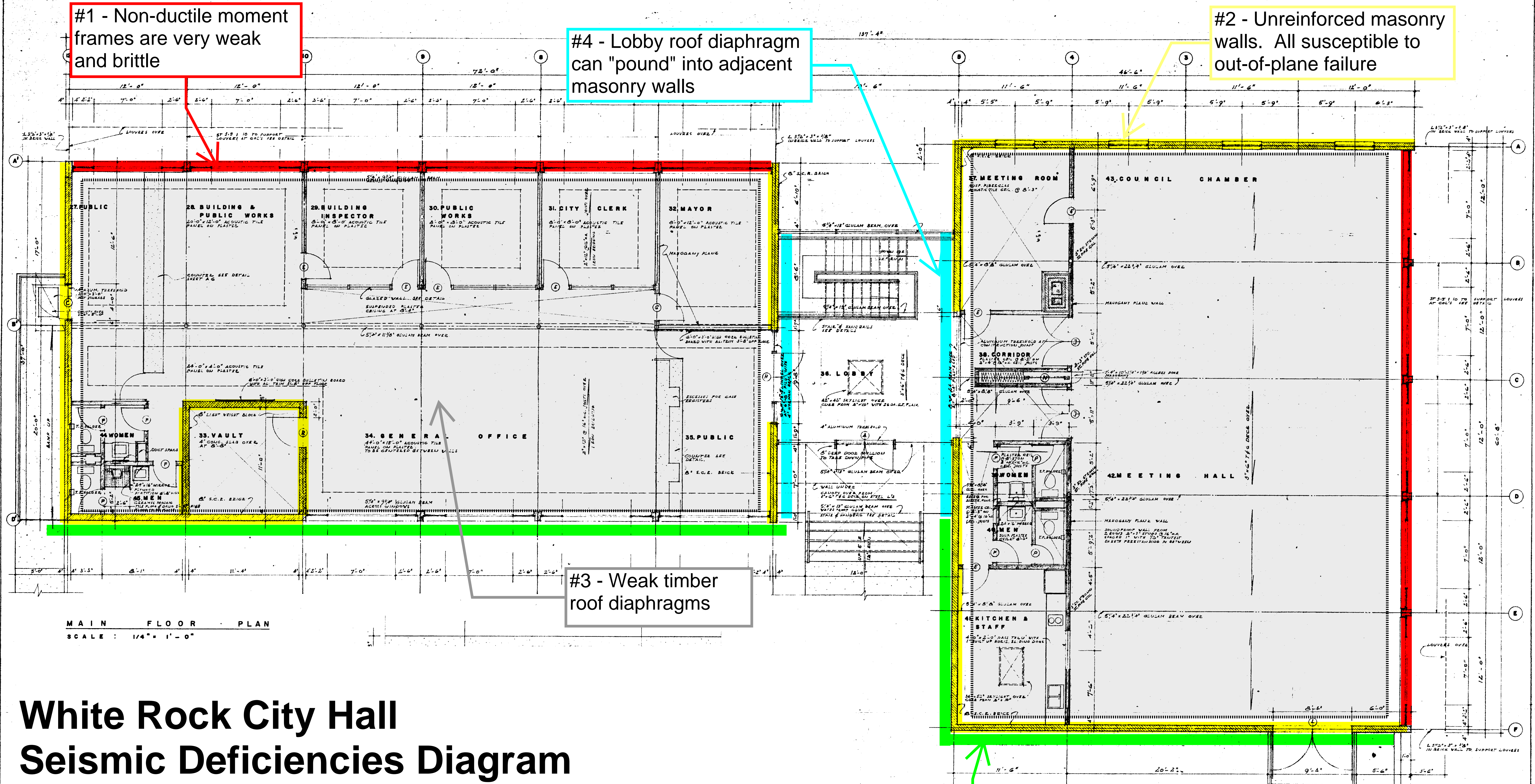

MAIN FLOOR PLAN
SCALE: 1/4" = 1'-0"

White Rock City Hall Seismic Deficiencies Diagram Bush, Bohlman & Partners LLP November 10, 2019

CARLBERG JACKSON ASSOCIATES ARCHITECTS
NEW WESTMINSTER, B.C.
Filename: HALL03

COMM. 0114	DATE 09.19.18	DRAWN U.P.H.	CHECKED D.S.J.	SHEET A3	OF 6
------------	---------------	--------------	----------------	----------	------

APPENDIX B

SEISMIC RETROFIT

- SEISMIC RETROFIT SCHEME
- TYPICAL SEISMIC RETROFIT DETAILS

Steel Drag Strut on roof and under floor

Reinforced concrete buttress wall with micro piles (CSW#5)

Reinforce masonry walls with vertical bars and connect to floor/roof diaphragm. Paint walls. (MW#1)

Remove roofing and sheath roof with new plywood and sheet metal chords (WD#1)

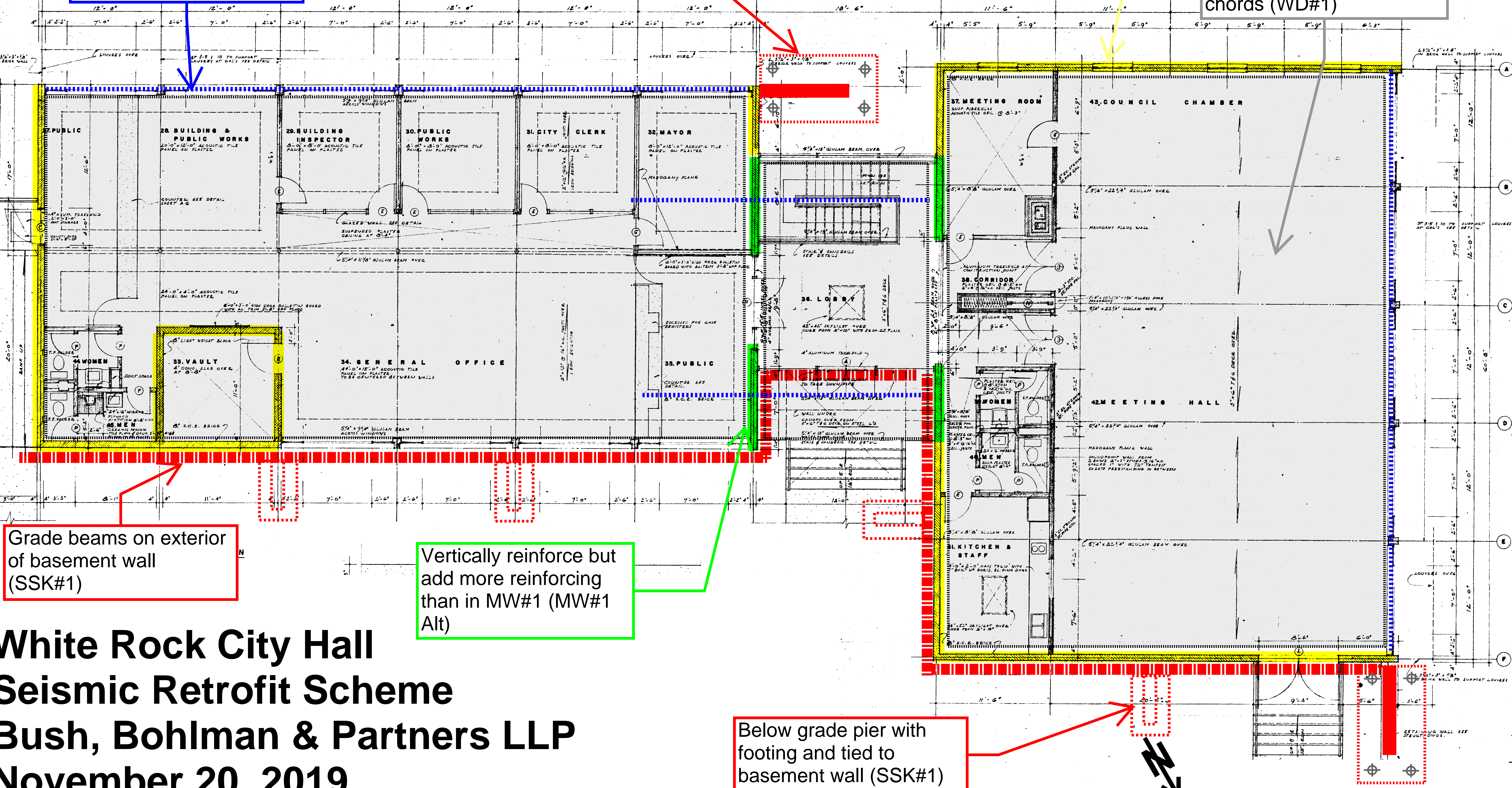

Grade beams on exterior of basement wall (SSK#1)

Vertically reinforce but add more reinforcing than in MW#1 (MW#1 Alt)

Below grade pier with footing and tied to basement wall (SSK#1)

White Rock City Hall Seismic Retrofit Scheme Bush, Bohlman & Partners LLP November 20, 2019

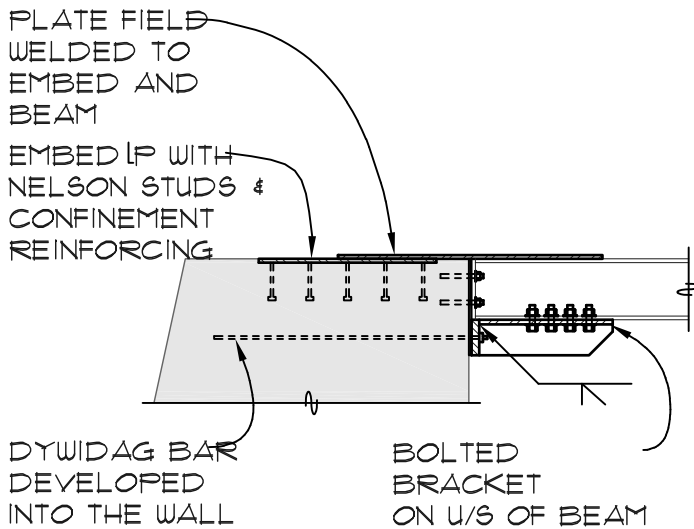

BEAM-TO-BUTTRESS CONNECTION



WALL HORIZONTAL SECTION

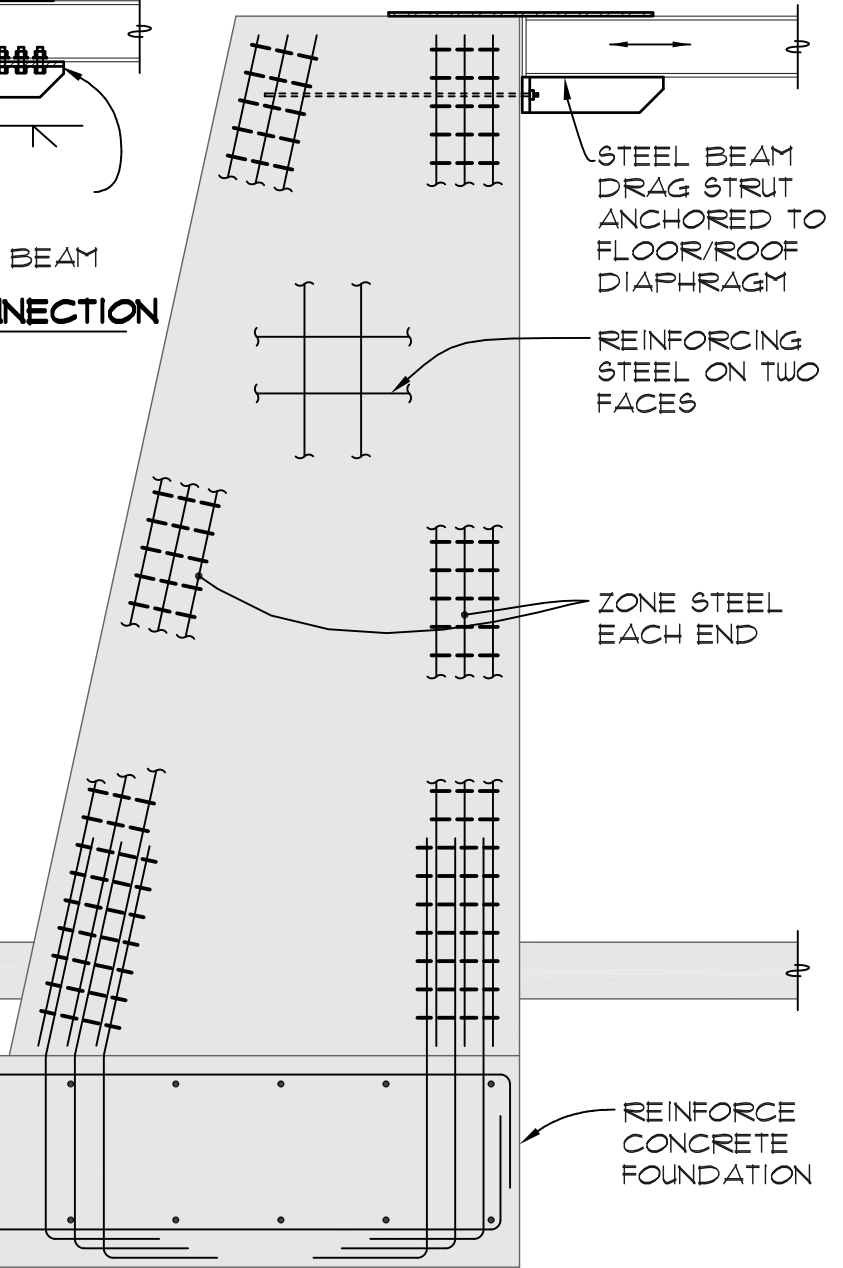

EXTERIOR REINFORCED CONCRETE BUTTRESS

SEISMIC RETROFIT GUIDELINES
 THIRD EDITION
 LIBRARY OF RETROFIT DETAILS
 SEPTEMBER, 2016

CONCRETE SHEARWALL #5
 EXTERIOR BUTTRESS WALL

SCALE
 1:20
 SHEET No.
 CSW
 #5

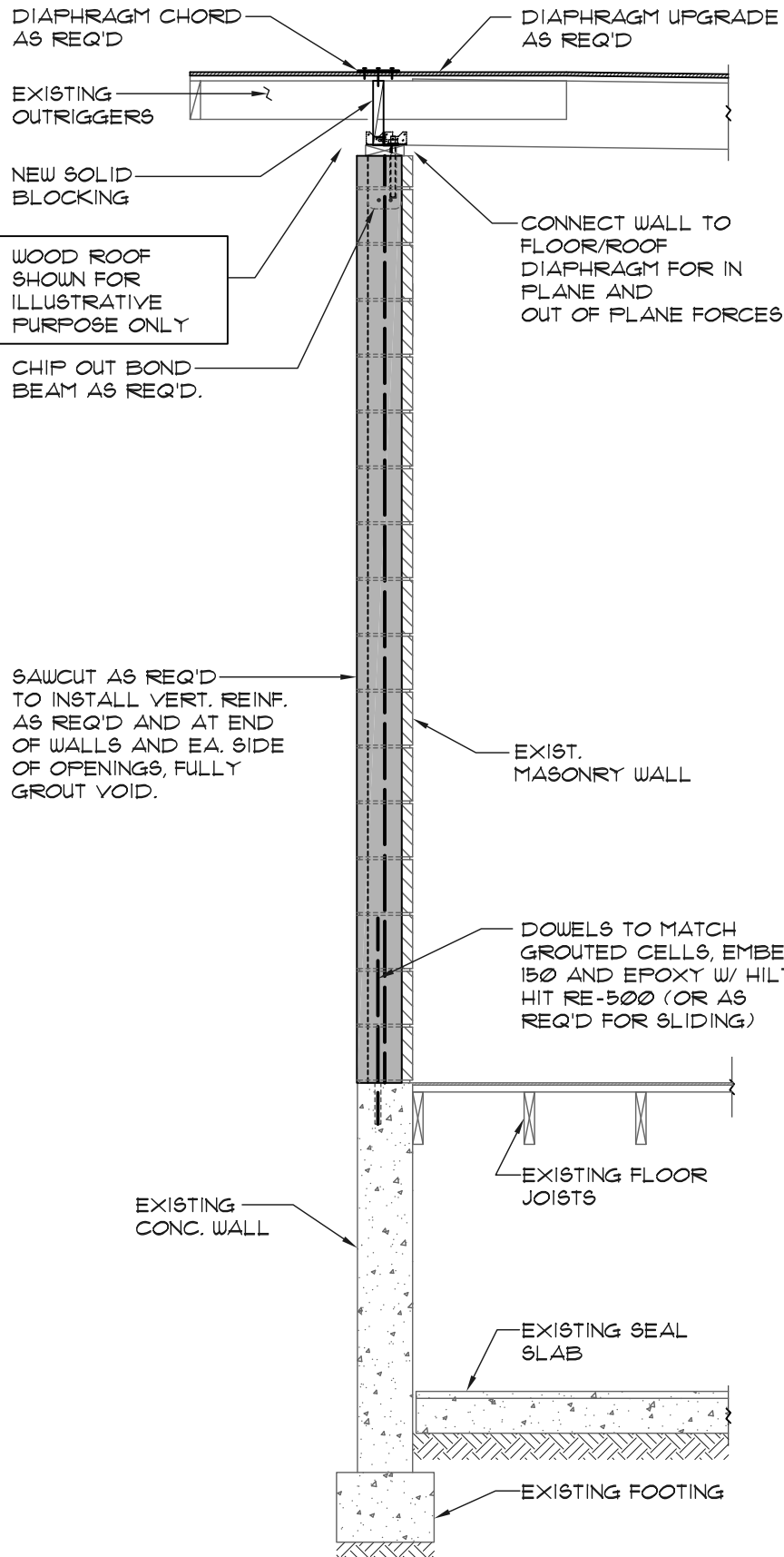

NAILS ALONG
PLYWOOD
PANEL EDGES
+ INTERIOR
FIELD

PLYWOOD AS REQ'D
STAGGER JOINTS

EXISTING
WOOD DECKING

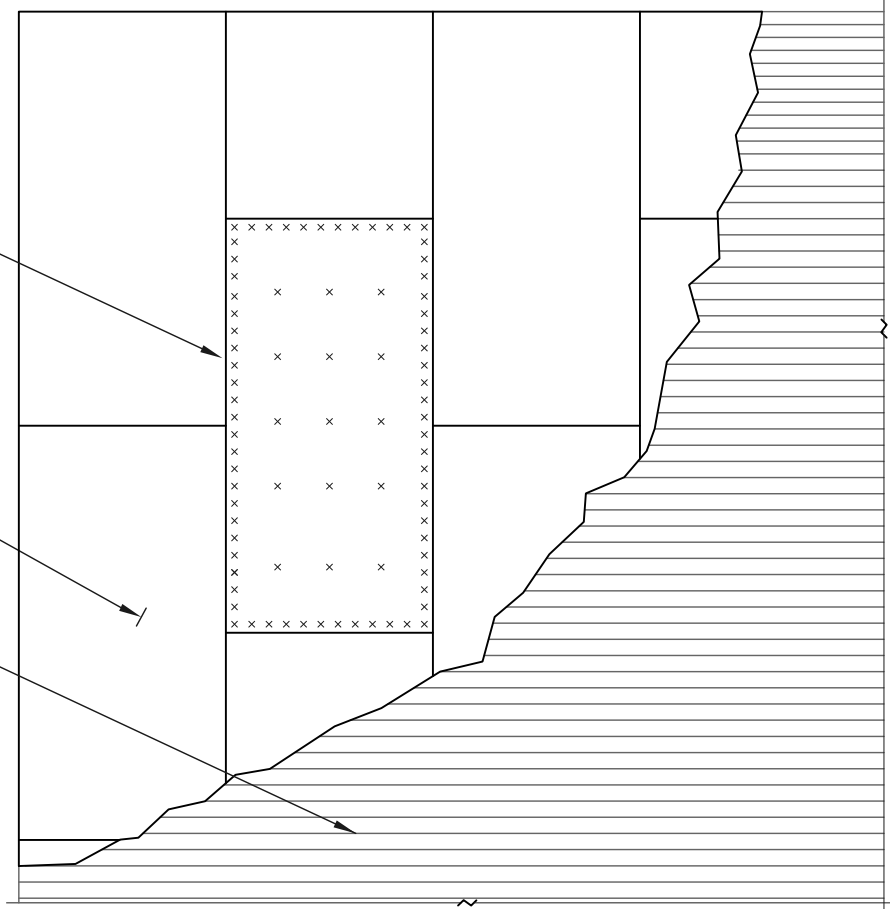

NOTES

1. ROOF SHEATHING TO BE NAILED WITH 64 NAILS (3.3mm?). DO NOT USE THIN GAUGE GUN NAILING STAPLES OR NAILS. NOTCHED HEAD NAILS ARE NOT ACCEPTABLE.
2. DO NOT NAIL THROUGH EXISTING JOINTS IN TONGUE AND GROOVE DECKING.
3. STAGGER JOINTS AND ORIENT PLYWOOD PANELS PERPENDICULAR TO DIRECTION OF TONGUE AND GROOVE DECKING.
4. NAIL TO CHORDS, DRAG STRUTS AND SHEAR WALLS

75 NAILS @100 O.C.
ALONG PLYWOOD
PANEL EDGE
AND @300 O.C. AT
INTERMEDIATE
SUPPORTS

38 NAILS @100 O.C.
ALONG PLYWOOD
PANEL EDGES
RUNNING
PERPENDICULAR
TO SUPPORTS

LOCATE PLYWOOD
JOINTS OVER EXIST.
JOISTS / STRAPPING
TYPICAL

EXISTING SHIP LAP

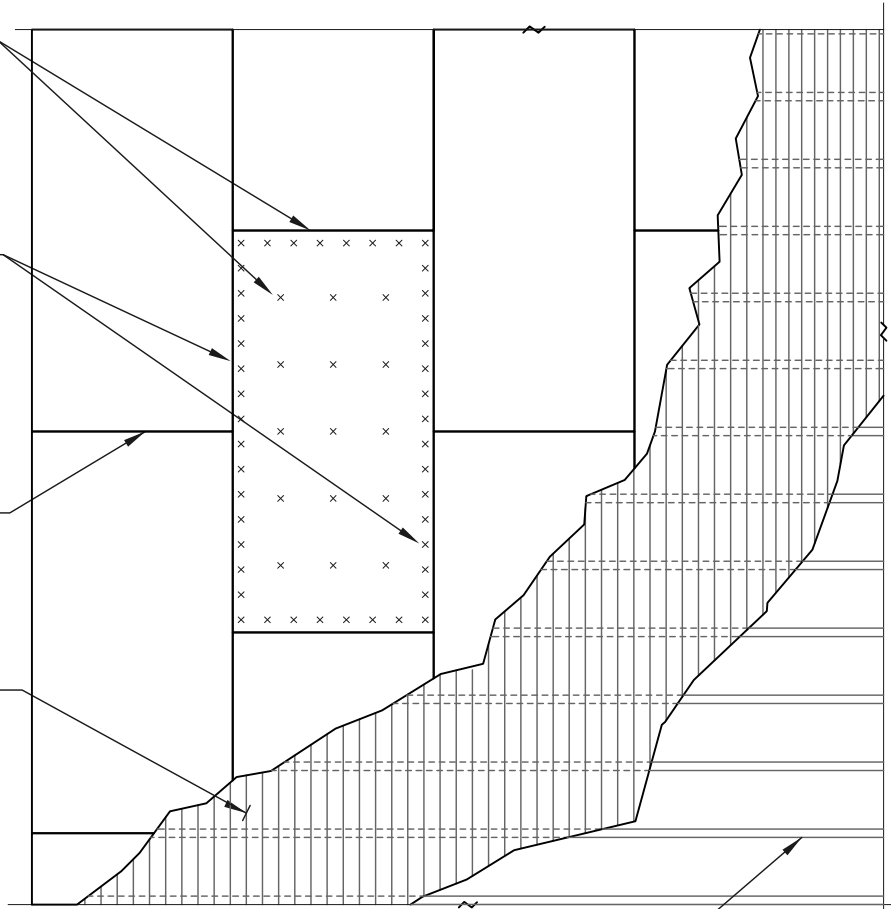

EXISTING ROOF
JOISTS

NOTE:

NAILING FOR ILLUSTRATION ONLY,
DESIGN TO SUIT SPECIFIC REQMT'S

SEE SHT 1/3 FOR ADDITIONAL
NOTES

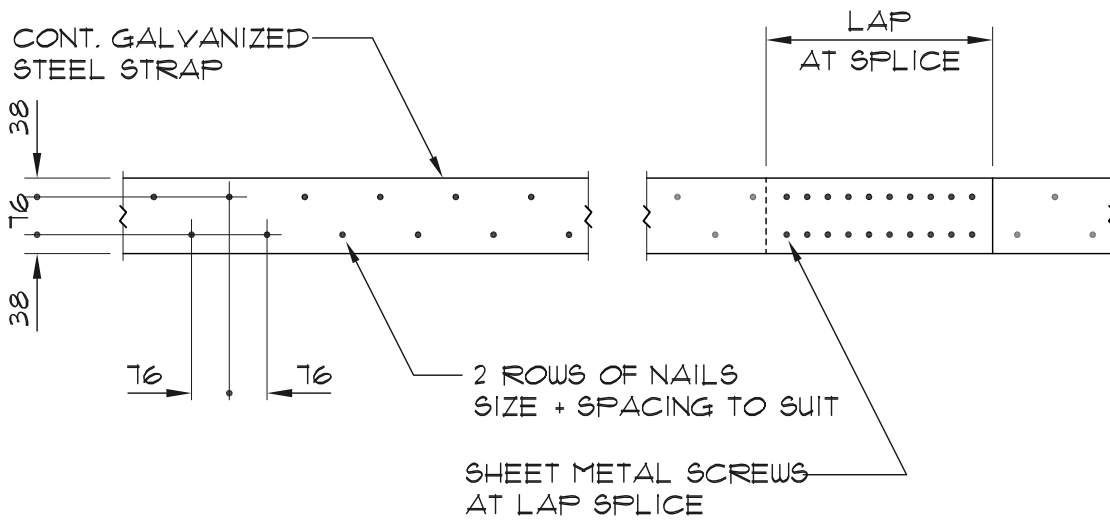

NOTES

1. CONTINUOUS GAUGE STEEL STRAP TO BE CENTRED OVER WALLS OR BLOCKS
2. FASTEN TO PLYWOOD SHEATHING WITH 2 ROWS OF NAILS AND SPLICE AS PER DETAILS.

SEISMIC RETROFIT GUIDELINES
 THIRD EDITION
 LIBRARY OF RETROFIT DETAILS
 SEPTEMBER, 2016

WOOD DIAPHRAGM #1
 SHEATH EXISTING ROOF WITH NEW PLY
 AND ADD SHEET METAL STRAPS

SCALE
 N.T.S
 SHEET No.
 WD
 #1(3/3)

DESIGNER TW
CHECKED BY _____

BUSH, BOHLMAN & PARTNERS LLP
CONSULTING ENGINEERS

PAGE NO. 01
DATE Nov 20, 2019
PROJECT NO. 7756

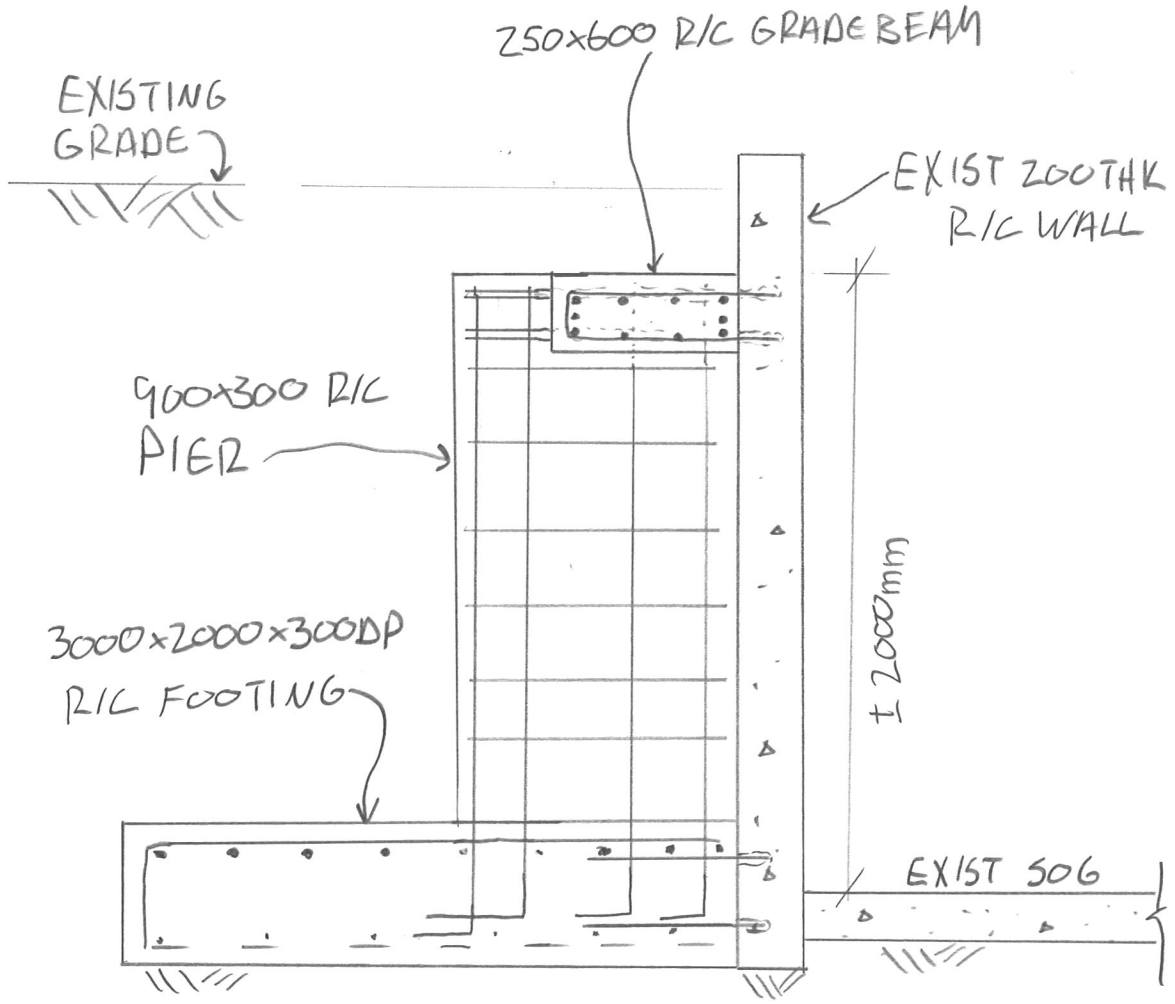

WHITE ROCK CITY HALL - SEISMIC STUDY
BASEMENT WALL UPGRADES NTS

SSK-1
REGULAR AGENDA
PAGE 106

Appendix B – Present Value of Renting Commercial Office Space

The growing annuity formula as follows:

$$PV = C \times \frac{1 - \left(\frac{1+g}{1+r}\right)^n}{r-g}$$

Where PV = Present Value, C = annual rent, g = % of annual rent increase, r = the discount value, and n = the term of the rental.

The term of the rental, n, is 50 years because the design useful life of a typical civic building is 50 years, without major renovation. The discount value, r, is provided as a range between 0.5% and 2.0%, based on the City’s investment rate of return and the City’s interest rate for loans. The annual rent increase is provided as a range between 2.5% and 4.0%. The Province of BC does not regulate commercial rental increases. These rates are determined at the time of the agreement.

The following figures show the present value of renting 32,067 sq.ft of commercial space relative to rent, growth rate of rent, and interest rate.

Figure 1: Present Value of Commercial Property at \$14/sq.ft

Rent	\$	14.00	per sq.ft		
Area		32067	sq.ft		
C	\$	448,938			
n		50	years		
r	g				
	2.5%	3.0%	3.5%	4.0%	
0.5%	\$	37,676,918	\$	43,391,059	\$
1.0%	\$	32,619,702	\$	37,387,221	\$
1.5%	\$	28,401,736	\$	32,394,644	\$
2.0%	\$	24,869,524	\$	28,226,677	\$
			\$	50,165,166	\$
			\$	43,023,567	\$
			\$	37,101,727	\$
			\$	36,820,346	\$

Figure 2: Present Value of Commercial Property at \$30/sq.ft

Rent	\$	30.00	per sq.ft		
Area		32067	sq.ft		
C	\$	962,010			
n		50	years		
r	g				
	2.5%	3.0%	3.5%	4.0%	
0.5%	\$	80,736,253	\$	92,980,840	\$
1.0%	\$	69,899,361	\$	80,115,474	\$
1.5%	\$	60,860,863	\$	69,417,094	\$
2.0%	\$	53,291,838	\$	60,485,736	\$
			\$	107,496,783	\$
			\$	92,193,357	\$
			\$	79,503,700	\$
			\$	78,900,742	\$

PRESENT: Mayor Walker
Councillor Chesney
Councillor Fathers, Chairperson
Councillor Johanson
Councillor Manning
Councillor Trevelyan (arrived at 4:03 p.m.)

ABSENT: Councillor Kristjanson

STAFF: D. Bottrill, Chief Administrative Officer
S. Lam, Deputy Corporate Officer
Jacquie Johnstone, Director of Human Resources
Candice Roffe, Health and Safety

Press: 0

Public: 0

1. **CALL MEETING TO ORDER**
The meeting was called to order at 4:00 p.m.

2. **ADOPTION OF AGENDA**

2019-G/L-124

It was MOVED and SECONDED

THAT the Governance and Legislation Committee adopt the Special meeting agenda for October 11, 2019 as circulated.

CARRIED

3. **WORKSAFE BC TRAINING – MIKE BENZ, WORKSAFE BC**
Mike Benz, Worksafe BC, provided a PowerPoint presentation titled “City Councillor’s Responsibilities in the Workplace”.

It was noted that employees have the following three (3) principal rights at work:

- To know what hazards are in the workplace
- The right to participate in Health and Safety activities in the workplace
- The right to refuse unsafe work without getting punished or fired.

Discussion ensued and the following information was provided in response to the Committee’s questions:

- Employees are trained to their relative responsibilities in their role (eg: restaurant patron would not be expected to enter the kitchen)
- A Councillor’s workplace could be that of an office environment, or a place where the public would be

- With respect to a recent incident where a Councillor entered a workplace when a tree was removed, Mr. Benz reported that he did not issue “orders of non-compliance” for the incident. Identified that further clarification with respect to what constitutes a workplace could prevent incidents like this in the future.
- When people enter a worksite, it is helpful to consider what that person should be wearing if they are representing the City in that scenario (eg: construction site could require a hard-hat or appropriate shoes).
- An employer is responsible to provide personal protective equipment in order for employees to carry out their job. Gear was not provided to Councillors as the employer identified that it was not required, as operational sites are not within jurisdiction for the elected official position. Council’s role is to address governance and policy – not operations.
- If Council wishes to move forward with worksite orientation, this can be provided by the City; however, Council members and the CAO should not be on a worksite.
- Supervisors should know their supervisors, understand what is happening at home, as that could impact how employees are on the worksite.
- Concerns with work safety, whether on private or public property, should call WorksafeBC and refrain from intervening
- It is an employee’s right to ask for more training

Mr. Benz provided the following outcomes that could have been taken with respect to the recent incident of a City representative entering the work site:

- A written order could have been issued to the City if he felt that proper instruction, training, or anything else needed, was not provided;
- If it was felt that the person in question entered a non-compliant workplace scenario, a written order could have been issued to the worker.

It was noted that written-orders are appended to a worker’s Social Insurance Number and ID, reiterating that they can stay with a worker’s record in perpetuity.

4. CONCLUSION OF THE OCTOBER 11, 2019 GOVERNANCE AND LEGISLATION COMMITTEE MEETING

The Chairperson declared the meeting concluded at 5:16 p.m.



Mayor Walker

Stephanie Lam
Deputy Corporate Officer

PRESENT: Councillor Fathers, Chairperson
Mayor Walker
Councillor Johanson
Councillor Kristjanson
Councillor Manning
Councillor Trevelyan (arrived at the meeting at 4:25 p.m.)

ABSENT: Councillor Chesney

GUEST: Don Lidstone, Lidstone & Company (City Solicitor)

STAFF: D. Bottrill, Chief Administrative Officer
T. Arthur, Director of Corporate Administration
D. Johnstone, Director of Human Resources (departed the meeting at 5:11 p.m.)
S. Lam, Deputy Corporate Officer

Press: 0

Public: 2

1. **CALL MEETING TO ORDER**
The meeting was called to order at 4:02 p.m.

2. **ADOPTION OF AGENDA**

2019-G/L-137

It was MOVED and SECONDED

THAT the Governance and Legislation Committee adopts the agenda for the October 29, 2019 meeting as circulated.

CARRIED

The City Solicitor was in attendance to provide an overview, through a PowerPoint presentation, of the City's Respectful Workplace Policy and the Council and Committee Procedure Bylaw.

3. **RESPECTFUL WORKPLACE POLICY**

The City's Respectful Workplace Human Resources Policy 405 pertains to:

- Respect among Council Members
- Respect in the Workplace (between staff)
- Respect between Council Members and staff

Common Policies in this regard can include:

- Code of Conduct for Council and staff
- Conflict of Interest over and above the *Community Charter*/Code of Ethics
- Nepotism
- Fit for Work (alcohol and drugs)
- Harassment and Bullying
- Discrimination

The reasons behind development of a policy in this regard include:

- Pre-empt and reduce conflict
- Set clear guideline and rules
- Ensure a professional work environment and high quality service delivery
- Protect the City's reputation / interests
- Limit legal liability (policy vs. operational decisions)
- Provides a roadmap for managing and resolving complaints or other difficult interactions
- Meet legal obligations
- Eliminates subjectivity
- Provides a basis for discipline

The City's Respectful Workplace Policy does have an extensive section regarding Disputes. Including between Council or between staff and Council.

Occupational Health and Safety, due to the number of staff working for the City, are required to have the program in place for all of the City's operations.

Common Policies in this regard can include:

- Expense claims
- Social Media and Technology Use
Action: It was noted that there is a new Twitter Account, where defamatory comments have been stated in regard to Council. This can now be traced, staff were asked to inquire on this.
- Attendance at work / sick time
- Discipline
- Scents in the workplace
- Accommodation (*Human Rights Code, Labour Code, Accessibly Act*)
- Dress code (not as common but something to look out for is to avoid clothing that promotes alcohol/drugs/message t-shirts)
- Privacy (possible fine of up to \$500,000 for breach of personal privacy, the City must be careful on documents they release to the public; and further the City must be careful on the information they collect - Is it actually required?)
- Inclusive Language (*Human Rights Code*, gender equality covered on all City publications)
- Workplace misconduct via social media
- Restricting employee's use of social media while at work
- Monitoring of employee's social media (acceptable and unacceptable use / on duty vs. off duty conduct)
- Setting parameters for City Social Media (whose responsibility and who monitors comments)

Councillor Trevelyan arrived at the meeting at 4:25 p.m.

A municipality cannot sue for defamation (ex. "Blackburg is a terrible place to live...") a municipality cannot take action in a circumstance such as this due to the *Charter of Rights of Freedoms*.

A member of Council or staff may sue for defamation.

It was noted that the City currently does not have noted parking for vans with wheelchair access. Mr. Lidstone stated the City has until 2024 to work on this; however, it should be the intent to address something like this when you can (*Accessibility Act* and the *Human Rights Code*).

When there is reliance on policies to impose discipline or to dismiss employees:

Employer must show:

- The policy has been distributed to employees
- It is known to the employee affected (training)
- It is reasonable and unambiguous
- It is consistently enforced by the employer
- Employees are warned that they will be disciplined or dismissed if they breach the policy
- The breach is sufficiently serious to justify dismissal

The Director of Human Resources departed the meeting at 5:11 p.m.

Code of Conduct

It is possible for Council to have a Code of Conduct in addition to the Oath of Office they take at their inaugural meeting. This is something that may be considered for the following reasons:

- Sets standards of expected behavior
- Supplements rules / standards of the *Community Charter*
- Once adopted it should align with all aspects of the City's culture including respectful workplace, harassment and communications

It was noted that there are limited sanctions if the City were to impose a Code of Conduct as they are not statutorily authorized including the following:

- Warning letter
- Pledge to recommit to Code of Conduct
- Requirement to take training
- Letter of reprimand
- Request an apology
- Public disclosure

There was an inquiry regarding Conflict of Interest. It was noted that this is addressed in the *Community Charter* under Sections 100 – 104.

If a Council Member attending a meeting considers that they are not entitled to participate in the discussion of a matter, or to vote on a question in respect of a matter, because the member has:

- (a) a direct or indirect pecuniary interest in the matter, or
- (b) another interest in the matter that constitutes a conflict of interest,

The Council member must declare this and state in general terms the reason(s) why they consider this to be the case (this will be noted in the minutes).

In regard to a direct or indirect pecuniary interest, if found, a Member of Council has participated in the discussion and/or voted on a matter that they are impacted this way they can be disqualified from office.

In regard to another interest in a matter that constitutes a conflict of interest, the vote the Councillor registered for the item would not count.

In British Columbia it is up to the Council Member to determine if there is a Conflict of Interest. The optics of the situation should be taken into consideration, if in question, it is best practice to declare the Conflict of Interest or get advice on the matter.

Meeting Recess / Reconvene

The Chairperson called a recess at 6:00 p.m. stating the meeting will be reconvened at 6:30 p.m. in the City Hall Council Chambers.

The Chairperson reconvened the meeting at 6:30 p.m. with all noted Members of Council and staff in attendance.

4. COUNCIL AND COMMITTEE PROCEDURE BYLAW, 2019, NO. 2232

The *Community Charter* requires the municipality adopt a Procedure Bylaw.

The procedure bylaw includes the following elements at minimum:

- Council meetings and Committee meetings
- How resolutions / bylaws are addressed
- Taking and certifying of minutes
- Giving notice
- Identify public posting places
- Acting Mayor
- Council also include other Rules of Order to reference in circumstances the bylaw is silent

There was an inquiry regarding committees / sub-committees / working groups.

There are two (2) types of Committees addressed in the *Community Charter* (CC):

Standing Committees (s.141.CC):

- 1) The Mayor must establish standing committees for matters the Mayor considers would be better dealt with by committee and must appoint persons to those committees.
- (2) At least half of the members of a standing committee must be council members.
- (3) Subject to subsection (2), persons who are not council members may be appointed to a standing committee.

Select Committees (s. 142 CC):

- (1) A council may establish and appoint a select committee to consider or inquire into any matter and to report its findings and opinion to the council.
- (2) At least one member of a select committee must be a council member.
- (3) Subject to subsection (2), persons who are not council members may be appointed to a select committee.

From this there can also be the following:

Sub-committees:

A committee may appoint members to a sub-committee to inquire into matters and to report and make recommendations to the committee for a specific purpose. Sub-committee may be formed in the circumstance there is a heavy workload and there are items that can be broken down and worked on with the sub-committee's advice and recommendations coming back to the originating committee. Meetings of the sub-committee are open to the public (subject to statutory closed meeting matters under s. 90 CC), must include agenda, meeting minutes and be posted just as a committee meeting held by the City of White Rock.

Working groups:

A committee or sub-committee may form a working group for the limited purpose of

- (1) gathering, summarizing or preparing a presentation of information, including research and analysis, to deliver to the committee or sub-committee, or
- (2) carrying out a specific prescribed activity (ex. parade float production, taking available information and placing it into a specified format for a committee).

Due to the limited nature of the working group, they would perform their work on their own. If a working group provides advice and recommendations or an opinion on matters of policy to Council, a committee or a sub-committee, then it may be characterized as a sub-committee and not a mere working group - this type of work is to be done in the committee or sub-committee meeting format so the public have to opportunity to see and hear how recommendations to Council are formed. A working group does not meet in a formal circumstance (no agenda, meeting minutes, meeting notice is required).

Public Meetings:

If an item is referred to a committee by Council, the intent of Council would be to have the committee discuss it in a public meeting (subject to statutory closed meeting matters under s. 90 CC) . Staff are required to place the item referred by Council on the Committee agenda. Once the topic is on the agenda the committee can determine how they will address it, either at the current meeting or a future meeting or form a sub-committee to begin to address the topic.

There are many terminologies that can be used to describe a committee including but not limited to:

- Standing committee as described in the CC
- Select committee as described in the CC
- Sub-committee, formed by an original committee, by members of the appointed committee to inquire into, report and make recommendations to the committee for a specific purpose
- Task Force, to work on a specific topic (usually by a set timeline), same guidelines as a Select committee
- Advisory committee
- Panel, the City has a Parcel Tax Review Panel as described in the CC (and an Advisory Design Panel)
- Board, the City has a Board of Variance in accordance with the *Local Government Act*
- Commission

All City committees and entities in the list above require public notice and minutes, and are to be open to the public (subject to statutory closed meeting matters under s. 90 CC).

Further Discussion ensued and the following points were noted:

- Speaking times permitted at a Council meeting. It was noted that some of Council were not in favour of the current procedure bylaw where the speaking time on an items is limited as twice for five (5) minutes each time.
- Concern was noted at the length of time the meetings were taking, limiting speaking times in accordance with the procedure bylaw may be a way to alleviate this.
The bylaw also includes wording where there is an option that the speaking time can be extended by the majority of Council.
- Staff are to review the Council and Committee Procedure Bylaw and bring it forward with suggested amendments so Council can continue discussion as to possible amendments at a future Governance and Legislation Committee meeting.

5. **CONCLUSION OF THE OCTOBER 29, 2019 GOVERNANCE AND
LEGISLATION COMMITTEE MEETING**

The Chairperson declared the meeting concluded at 7:03 p.m.

Councillor Fathers, Chairperson

Tracey Arthur, Director of
Corporate Administration

PRESENT: Councillor Fathers
Mayor Walker
Councillor Chesney
Councillor Johanson
Councillor Kristjanson (arrived at 5:04 p.m.)
Councillor Manning
Councillor Trevelyan

STAFF: D. Bottrill, Chief Administrative Officer
T. Arthur, Director of Corporate Administration
J. Gordon, Director of Engineering and Municipal Operations
S. Lam, Deputy Corporate Officer

Press: 0
Public: 1

1. CALL MEETING TO ORDER
The meeting was called to order at 5:00 p.m.

2. ADOPTION OF AGENDA

2019-G/L-144 **It was MOVED and SECONDED**
THAT the Governance and Legislation Committee adopts the agenda for the
November 18, 2019 Committee meeting.

CARRIED

3. ADOPTION OF MINUTES
a) November 4, 2019

2019-G/L-145 **It was MOVED and SECONDED**
THAT the Governance and Legislation Committee adopts the following meeting minutes
as circulated:
a) November 4, 2019.

CARRIED

Due to time constraints, Items 4 and 5 were deferred from the November 4, 2019
Governance and Legislation Committee.

Councillor Kristjanson arrived at the meeting at 5:04 p.m.

4. MEETING FREQUENCY / STRUCTURE
Councillor Fathers requested this item be placed on the agenda for discussion purposes.

The following discussion points were noted:

- Find the Council meeting days long, too many meeting packed into one day, this can be counterproductive
- Drained after the long day but also not interested in meeting every week

- One meeting is preferred before the regular Council, and time needs to be managed during the meetings
- Would rather do one (1) or two (2) extra hours than give up an entire further evening
- This is one (1) year with the new Council, perhaps wait and see how the second goes
- Would like to keep in mind 4 – 5 hours of meetings is a good limit
- The 5:00 p.m. start time appears to work well
- Could consider other nights for some of the standing committee meetings when needed to address outstanding business

2019-G/L-146

It was MOVED and SECONDED

THAT the Governance and Legislation Committee directs that meetings are to be scheduled to begin not before 5:00 p.m. on the regular Council Mondays.

CARRIED

2019-G/L-147

It was MOVED and SECONDED

THAT the Governance and Legislation Committee directs that the procedure bylaw be amended to state that Council meetings will not continue past 9:30 p.m., with the provision that the meeting can be extended through a majority vote of Council.

CARRIED

Councillors Kristjanson and Trevelyan voted in the negative

Note: The City's Council and Committee Procedure Bylaw will be brought forward with this noted amendment

Further discussion ensued and it was noted that Council may want to review the number of delegations and presentations permitted at a Council meeting. This item may be discussed further when the City's Council and Committee Procedure Bylaw is brought forward for an update.

5.

POLICY REVIEW – ENGINEERING AND MUNICIPAL OPERATIONS (600 SERIES)

As part of the ongoing City Policy review, the following policies were reviewed by the Engineering and Municipal Operations department. These policies were presented for discussion / consideration.

Note: *An index summarizing what has been amended is included for reference purposes.*

- 1) Engineering and Municipal Operations is proposing that matters addressed in Policies No. 614-616 be consolidated into Policy No. 603. Recommendation #1 addresses these proposed changes.
- 2) Policies that have no proposed amendments are listed below to be ratified under Recommendation #3.
- 3) Policies that have proposed amendments are noted with tracked changes and are presented for the Committee's endorsement under Recommendation #4.

2019-G/L-148

It was MOVED and SECONDED

THAT the Governance and Legislation Committee recommends that Council:

- 1) Repeals the following Engineering and Municipal Operations Policies:
 - a) Policy 614 – Roads Inspection Maintenance;
 - b) Policy 615 – Sidewalks Inspection and Maintenance;
 - c) Policy 616 – Curbs Inspection and Maintenance; and
- 2) Endorses Engineering and Municipal Operation Policy No. 603 - *Inspections and Maintenance of Sidewalks and Roadways*, which has been revised to include matters addressed in Policies No. 614-616.; and
- 3) Endorses the following policies as circulated in the agenda with no requested amendments:
 - Policy 604 – Ditch Elimination;
 - Policy 606 – Banner over City Streets;
 - Policy 613 – Sweeping and Cleaning;
 - Policy 617 – Parking Lot Inspection and Maintenance;
 - Policy 618 – Centre Lines, Lane Lines, Crosswalks, and Stop Bars – Inspection and Maintenance;
 - Policy 619 – Street Lights;
 - Policy 620 – Traffic Control Signage and Signals;
 - Policy 621 – Equipment – Maintenance;
 - Policy 622 – Polychlorinated Biphenyls (PCB's);
 - Policy 623 – Insects and Pest Infestation – Private Lands;
 - Policy 624 – Asbestos;
 - Policy 625 – Chemical and Hazardous Materials;
 - Policy 626 – Bridges – Inspection and Maintenance;
 - Policy 629 – Retaining Wall;
 - Policy 630 – Facilities Inspection and Maintenance;
 - Policy 631 – Facilities Lighting; and
 - Policy 634 – White Rock Pier; and
- 4) Endorses the following policies with suggested amendments noted as tracked changes as circulated in the agenda:
 - Policy 600 – Roads/Road Allowance;
 - Policy 627 – Public Open Spaces Inspection and Maintenance;
 - Policy 628 – Snow and Ice Control;
 - Policy 632 – Sanitary Sewers;
 - Policy 633 – Storm Drainage System;
 - Policy 635 – Beach Access – Inspection and Maintenance;
 - Policy 636 – Sports Fields; and
 - Policy 637 – Sport Courts.

CARRIED

Councillor Kristjanson voted in the negative

There was concern noted in regard to curb letdowns and ensuring they are not hazardous but also meet City of White Rock standards. Specifically a recent curb let down constructed at Johnston Road and Russell Avenue. It was noted the City could change this to their standard at a cost to the taxpayer. Previously staff have been

REGULAR AGENDA

PAGE 119

working with the contractor requesting it be amended to the City's standard rather than only to the building code.

Subsequent Motion

2019-G/L-149

It was MOVED and SECONDED

THAT the Governance and Legislation Committee directs staff to bring forward a corporate report that will discuss creation of a new policy regarding new construction, when issues are identified with the work that they be addressed in an reasonable timeline so they are brought up to the City of White Rock standards.

CARRIED

Councillor Johanson voted in the negative

Subsequent Motion

2019-G/L-150

It was MOVED and SECONDED

THAT the Governance and Legislation Committee directs staff to change the curb let down at Johnston Road and Russell Avenue to bring it up to the City of White Rock standard as soon as possible.

CARRIED

There was some further discussion regarding Policy 635 – Beach Access, it was noted that this item has been placed in the upcoming Financial Plan process for discussion. The Director of Engineering and Municipal Operations has requested budget funds (approximately \$110,000) to enhance the beach access by the boat launch with the result it is to be fully accessible.

6.

CONCLUSION OF THE NOVEMBER 18, 2019 GOVERNANCE AND LEGISLATION COMMITTEE MEETING

The Chairperson declared the meeting concluded at 5:53 p.m.

Councillor Helen Fathers, Chairperson

Tracey Arthur, Director of
Corporate Administration

- PRESENT:** Councillor Fathers, Chairperson (arrived at the meeting at 4:25 p.m.)
Mayor Walker
Councillor Johanson
Councillor Kristjanson (arrived at the meeting at 4:34 p.m. and departed the meeting at 5:45 p.m.)
Councillor Manning
Councillor Trevelyan
- ABSENT:** Councillor Chesney
- GUEST:** Don Lidstone, Lidstone & Company (City Solicitor)
- STAFF:** D. Bottrill, Chief Administrative Officer
C. Isaak, Director of Planning and Development Services
T. Arthur, Director of Corporate Administration
- Press: 0
Public: 1

1. **CALL MEETING TO ORDER**
The meeting was called to order at 4:10 p.m.

2. **ADOPTION OF AGENDA**

2019-G/L-151

It was MOVED and SECONDED

THAT the Governance and Legislation Committee adopts the agenda for the November 27, 2019 meeting as circulated.

CARRIED

The City Solicitor was in attendance to provide an overview, through a PowerPoint presentation, of the City's Respectful Workplace Policy and the Council and Committee Procedure Bylaw.

3. **CITY PLANNING PROCEDURES AND PROCESSES**

Don Lidstone, City Solicitor, provided an orientation through PowerPoint regarding planning related matters.

OFFICIAL COMMUNITY PLAN (OCP)

- Purpose – Statement of objectives/policies on future land use, density intensity, servicing, open space /parks and Development Permit designation (area, guidelines and objectives)
- They may also include:
 - Neighbourhood plans
 - They ensure the community develops with unified objectives
 - Required versus optional policy content
- Council must identify the groups to consult with, it was noted that the City could have a policy on.

ZONING BYLAW

- Powers of the zoning bylaw: divide area into zones, and regulate or prohibit use, density, setback and side yard, height, lot coverage, accessory uses.
- The zoning bylaw can permit density bonus or the shift of density / amenities / community amenity contributions
- The zoning bylaw does not apply to First Nation land

Councillor Kristjanson arrived at the meeting at 4:34 p.m.

ZONING BYLAW AND OCP INTERFACE

- There is a legal effect of OCP and effect on the Zoning
- There is not a need to rezone land to comply the City's OCP
- Council may not adopt a bylaw that is inconsistent with the OCP (the OCP in place at the time)
- You can't undertake work that is inconsistent with the OCP (the OCP in place at the time)
- OCP exists as a parent the City does not have to bring all bylaws up to date with the approval of a new OCP
- Pre-zoning: for whole municipality can be done but rare
Fairness for developers was questioned if the City were to amend a pre-zoned area proposal can be refused.
- Where can the City place the formula that a percentage of units must be below market (not in zoning bylaw or covenant)? Noted that this must be in a Housing Agreement Bylaw

DEVELOPMENT PERMITS (DP) / DEVELOPMENT VARIANCE PERMITS (DVP)

- All major developments have DP areas designated in the OCP for one or more purposes (ex: protection of natural environment)
- They can vary or supplement zoning or subdivision rules (not use or density)
- Control the form and character of building
- Can be intensive residential DPs for detached homes
- A member of the public has four (4) ways to seek approval:
 - Board of Variance (BOV) – variances other than use or density (undue hardship)
 - Council by making an application for DVP
 - New DP and ask for a variance
 - Council approval for an amendment to the zoning bylaw
- A building permit must be consistent with the zoning, if all is consistent with the zoning and building code etc, then staff must issue the permit
- If a DP application is consistent with OCP guidelines / provisions then the permit must be issued

PLANNING PROCEDURES BYLAW (CITY'S IS FOUR (4) YEARS OLD)

- It is required for the municipality to have a Planning Procedures Bylaw (establishes details of application processes for rezoning, subdivision, DP and DVP etc.)
- The City's Planning Procedures bylaw is solid

PLANNING PROCEDURES

- What is the extent a member of Council should be involved in the application? If a member of Council wants to get involved, it is alright during the early stages of the development to say how a member of Council feels about the development but cannot speak on behalf of Council unless authorized to do so by Council.

Once notice for a public hearing is issued this is the start of the process. If the application involves a rezoning or OCP there must be a public hearing and Council sit as of "judges" and Council must have an open mind / amendable to persuasion by all submissions.

Public Hearing Information was not discussed further as it was covered in the October 29, 2019 Orientation Session with Council.

PROCEDURAL FAIRNESS HEARINGS:

- Example of the when the need to ensure there is procedural fairness: revoking a license or permit then a procedural fairness hearing must be held (reasonable opportunity to make a submission before a decision is made)
- Moratorium on Development, this cannot be done by simple resolution by Council (no effect), must be done by zoning bylaw
- There is an obligation of Council to consider every application

Meeting Recess / Reconvene

The Chairperson called a recess at 5:54 p.m. stating the meeting will be reconvened at 6:35 p.m. in the City Hall Council Chambers.

The Chairperson reconvened the meeting at 6:30 p.m. with all noted Members of Council, excluding Councillor Kristjanson and staff in attendance.

- What is the Council risk on Bylaws and Permits - when Council downzoning or reducing property value? There is no legal liability as a general rule. What Council is doing when rezoning, you are legislating and cannot be liable for that. With the exception if Council is doing so for a public purpose (designated for a tunnel etc.)

APPROVING OFFICER

- Appointed by Council
- Independent autonomous entity under statute
- Council adopts the zoning and subdivision bylaws, then the Approving Officer has independent power to approve subdivisions or not

- Role of the Approving Officer: approves subdivision, bound only by zoning and subdivision bylaws but not by OCP or Council directions or policies
- Must take into account public interest
- Some Approving Officers use preliminary approval process (list of items that must be met)
- Bare land strata plan, phased strata plans
- If someone is opposed to decision of the Approving Officer they can go to court and tries to attack the decision, generally speaking their decision is upheld.

TEMPORARY USE PERMITS (TUP)

- Allows temporary uses not allowed in the zoning bylaw
- TUP areas will be designated in the OCP
- Impose all kinds of conditions
- Normally 2 – 3 years and renewed once
- Must go through a public hearing process

PHASED DEVELOPMENT AGREEMENTS (PDA)

- The City uses PDA, they have a good template and process
- Agreements between the City and a property owner that includes whatever the parties agree to, anything to do with infrastructure and you may include any amenities
- Permits you to impose and keep an amenity contribution
- Also conditions of use like a Letter of Credit, how it works, and term (term is important normally 10 years may be extended to 20 years if the Inspector of Municipalities signs off on it).
- Public Hearing for a PDA would be the same as a zoning hearing, quite often considered at the same time.

OTHER LAND USE POWERS:

- Runoff control (run off from the roof from other parts of the lot), very important when you alter the historical drainage flow (a bylaw to this item is a good idea)
- The City does not have this, subdivision and servicing bylaw does deal with drainage. Some aspects are covered but not directly to the City, this may be something that the City may look forward.

2019-G/L-152

It was MOVED and SECONDED

THAT the Governance and Legislation Committee directs staff to bring forward information in regard a run off control bylaw.

CARRIED

- Off-street parking and loading spaces
- Signs are a possible litigation concern – Council does not have the authority in regard to the content of the sign - Freedom of Expression - only the safety and location.

- Landscaping, must have a bylaw to require it, this is critical to have and it must include enforcement provisions
- Trees, can have tree cutting bylaw
- Set up special council meetings so the first three readings can be considered, and a further meeting is required for adoption/final reading
- Green roofs, authority for any new development there are technical considerations to ensure no leakage / flooding and landscaping is kept intact
- Living walls are covered under the *Building Act*, not the same as the green roof requirement
- Building Energy / GHG emissions, in order to comply the City can wave part of the building fee

REGIONAL GROWTH STRATEGY AND REGIONAL CONTEXT STATEMENTS

- Each member municipality must adopted a Regional Context Statement (RCS)– describes how local land use policies in the OCP relate to the Regional Growth Strategy (RGS)
- All bylaws must be consistent with the RGS (Council must not adopt a bylaw or undertake a work inconsistent with the RCS)
- Council are not bound by RGS
- RGS, it will align with TransLink’s Strategic Plan.

4. CONCLUSION OF THE NOVEMBER 27, 2019 GOVERNANCE AND LEGISLATION COMMITTEE MEETING

The Chairperson declared the meeting concluded at 7:35 p.m.

Councillor Fathers, Chairperson



Tracey Arthur, Director of
Corporate Administration

PRESENT: Councillor Fathers, Chairperson
Mayor Walker
Councillor Chesney
Councillor Johanson
Councillor Kristjanson
Councillor Manning
Councillor Trevelyan

STAFF: D. Bottrill, Chief Administrative Officer
T. Arthur, Director of Corporate Administration
C. Isaak, Director of Planning and Development Services
E. Stepura, Director of Recreation and Culture
D. Kell, Manager of Communications and Government Relations
S. Lam, Deputy Corporate Officer

Press: 0
Public: 1

1. **CALL MEETING TO ORDER**
The meeting was called to order at 5:00 p.m.

2. **ADOPTION OF AGENDA**

2019-G/L-154

It was MOVED and SECONDED

THAT the Governance and Legislation Committee adopts the agenda for December 16, 2019 as circulated.

CARRIED

3. **ADOPTION OF MINUTES**

- a) October 11, 2019 – Worksafe BC
- b) October 29, 2019 – Committee Procedures
- c) November 18, 2019
- d) November 27, 2019 – Planning Procedures

2019-G/L-155

It was MOVED and SECONDED

THAT the Governance and Legislation Committee adopts the following meeting minutes as circulated:

- a) October 11, 2019 – Worksafe BC;
- b) October 29, 2019 – Committee Procedures;
- c) November 18, 2019; and
- d) November 27, 2019 – Planning Procedures.

CARRIED

4. **COMMUNITY AMENITY CONTRIBUTION FORUM FORMAT**

The Committee discussed the format for the Community Amenity Contribution (CAC) Forum anticipated for the New Year (January 20, 2020 / to be conducted “In House”, 5:30 p.m. to 7:30 p.m.)

The Committee noted the following:

- It will be important to start with context information for those in attendance to understand what CAC’s are, where they come from and what they can be used for
- Encourage participation, concentrate on further ways to engage the public
- Would like to see some eye catching ads for it, try to reach more people (ex: How would you spend \$6M)
- Would like to see amounts or estimates included with the various projects noted
- There be “storyboards” to note the possible projects to consider use of CAC funds, so the public have opportunity to understand the context
- Would like to see and ideas as they come into the Forum, staff can collate them and they can be discussed
- Would like to see a mechanism to vote on the various items.
- Encourage people to fill in survey forms either as they come in or upon leaving
- Potential for matching grants to be noted on the “storyboard” information
- Contact points be made at the City facilities including the library, surveys to be provided so those who want to participant this way can again a way to reach more persons
- Would like this to be more of a charrette style format
- Tables with a facilitator at each table

2019-G/L-156

It was MOVED and SECONDED

THAT the Committee directs that the public forum in regard to Community Amenity Charges (CAC’s) scheduled for 2020 be scheduled with the following aspects:

- round tables with facilitators (charrette style)
- Presentation at the start with context information for those in attendance to understand what CAC’s are, where they come from and what they can be used for.

CARRIED

5. **PROPOSED MARINE DRIVE TASK FORCE VISIT TO WHITE ROCK SISTER CITY: LA CONNER**

Discussion stemming from Marine Drive Task Force regarding a possible visit to La Conner.

Discussion comments included:

- Would like to see this as a Council to Council meeting, not the Committee members going to speak on behalf of White Rock
- One of the main purposes of going is to view firsthand how the City of La Conner created their ambiance, look for ways to bring ideas back that can be utilized in White Rock
- Opportunity to reaffirm the Sister City relationship, Council to Council as the new City Council have not yet met with La Conner

2019-G/L-157

It was MOVED and SECONDED

THAT the Committee directs that the topic of a Council visit to meet with the Council of the Sister City of La Conner be forwarded to the Marine Drive Task Force and the Economic Investment Committee so they can outline any questions / comments that can be addressed by Council at a future Council to Council meeting.

CARRIED

It was noted that staff would work toward a date in the New Year for a possible Council to Council meeting with the Council of their sister City, La Conner, Washington USA including details of travel etc.

6.

SOCIAL MEDIA POLICY UPDATE FOR THE CITY OF WHITE ROCK

Corporate report dated December 16, 2019 from the Director of Corporate Administration titled “Social Media Policy Update for the City of White Rock”.

The Manager of Communications and Government Relations outlined the information within the corporate report and referenced the following “On-Table” examples:

- Social Media posts; and
- Google Analytics for the City’s Website.

Discussion comments included:

- Tips or Guidelines to be placed in the Social Media Policy or a separate policy so there is clear and uniform guidance (ex. when Council are responding as private citizen that it is clear)
- Pier Cam is one of the most viewed aspects of the City’s website
- It was noted that people are responding well to the OCP information
- It was noted on the page of the Pier Cam on the website that only ½ the page is being utilized, staff will look into this
- Amount of time spent of Social Media is approximately 1.5 hours per day, there could be more but there is a question of how much staff time there is for this along with other tasks
- The same comment applies to how much time there is spent on the website
- Communications ensures City standards are kept and when more time is spent they can ensure the information remains fresh and current. The City departments do not have the labour to give the website the same attention
- It was clarified that there are two (2) full time staff and one (1) Temporary Full Time staff person
- If the department were to have only two (2) full time staff, the current standards and some of the new initiatives will not be all attainable (with one less person)
- Will have to weigh this consideration with the entire City budget

2019-G/L-158

It was MOVED and SECONDED

THAT the Governance and Legislation Committee

1. Receives for information the corporate report dated December 16, 2019, from the Director of Corporate Administration titled “Social Media Policy Update for the City of White Rock”; and
2. Endorses the social media policy as attached in Appendix A and direct staff to develop Social Media Guidelines for internal use that allow collaborative engagement.

CARRIED

7.

BUSINESS LICENSING APPROACH FOR PASSENGER DIRECTED VEHICLE SERVICES

Corporate report dated December 16, 2019 from the Director of Planning and Development Services titled “Business Licensing Approach for Passenger Directed Vehicle Services”.

The Director of Planning and Development Services outlined the information within the corporate report.

Discussion comments included:

- Any contractor coming in to work in the City is required to obtain a business licence
- Universal Business License – all municipalities, a regional approach

Meeting Recess

The Chairperson recessed the meeting for a break until after the conclusion of the Regular Council meeting later in the evening.

Meeting Reconvened

The Chairperson reconvened the meeting at 9:14 p.m. and noted that the remaining items from the agenda will come forward to the next Governance and Legislation Committee meeting.

The following items will be addressed at the next Governance and Legislation Committee meeting:

- **BUSINESS LICENSING APPROACH FOR PASSENGER DIRECTED VEHICLE SERVICES**

(Discussion occurred on the topic however the Committee did not consider the recommendation as outlined in the corporate report)

- **FIRST NATION ACKNOWLEDGEMENT AT COUNCIL MEETINGS**
- **LEAN GOVERNMENT STUDY – COUNCILLOR MANNING**
- **COUNCIL AND COMMITTEE PROCEDURE BYLAW**
- **COUNCIL POLICY NO. 111: ORDER OF PROCEEDINGS**
- **POLICY REVIEW**
- **PLANNING AND DEVELOPMENT SERVICES (500 SERIES)**
- **RECREATION AND CULTURE POLICY NO. 708 – PUBLIC ART**

- **HUMAN RESOURCES POLICY NO. 401 – EMPLOYEE RECOGNITION PROGRAM**
- **COUNCIL MEMBER VOTING RECORDS**
- **UBCM CHILD CARE PLANNING PROGRAM GRANT**

14. **CONCLUSION OF THE DECEMBER 16, 2019 GOVERNANCE AND LEGISLATION COMMITTEE MEETING**

The Chairperson declared the meeting concluded at 9:14 p.m.

Councillor Fathers, Chairperson



Tracey Arthur, Director of
Corporate Administration

Unapproved

PRESENT: Mayor Walker
Councillor Chesney
Councillor Fathers
Councillor Johanson
Councillor Kristjanson
Councillor Manning
Councillor Trevelyan

STAFF: D. Bottrill, Chief Administrative Officer
T. Arthur, Director of Corporate Administration
C. Isaak, Director of Planning and Development Services
S. Lam, Deputy Corporate Officer

Press: 0
Public: 8

1. **CALL MEETING TO ORDER**
The meeting was called to order at 6:30 p.m.

2. **ADOPTION OF AGENDA**

2019-LU/P-043 **It was MOVED and SECONDED**
THAT the Land Use and Planning Committee adopts the agenda for December 16, 2019 as circulated.

CARRIED

3. **ADOPTION OF MINUTES**
a) December 2, 2019

2019-LU/P-044 **It was MOVED and SECONDED**
THAT the Land Use and Planning Committee adopts the following meeting minutes as circulated:

a) December 2, 2019.

CARRIED

4. **REVISED BUILDING DESIGN AND DRIVEWAY ACCESS LOCATION FOR THE DEVELOPMENT APPLICATION AT 1453 STAYTE ROAD (ZON&MJP 18-017)**
Corporate report dated December 16, 2019 from the Director of Planning and Development Services titled "Revised Building Design and Driveway Access Location for the Development Application at 1453 Stayte Road (ZON&MJP 18-017)".

The Director of Planning and Development Services gave an outline of the corporate report. This is an amendment to the application that was before the Committee in March 2019. The amendments were outlined in detail.

The following discussion points were noted:

- Questions were asked in regard to the nearby building to the south, the Arcadian and it's zoning / density
- Clarification was given that permitting a project to go to public hearing does not reflect on how Council will vote
- Some concern that the footprint is still large compared to the nearby properties / separation between the homes, would like to hear from the public

The Architect for the projects was asked to come forward for some questions:

- Is there a plan for the existing trees on the site? They will be removed in accordance with the Arbourist report that was conducted
- Due to moving the driveway there will now be 49 units as opposed to 50

2019-LU/P-045

It was MOVED and SECONDED

THAT the Land Use and Planning Committee:

1. Receives for information the corporate report dated December 16, 2019 from the Director of Planning and Development Services titled "Information Report on Revised Development Application – 1453 Stayte Road (ZON&MJP 18-017)"; and
2. Directs staff to prepare a revised draft Zoning Amendment Bylaw and Development Permit for Land Use and Planning Committee consideration after the applicant provides the final drawings and Traffic Impact Study regarding the proposed driveway access location change.

CARRIED

Councillor Johanson voted in the negative

5.

CONCLUSION OF THE DECEMBER 16, 2019 LAND USE AND PLANNING COMMITTEE MEETING

The Chairperson declared the meeting concluded at 6:47 p.m.

Mayor Walker



Tracey Arthur, Director of
Corporate Administration

PRESENT: Mayor Walker
Councillor Chesney
Councillor Fathers
Councillor Johanson
Councillor Kristjanson
Councillor Manning
Councillor Trevelyan

STAFF: Dan Bottrill, Chief Administrative Officer
T. Arthur, Director of Corporate Administration
S. Kurylo, Director of Financial Services
J. Gordon, Director of Engineering and Municipal Operations
C. Isaak, Director of Planning and Development Services
P. Lemire, Fire Chief
J. Johnstone, Director of Human Resources
C. Zota, Manager of Information Technology
S. Johnson, Manager of Budget

Press: 1
Public: 2

1. AGENDA APPROVAL

2019-F/A-038

It was MOVED and SECONDED

THAT the Finance and Audit Committee adopts the agenda for the meeting scheduled for December 9, 2019 as circulated.

CARRIED

2.

PREVIOUS MINUTES

a) Finance and Audit Committee Meeting – September 30, 2019

2019-F/A-039

It was MOVED and SECONDED

THAT the Finance and Audit Committee adopts the minutes of their meeting held September 30, 2019 as circulated.

CARRIED

3. CORPORATE REPORTS

3.1 RAINBOW CROSSWALKS AT FIVE CORNERS

Corporate report dated December 9, 2019 from the Director of Engineering and Municipal Operations titled “Rainbow Crosswalks at Five Corners”.

2019-F/A-040

It was MOVED and SECONDED

THAT the Finance and Audit Committee receives for information the corporate report dated December 9, 2019 from the Director of Engineering & Regional Utilities titled “Rainbow Crosswalks at Five Corners”.

CARRIED

2019-F/A-041

It was MOVED and SECONDED

THAT the Finance and Audit Committee:

1. Endorses Option 3 as outlined in the corporate report regarding the rainbow crosswalk(s) at five Corners and directs staff to review incorporating a rainbow path (covered in thermal plastic material) into the study/completion of the Five Corners plaza plan with the possibility of pedestrianizing the small stretch of Johnston Road between Pacific Avenue and Beachview Avenue so there is a proper plaza to use for events; and
2. Directs that this project be brought to the upcoming Community Forum, regarding Community Amenity Contributions for consideration of (CAC’s) funds to be used for the project.

CARRIED

Note: the advantages to doing this include, less need for security, with no vehicle traffic the paint will last longer on the pathway and to enhance a plaza Community Amenity Contribution funds can be utilized and not general revenue.

3.2 LIGHTING OUTSIDE OXFORD WATER FACILITY FENCE

Corporate report dated December 9, 2019 from the Director of Engineering and Municipal Operations titled “Lighting Outside Oxford Water Facility Fence”.

2019-F/A-042

It was MOVED and SECONDED

THAT the Finance and Audit Committee receives for information the corporate report dated December 9, 2019 from the Director of Engineering & Municipal Operations titled “Lighting Outside Oxford Water Facility Fence”.

CARRIED

2019-F/A-043

It was MOVED and SECONDED

THAT the Finance and Audit Committee endorses the inclusion of \$32,000 in the Draft 2020 to 2024 Financial Plan to install lighting outside of the new fence at the south west corner of the Oxford Water Facility.

- **Action:** Can CAC's be utilized for this? Staff will have to review this
- Is there funds to cover this? There is funds in the water reserve fund for this.
- Can motions sensors be placed on the lights? Yes on the flood lights and the new proposed lights too
- There was feedback on the floodlight and residents did not appear to like that
- **Action:** Concern with light pollution, is there a way not only have a sensor but is there an alternative (guidelines to keep the light pollution low)? Staff noted that these lights do have the hoods, but staff will check out the information

2019-F/A-044

It was MOVED and SECONDED

THAT the Finance and Audit Committee directs before this improvement be considered that there be a public process where the residents impacted will have opportunity to speak to it in public, and that this item be allocated to an upcoming agenda to have some public comments; letters are to go out to the nearby property owners to inform of this public comment opportunity.

CARRIED

Councillor Father voting in the negative

Action: it was stated that at the public comment opportunity for the budget this can be a highlighted items that the nearby residents can be invited to speak on this matter (letter will be sent to the 100 m radius.

3.3

ACCESSIBILITY UPGRADES AT CITY FACILITIES

Corporate report dated December 9, 2019 from the Director of Engineering and Municipal Operations titled "Accessibility Upgrades at City Facilities".

2019-F/A-045

It was MOVED and SECONDED

THAT the Finance and Audit Committee receives for information the corporate report dated December 9, 2019 from the Director of Engineering & Municipal Operations titled "Accessibility Upgrades at City Facilities".

CARRIED

2019-F/A-046

It was MOVED and SECONDED

THAT the Finance and Audit Committee endorses inclusion in the Financial Plan of \$50,000 per year over 4 years for accessibility upgrades at City Facilities.

CARRIED

The Committee noted that it should be staff's goal to ensure that any applicable grants are to be applied for.

3.4

BLEACHER SEATING FOR THE 2020 REMEMBRANCE DAY CEREMONY

Corporate report dated December 9, 2019 from the Director of Recreation and Culture titled “Bleacher Seating for the 2020 Remembrance Day Ceremony”.

2019-F/A-047

It was MOVED and SECONDED

THAT the Finance and Audit Committee receives for information the corporate report dated December 9, 2019 from the Director of Recreation and Culture titled “Bleacher Seating for the 2020 Remembrance Day Ceremony”.

CARRIED

2019-F/A-048

It was MOVED and SECONDED

THAT the Finance and Audit Committee recommends that Council support portable aluminum bleachers on city property as outlined in this corporate report, and consider including \$2,000 in the City’s 2020-2024 Financial Plan to fund the rental, installation and delivery of 480 portable aluminium bleacher seats for the 2020 Remembrance Day Ceremonies held in White Rock.

CARRIED

3.5

2020 TO 2024 DRAFT FINANCIAL PLAN – GENERAL FUND OPERATING BUDGET

Corporate report dated December 9, 2019 from the Director of Financial Services titled “2020 to 2024 Draft Financial Plan – General Fund Operating Budget”.

The Director of Financial Services gave a PowerPoint presentation regarding the City’s Financial Plan.

Meeting Recess / Meeting Reconvened

The Chairperson called a recess at 6:14 p.m. stating the meeting would reconvene in 30 minutes.

The Chairperson reconvened the meeting at 6:46 p.m. with all noted Council and staff members in attendance.

Discussion ensued regarding the Director of Financial Services presentation in regard to the General Fund Operating Budget:

- **Action:** Safety tickets vs. Non Safety tickets, what is the percentage ratio of that? Staff will provide this information
- Legal Fees and the increase of 35,000, what is the budget for legal fees? Staff noted \$2019 = \$325,000 and for 2020 \$360,000
They seem high is there anything there that we can do to get the cost down? Staff noted this is difficult as you don’t know what you will be faced with as a municipality (every city has unique issues). We do require some contingency in the operating plan.

Action: Are the City's fees comparable to other municipalities of similar size?
Staff will bring forward findings as to what other municipalities are spending in this regard

Can the City's legal firm be asked to reduce these costs? Would like to see other options.

- **Action:** Parking fines: Do we have difficulty in collection and what is the recovery cost?. The City has a system after a time the unpaid fee is sent to a collection agency. Staff will have to report back in regard to recovery cost.
- Funds not used in 2019, they are rolled over to 2020 in some cases some of the funds have been spent, staff wait until the end of the year and then the transfer will be made once all expenditures are in.
- Rail relocation funds not used in four (4) years, it was clarified by staff that White Rock and the City and Surrey do have funds set aside we are waiting for the Province and Federal government at this point. It is wise to keep the funds in a reserve so when the opportunity arises the City is ready (advantage of keeping them in you must have it in the budget to legally spend it).
- Funding for the Snowbirds seems high at \$30,000, staff clarified that \$10,000 of that goes toward the CHILD Foundation as a required donation for the Snowbirds to perform
- Reserve funds, Appendix A shows what goes in the reserve funds and what is allocated of the to capital projects
- Perfect Mind program progress? It was noted that it is well underway, due to launch the registration and facility booking program in March 2020

2019-F/A-049

It was MOVED and SECONDED

THAT the Finance and Audit Committee supports the Regular Full-Time Project Engineer staff position be placed in the budget at \$45,000; with the funding source to come from a combined reduction in contribution to capital and the capital reserves.

CARRIED

2019-F/A-050

It was MOVED and SECONDED

THAT the Finance and Audit Committee supports there be reinstatement of the Purchasing Officer staff position in the budget for \$64,000, with the funding source to come from a combined reduction in the City's legal budget by \$20,000 and the remaining funds by a property tax increase.

CARRIED

Councillors Manning and Trevelyan voted in the negative

Note: This item was a suggestion by the City's Auditors, KPMG

2019-F/A-051

It was MOVED and SECONDED

THAT the Finance and Audit Committee supports Additional Bylaw Enforcement staffing hours for \$30,000 to be added into the general fund operating budget.

CARRIED

Councillors Chesney, Manning and Trevelyan voted in the negative

Note: It is anticipated that this can be covered for by business license revenue, recent

fine increases and ensuring out of town contractors are obtaining a City business licence.

2019-F/A-052

It was MOVED and SECONDED

THAT the Finance and Audit Committee supports conversion of the Temporary Full-Time Committee Clerk position to Regular Full Time in the amount of 34,400 be added into the general fund operating budget.

CARRIED

Councillors Trevelyan voted in the negative

Discussion Ensued:

- **Action:** There was in inquiry regarding Police Officers per capita and how does the City's compare to neighbouring municipalities, staff to report back on this. The Mayor noted this in an important issue, would like to watch what occurs the next six (6) months to year with the anticipated changes to come by the City of Surrey in regard to policing
- Buskers Festival, was the Business Improvement Association (BIA) not funding that? There are two (2) parts to the festival, the BIA contribute to the comedy portion of the festival
- Municipal Operations Budget Increase, the City supports the events but there is a cost and pressure on the municipal operations along with this
- Part-Time Special Events Assistant, with the number of events has been a challenge, the coordinator by this time has logged 100 hours of overtime

Action: Staff will get back to the cost for 100 hours of overtime (it was noted that in regard to 100 hours per week it equates to 2 hours per week).

2019-F/A-053

It was MOVED and SECONDED

THAT the Finance and Audit Committee endorses a Part-Time Special Events Assistant at a cost of \$42,100 be added into the general fund operating budget

CARRIED

Councillor Chesney Johanson and Trevelyan voted in the negative

2019-F/A-054

It was MOVED and SECONDED

THAT the Finance and Audit Committee endorses the municipal operations budget increase needed to support the level of special events planned for 2020 at a cost of \$18,500 be added into the general fund operating budget

CARRIED

Councillor Trevelyan and Mayor Walker voted in the negative

Discussion Ensued:

- It was noted at this time that Council needs to talk about their Corporate Priorities before the budget is finalized. There is concern that this budget is being done "piece meal". Council needs to step back and look at what they want to do and ensure those areas are funded correctly (budget should be set around the Council Priorities).

2019-F/A-055

It was MOVED and SECONDED

THAT the Finance and Audit Committee endorses a new Regular Full-Time Trades Gardener staff position in the amount of \$93,800 be added into the general fund operating budget.

CARRIED

Councillors Chesney and Trevelyan voted in the negative

Discussion Ensued:

- Can Community Amenity Contributions be used to beautiful walkways and boulevards? Staff noted they can only be used for capital items, not operating expenses however you can upgrade a park with these funds
- Would like to see establishing a core volunteer group of gardeners

2019-F/A-056

It was MOVED and SECONDED

THAT the Finance and Audit Committee endorses a budget increase for Improvement Hillside Walkway Maintenance in the amount of \$30,000 be added into the general fund operating budget.

CARRIED

Councillors Chesney and Trevelyan voted in the negative

2019-F/A-057

It was MOVED and SECONDED

THAT the Finance and Audit Committee endorses a budget increase to Purchase of Various Materials, such as Perennials and Annuals in the amount of \$40,000 be added to the general fund operating budget.

CARRIED

Councillors Trevelyan and Mayor Walker voted in the negative

2019-F/A-058

It was MOVED and SECONDED

THAT the Finance and Audit Committee endorses the budget be maintained at the current annual level of funding in the amount of \$5,000 for the South Surrey / White Rock Chamber of Commerce.

CARRIED

2019-F/A-059

It was MOVED and SECONDED

THAT the Finance and Audit Committee directs staff to find creative ways to get the amount of the proposed budget increase lower; during the next stage of the budget process all items that the Committee has supported at this meeting are to include funding sources (other funding sources, possible use of reserve funds).

CARRIED

2019-F/A-060

It was MOVED and SECONDED

THAT the Finance and Audit Committee endorses an increase to the annual grant to the White Rock Museum and Achieves Society in the amount of \$25,000 be added to the general fund operating budget.

CARRIED,

Councillors Chesney and Trevelyan voted in the negative

Discussion Ensued:

- In regard to one time requests for the Development of a Heritage Home Inventory (\$110,000) and the Development of a Heritage Strategy (\$80,000) the amounts appear high, do not think the Committee who brought the recommendations forward were expecting that. There could be other ways to achieve these and there may be grant opportunities for this work.

2019-F/A-061

It was MOVED and SECONDED

THAT the Finance and Audit Committee directs staff to review the City of Port Coquitlam’s budget model, which incorporates their Council’s Corporate Priorities, to see if that method of presenting the budget with the established Corporate Priorities can work for the City of White Rock.

CARRIED

2019-F/A-062

It was MOVED and SECONDED

THAT the Finance and Audit Committee directs staff to review and identify what must be done in order to get the tax rate down to 2.9%, for information purposes, and include suggestions as to where possible savings can be found.

CARRIED

Councillor Fathers voted in the negative

The following 2020 to 2024 Financial Plan Proposed Schedule was noted:

Dec 9 & 12	Draft to be presented to the Finance and Audit Committee
Feb 3	Follow up on F & A Committee feedback – Staff to report back
Feb 10	F & A Committee Public Meeting Committee to give staff direction on amendments to be made
Feb 24	1 st 3 readings of FP Bylaw, Fees & Charges Bylaw & Utility Rate Bylaws
Mar 9	Adoption of FP Bylaw and above fee bylaws
Apr 20	Final amendments to be introduced to Council (eg. capital & operating budget project carry-overs, impact of final BC Assessment property values etc.)
Apr 27*	Public Meeting on amended FP Council to give direction on further amendments
May 4	1 st 3 readings of Amended FP Bylaw & Property Tax Rates Bylaw
May 11*	Adoption of FP & Property Tax Rate Bylaws (must be in that order)

MEETING CONCLUDED / A FURTHER MEETING CALLED

The Chairperson declared the December 9, 2019 Finance and Audit Committee meeting concluded at 9:12 p.m. and noted the remainder of the items will be addressed at a further Finance and Audit Committee meeting called for Thursday, December 12, 2019 at 5:00 p.m. to be held in the City Hall Council Chambers.

Note: Items 3.6 – 3.9 from this agenda will be brought forward to the December 12, 2019 Finance and Legislation Committee meeting

- 3.6. **2020 TO 2024 DRAFT FINANCIAL PLAN – GENERAL FUND ASSET IMPROVEMENT BUDGET**
3.7 **2020 TO 2024 DRAFT FINANCIAL PLAN – WATER UTILITY**
3.8. **2020 TO 2024 DRAFT FINANCIAL PLAN – DRAINAGE UTILITY**
3.9 **2020 TO 2024 DRAFT FINANCIAL PLAN – SANITARY SEWER UTILITY**

4. **ADJOURNMENT OF THE DECEMBER 9, 2019 FINANCE AND AUDIT COMMITTEE MEETING TO DECEMBER 12, 2019.**

The Chairperson declared the meeting concluded at 9:12 p.m.

4.1 **RECONVENE THE FINANCE AND AUDIT COMMITTEE MEETING ON DECEMBER 12, 2019 AT 5:00 P.M.**

The meeting reconvened at 5:00 p.m. on December 12, 2019 with the same Members of Council present and the following staff:

- D. Bottrill, Chief Administrative Officer
- S. Kurylo, Director of Financial Services
- J. Gordon, Director of Engineering and Municipal Operations
- S. Johnston, Manager of Budgets and Accounting
- D. Kell, Manager of Communications and Government Relations
- S. Lam, Deputy Corporate Officer

One (1) member of the public was present in the gallery.

Note: Items 3.6 – 3.9 from this agenda were brought forward.

3.6 **2020 TO 2024 DRAFT FINANCIAL PLAN – GENERAL FUND ASSET IMPROVEMENT BUDGET**

Corporate report dated December 9, 2019 from the Director of Financial Services titled “2020 to 2024 Draft Financial Plan – General Fund Asset Improvement Budget”.

The Director of Financial Services introduced the report through a PowerPoint presentation.

Staff provided the following comments in response to the Committee’s discussion/questions:

- “Community Amenity Contribution (CAC) Reserve (Non Statutory)” is CAC monies collected by the City prior to implementing the existing policy. Legal Counsel advised that a separate reserve fund be established to hold the funds. All of these funds are committed towards Memorial Park

- The \$100K towards the “Buena Vista Rental Property Reserve” is allocated towards the demolition of the existing structure, as well as any improvements possible to the extent of the budget

Discussion ensued with respect to the West Beach Wharf project, and the following comments were noted:

- If, in theory, the project were approved what would be the timeline for completion? It was estimated that it could take 3-4 months for design/contract, and approximately another 4 months for construction. These are estimations only.
- The project would need to be completed in 2020. If the project is not complete in time, grant funding could be lost. It was suggested the monies could be better spent elsewhere if there is a risk.
- The Committee spoke to removing this item from the budget. It was noted that leaving this item in the budget provides the City flexibility and the opportunity to receive \$330K in insurance. If the City removes this from the budget, only the cost of materials for the damages would be reimbursed. Staff advised they would report back with the estimated figure if only the materials were returned.
- If the City removes this item from the budget, the funding would return to the CAC reserve for other CAC eligible projects
- Staff advised they could see if an extension could be granted on the deadline and report back.

The Committee requested further clarification with respect to why a cut to capital projects does not impact property taxes. Staff noted:

- Saving on property taxes requires a reduction to something that is permanent (eg: operating, capital is one time projects)

2019-F/A-063

It was MOVED and SECONDED

THAT the Finance and Audit Committee recommends that \$600K allocated towards the Wharf Project be removed from the Financial Plan for this year.

DEFEATED

Councillors Chesney, Fathers, Johanson, Trevelyan, and
Mayor Walker voted in the negative

The Committee questioned the lifespan of garbage trucks and staff advised that they can function between 8 to 10 years, adding that there are many moving parts and components to keep them working properly. It was noted that the City is trying to keep them operating until the Solid Waste Study is complete. It was also noted that in-house staff/mechanics do a good job maintaining vehicles, but that sometimes parts are hard to obtain or have manufactured. Property taxes are not impacted by solid waste as it is generally funded by the solid waste user fee.

The meeting recessed at 6:02 p.m. and reconvened at 6:36 p.m. with all of the same members of staff and the Committee present.

The Committee spoke to the proposed Pickleball courts at Maccaud Park, and expressed concerns for removing greenspace. It was suggested that an alternate place along the waterfront (eg: dog park or the parking lot along Bayview park), may be a better suited location adding that it could be another attraction for people to visit White Rock. It was also noted that a delegation came before Council requesting basketball courts be installed in the City. It was noted that school-grounds often have basketball courts that are publically accessible when class is not in session.

2019-F/A-064

It was MOVED and SECONDED

THAT the Finance and Audit Committee recommends that the Pickleball project, estimated at \$500K, be removed from the Maccaud park upgrade.

CARRIED

Councillor Johanson and Mayor Walker voted in the negative

2019-F/A-065

It was MOVED and SECONDED

THA the Finance and Audit Committee recommends that staff continue to explore options for pickleball courts in the community (basketball /pickleball) and the financial plan could be amended later if needed.

CARRIED

The Committee spoke to the All Abilities Park project led by the Firefighters, noting that their desire is to have it located along East Beach.

It was suggested that any courts or parks built should be constructed on City owned land.

Community Amenity Contributions (CAC)

Discussion ensued regarding CACs, and the following comments were noted:

- CAC agreements are negotiated and determined between the City and the Developer
- CACs are a one-time contribution to the City, and is not an ongoing revenue stream
- Suggested CACs be allocated towards the installation of bus shelters

2019-F/A-066

It was MOVED and SECONDED

THAT the Finance and Audit Committee allocate funds in the budget for the installation of bus shelters.

CARRIED

Staff will follow up with respect to the location of shelters, particularly with respect to one located on the west side of Russell Avenue along Johnston Road.

2019-F/A-067

It was MOVED and SECONDED

THAT the Finance and Audit Committee:

1. Receives for information the corporate report dated December 9, 2019, from the Director of Financial Services, titled “2020 to 2024 Draft Financial Plan – General Fund Asset Improvement Budget”;
2. Endorses the presented Draft Financial Plan figures and assumptions for the General Fund Asset Improvement Budget or provide direction on amendments to be made.

CARRIED

Moving forward the Committee noted that they would like to have a spreadsheet or document that gives a breakdown/explanation with respect to costs of general governance/operations (eg: insurance, contingency, freedom of Information, etc) for all departments.

3.7

2020 TO 2024 DRAFT FINANCIAL PLAN – WATER UTILITY

Corporate report dated December 9, 2019 from the Director of Financial Services titled “2020 to 2024 Draft Financial Plan – Water Utility”.

The Committee questioned the status of the Water Utility’s filtration system. Staff advised that the filters have aged quicker than anticipated and that the City is working with the contractors to have the issue dealt with. Once the information is available, staff will report back.

2019-F/A-068

It was MOVED and SECONDED

THAT the Finance and Audit Committee:

1. Receives for information the corporate report dated December 9, 2019, from the Director of Financial Services, titled “2020 to 2024 Draft Financial Plan – Water Utility;”
2. Endorses the presented Draft Financial Plan figures and assumptions for the Water Utility or provide direction on amendments to be made; and

CARRIED

Councillor Kristjanson voted in the negative

- 3.8. 2020 TO 2024 DRAFT FINANCIAL PLAN – DRAINAGE UTILITY**
Corporate report dated December 9, 2019 from the Director of Financial Services titled “2020 to 2024 Draft Financial Plan – Drainage Utility”.

2019-F/A-069

It was MOVED and SECONDED

THAT the Finance and Audit Committee:

1. Receives for information the corporate report dated December 9, 2019, from the Director of Financial Services, titled “2020 to 2024 Draft Financial Plan – Drainage Utility”;
2. Endorses the presented Draft Financial Plan figures and assumptions for the Drainage Utility or provide direction on amendments to be made.

CARRIED

- 3.9 2020 TO 2024 DRAFT FINANCIAL PLAN – SANITARY SEWER UTILITY**

Corporate report dated December 9, 2019 from the Director of Financial Services titled “2020 to 2024 Draft Financial Plan – Sanitary Sewer Utility”.

In response to the Committee’s question, staff advised that Metro Vancouver is conducting significant upgrades to different parts of their sanitary sewer system/treatment plants. It was reported that they are moving towards having all their plants to a secondary treatment level. These upgrades will have improvements and benefits to the environment, and in turn – the City of White Rock.

2019-F/A-070

It was MOVED and SECONDED

THAT the Finance and Audit Committee:

1. Receives for information the corporate report dated December 9, 2019, from the Director of Financial Services, titled “2020 to 2024 Draft Financial Plan – Sanitary Sewer Utility”;
2. Endorses the presented Draft Financial Plan figures and assumptions for the Sanitary Sewer Utility or provide direction on amendments to be made.

CARRIED

The Committee spoke to the desire and earlier motion to reduce the proposed property tax increase to 2.9%. Staff advised that they would prioritize items that may be reduced for consideration.

2019-F/A-071

It was MOVED and SECONDED

THAT the Finance and Audit Committee directs staff to identify items in the operating budget that can be reduced.

CARRIED

Councillor Chesney and Fathers voted in the negative

**4. CONCLUSION OF THE DECEMBER 9, 2019 FINANCE AND AUDIT
COMMITTEE MEETING**

The Chairperson declared the meeting concluded at 8:14 p.m.

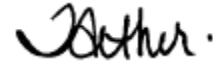

Councillor Johanson
Chairperson

Tracey Arthur, Director
Corporate Administration

UNAPPROVED

PRESENT: B. Cooper, Vice-Chairperson
E. Dufour
Y. Everson
G. Kennedy
B. West
U. Maschaykh

ABSENT: J. Adams, Chairperson

STAFF: E. Stepura, Director of Recreation and Culture
C. Isaak, Director of Planning and Development Services (left at 4:50 p.m.)
E. Keurvorst, Manager of Cultural Development
E. Tuson, Committee Clerk

Public: 2
Press: 0

1. CALL TO ORDER

The meeting was called to order at 4:07 p.m.

2. ADOPTION OF AGENDA

2019-PAAC-008

IT was MOVED and SECONDED

THAT the Public Art Advisory Committee (the Committee) adopts the agenda for the November 28, 2019 meeting as circulated.

CARRIED

3. ADOPTION OF MINUTES

a) September 26, 2019

2019-PAAC-009

IT was MOVED and SECONDED

THAT the Public Art Advisory Committee (the Committee) adopts the minutes of the September 26, 2019 meeting as circulated.

CARRIED

4. 1350 JOHNSTON ROAD – MURAL PROJECT

D. Austerberry, Development Manager, and K. Labow of Durante Kreuk Ltd., public art consultants, provided a presentation regarding the mural project for 1350 Johnston Road (the Monaco building). An On Table summary addressed the general scope of the mural project.

D. Austerberry and K. Labow provided the following information:

- The canvas for the mural is “C” shaped along the side of the building. Giving the artists creativity and potential to occupy the space.
- Selection of the artist:
 - A selection panel will be comprised to select the artist and coordinate with the City as necessary.
 - The selection panel provides transparency in selecting the artist, and adheres to the public art process.
 - The selection process will include an invitational call to artists. Each panelist on the selection panel will put forward three (3) to five (5) artists to be considered. Through a voting process, a short list of artists would be comprised (approximately three (3) will be selected, with a few in reserve). Short listed artists will be invited to generate concepts. The artists will be given an opportunity to develop/ explain their concepts to the selection panel.
- The selected Artist will be in charge of managing project costs and getting the work installed.
- Mural maintenance is operated by the building strata. Public art contracts typically include maintenance by the Strata and ability for the artist to have some decision making power.

The Director of Planning and Development Services noted that there is an existing Lane on the East side of the property. This allows for access to the parkade.

In response to a question from the Director of Recreation and Culture, D. Austerberry noted that they are open to having a panelist representative from the Public Art Advisory Committee. They are open to recommendations on how to construct the panel that reflect the needs and wants of the City of White Rock.

The Committee discussed the possibility of having the mural be moveable in the case that surrounding areas get developed and the mural is no longer viewable. The Director of Planning and Development Services noted that due to combustibility issues, the City does not allow flammable or combustible material to be located that close to property lines.

The Committee provided the following comments:

- Environmental contributions (e.g. sun exposure, moss etc.) need to be considered in terms of damage to the art work. The mural will need to be replaced in 10-15 years due to these conditions.
- Concerns were expressed regarding the \$24,000 budget for the mural. In response, D. Austerberry noted that they reached out to muralists for quotes to perform murals on space of comparable size. The highest quote received was increased by 30% to obtain the budget of \$24,000.
- Staff confirmed that any committee members on the panel or city staff would not receive an honorarium for sitting on the selection panel. It would be an external member not directly involved in the project or working on behalf of

the City who would receive an honorarium. This practice is supported by the City's Public Art Policy.

- Due to budget constraints, having the mural done on a non-combustible, removable surface would not be practical.
- Photography artists could be considered, as long as they understand how to apply the photograph to the mural space.
- The budget may limit the kinds of materials and process that can be used.

Note: D. Austerberry and K. Labow exited the meeting.

In response to questions from the Committee, staff noted that Council wishes to encourage more participation and inclusion of local artists (White Rock, South Surrey, or Semiahmoo First Nations). A public art project that is \$75,000 and above needs to be an open public selection process. Since this particular mural only has a budget of \$24,000 it would be Council's preference to select a local artist; however, the decision will be up to the Selection Panel as laid out in the Public Art Policy.

2019-PAAC-010

IT was MOVED and SECONDED

THAT the Public Art Advisory Committee (the Committee) receives the mural project for 1350 Johnston Road (the Monaco building) presentation for information.

CARRIED

2019-PAAC-011

MOVED and SECONDED

THAT the Public Art Advisory Committee (the Committee) nominates the following member to represent the Committee on the 1350 Johnston Road – Mural Project Selection Panel:

- U. Maschaykh.

CARRIED

The Committee indicated that seeing as Ms. Maschaykh also represents the Semiahmoo Arts Society, they would like to provide the following comments to the public art consultant as they consider the remaining membership of the selection panel:

- That a representative from Semiahmoo First Nation, with a preference for a Semiahmoo Artist, be on the art selection panel.
- That instead of another community representative at large, it be a community/local artist representative.
- That the Manager, Cultural Development sit on the panel as a non-voting member.

Acton Item: Staff to meet with the Developer's Public Art Consultant, to discuss the Committees comments and recommendations regarding the selection panel.

5.

PUBLIC ART MAPPING

The Manager of Cultural Development to provide an update on the City's public art mapping in January 2020.

6. **ART DONATION TO THE CITY FROM THE SPIRITUAL ASSEMBLY OF THE BAHAI'S OF WHITE ROCK**

The Director of Recreation and Culture provided information on an art donation titled *Gates of Paradise* presented to Mayor and Council from the Spiritual Assembly of the Bahá'ís of White Rock at the October 21st Council meeting.

Note: The Public Art Policy 708 is included for reference: Item 7 – Acquisition, Commissioning or Accepting Gifts of Public Art.

Staff provided the following information:

- The Piece was given to Council as a gift from a faith based group in the community.
- Council suggested the piece of art be hung in Council Chambers.
- Research shows that the piece reflects Bahá'í religious symbolism.
- Much of the City's permanent art collection is in storage in an environmentally controlled vault in the White Rock Museum and Archives.
- The Committees Terms of Reference notes that the Committee will advise Council on the acceptance of art into the City's permanent collection.

The Committee referred to the Public Art Policy for guidance in order to provide Council with advice regarding the acceptance of the *Gates of Paradise* art piece.

The Committee pointed to the Public Art Policy section 7-E (Gifts, Donations and Bequests) for accepting artwork into the permanent collection. Specifically concerns were expressed regarding storage, presentation and the precedent of accepting gifts with religious symbolism.

The Committee discussed the idea of a multi-faith art showcase produced at the Gallery at the White Rock Community Centre. This would give the Assembly of the Bahá'ís of White Rock an opportunity to display it on a temporary basis; while, also allowing other faith groups in the community the opportunity to participate. U. Maschaykh noted that the Semiahmoo Arts Society would be pleased to work with the City to coordinate such a showcase in the near future.

2019-PAAC-012

IT was MOVED and SECONDED

THAT the Public Art Advisory Committee (the Committee) recommends that, in keeping with the Public Art Policy, Council consider not accepting the art donation titled *Gates of Paradise* into the permanent City Collection; and,

THAT instead, the gift be showcased in a multi-faith themed art showcase.

CARRIED

7. **PAAC WORK PLAN 2019-2020**

Review of the Public Art Policy – 708

The following was noted:

- Council has expressed their desire to encourage more participation and inclusion by local artists during the public art selection process.
- For any procurement where the value is equal or greater than \$75,000, the following trade agreements apply and must be adhered to:
 - Northwest Partnership Trade Agreement.
 - Canadian Free Trade Agreement.
- If the Committee approves of the amendment, it will be included in Policy 708 – Public Art.

The Committee discussed potential amendments to Policy 708. It was noted that local artists have always been invited to apply. Committee members reiterated that the goal of the public art program is to select the best artist and art work relevant to the public art call. This often means selecting media and large scale formats that are not practiced by artists locally.

2019-PAAC-013

IT was MOVED and SECONDED

THAT the Public Art Advisory Committee (the Committee) recommends amending Policy 708 – Public Art, under section 3.1 (City Public Art Program) to include the following as an additional item f):

- When calling for artists, the selection committee will endeavor to select, where possible, local artists from White Rock, South Surrey, or Semiahmoo First Nations.

CARRIED

2019-PAAC-014

IT was MOVED and SECONDED

THAT the Public Art Advisory Committee (the Committee) approves the Public Art Policy 708 as amended.

CARRIED

Review of the Strategic Placement of Public Art Plan

The Committee discussed priority locations for placement of public art.

The Committee noted that the City's public forum regarding Town Center planning will have recommendations coming from the consultant. These recommendations will help the Committee move forward with their public art process.

Action Item: Invite C. Isaak, Director of Planning and Development Services to attend the January meeting and provide the Committee with an update on the Town Centre planning process.

Action Item: Staff to devote the January meeting to receiving information from C. Isaak and conduct a visioning session with the Committee. Committee members to bring back ideas/ visions for opportunities for more engagement and art in the community.

Action Item: Staff to send out the missing page from the agenda to the Committee for information.

Staff noted that the Committee's work plan should also include a selection of a public art piece on the corner of Thrift Street and Johnston Street.

Action Item: Staff to report back to the Committee regarding a public art call for an art piece on the corner of Thrift Street and Johnston Street.

Banners and Sidewalks

Staff noted that the banner program used to be run by the White Rock Business Improvement Association (BIA). It is now the City's responsibility. A reusable print for the entire City is roughly \$18,000 - \$20,000. The creation of new street banners may be a good way to engage local artists in a public art initiative.

Staff will bring back information and a proposal to the Committee regarding a public art call to local artists for the creation of new street banners.

Action Item: Staff to share information about the Port Moody banner festival with the Committee.

8. NEW BUSINESS

Staff noted that the White Rock Pride Society previously appeared as a delegation to Council, they have asked rainbow crosswalks at all three (3) corners of 5 Corners. The Engineering and Municipal Operations Department is pricing out the cost of doing two (2) additional crosswalks. This will be included in the City's five (5) year financial plan.

9. PUBLIC ART ADVISORY COMMITTEE 2020 MEETING SCHEDULE

2019-PAAC-015

IT was MOVED and SECONDED

THAT the Public Art Advisory Committee approves the 2020 meeting schedule as follows:

- January 30
- February 27
- March 26
- April 23
- May 28
- June 25
- July 30
- September 30
- October 29
- November 26

CARRIED

10. CONCLUSION OF THE NOVEMBER 28, 2019 MEETING

The Chairperson concluded the meeting at 5:57 pm.

B. Cooper
Vice-Chairperson

E. Tuson
Committee Clerk

PRESENT: R. Hynes, Chairperson
J. Lawrence, Vice-Chairperson
W. Boyd
P. Byer
S. Crozier
I. Lessner
D. Riley

COUNCIL: Councillor E. Johanson (non-voting)

STAFF: J. Gordon, Director of Engineering and Municipal Operations
S. Whitton, Parks, Manager
A. Claffey, Arboricultural Technician
D. Johnstone, Committee Clerk

Public: 1
Press: 0

1. CALL TO ORDER
The Chairperson called the meeting to order at 4:00 p.m.

2. ADOPTION OF AGENDA

2019-EAC-029 **It was MOVED and SECONDED**
THAT the Environmental Advisory Committee adopts the December 5, 2019 agenda as circulated.

CARRIED

3. ADOPTION OF MINUTES

2019-EAC-030 **It was MOVED and SECONDED**
THAT the Environmental Advisory Committee amends the minutes of the November 5, 2019 meeting as follows:

- Under Item 5 – Climate Emergency (page 3) the draft motion elements be amended to read:
 - Would declare a climate emergency; and,
 - Incorporate ideas/ wording from climate change proposed motions #3 and #4 #1-4.
 - ~~Request Council seek a corporate report with advise from staff and consultation with the Environmental Advisory Committee on the best way to proceed in terms of action; and,~~

THAT the minutes be adopted as amended.

CARRIED

It was MOVED and SECONDED

THAT the Environmental Advisory Committee permits a member of the public to speak.

CARRIED

A member of the public provided the committee with a brochure in relation to climate change for their information.

4. TREE MANAGEMENT BYLAW 1831 AND TREE MANAGEMENT ON CITY LANDS POLICY 611

Additional changes to Bylaw 1831 from Staff

Staff summarized the changes that were discussed at the November 5, 2019 meeting. In addition, staff suggested that a Type 4 (four) permit could be considered within Bylaw 1831 which could make it more user friendly for smaller projects with smaller fees and securities. This could act as a tree protection plan. The Committee debated if an additional permit would be helpful or more onerous for home owners. It was also noted that if the Type 4 (four) permit were to be introduced educating the public about this would be important.

Staff summarized their suggested changes for Tree Management on City Lands Policy 611.

The following discussion points were noted:

- Posting notices on trees that are to be removed was discussed. Staff noted that this process can delay removal time, and that often times the removal of high risk trees is not up for debate (safety concerns etc.).
- The definitions of *significant* and *high risk trees* were debated. It was suggested that this be made clearer so that the public is better able to understand the terminology.
- Tree replacement costs in Policy 611 have been amended to be consistent with Bylaw 1831.
- It is important to have a Bylaw and Policy that are able to withstand changes with staffing and Council.
- Establishing better criteria for any type of tree removal was suggested.
- With respect to the view provision, it was noted that the City has an objective to maintain and increase its tree canopy. Including this statement within the policy was encouraged.

The Committee discussed Section 6 (six) of Policy 611 – Applications to Permit the Pruning or Removal of a Tree on City Lands. Enquiries were made on why members of the public would remove a tree on city lands, and if this should be allowed. Staff noted that there were no changes made to this section because it is ultimately up to Council on how they want to address this issue. The Committee could still put forward recommendations with regard to this section if they so choose.

The effectiveness of Bylaw 1831 and Policy 611 were discussed by the Committee, particularly with respect to the tree canopy. Staff expressed the opinion that both documents are working; however, often times it is the Zoning Bylaw which can have an effect on trees. While the Zoning Bylaw may be out of the Committee's purview, it was suggested that the Committee could provide input into the Official Community Plan review with respect to environmental matters.

The Committee turned their discussion towards the sub-committee that was struck at the September 5, 2019 meeting to help assist with this topic. The Committee discussed the purpose of the current sub-committee. It was noted that members are working to collect and organize information and to provide that information back to the Committee as a whole for discussion. It was identified that this is more in line with the tasks of a working group.

2019-EAC-032 **It was MOVED and SECONDED**
 THAT the Environmental Advisory Committee rescinds motion 2019-EAC-010.
CARRIED

2019-EAC-033 **It was MOVED and SECONDED**
 THAT the Environmental Advisory Committee creates a working group to do further research and organize information relating to Tree Management Bylaw 1831 and Tree Management on City Lands Policy 611.
CARRIED

Working group members S. Crozier and I. Lessner volunteered to re-organize the information previously provided to include the feedback received by staff. Once this has been completed the Committee would review and provide comments/suggestions on each section.

5. CLIMATE EMERGENCY

Chairperson R. Hynes discussed his proposal titled "Updating and Strengthening White Rock's Engagement on Climate Change".

Discussion ensued, with the Committee providing the following comments:

- An updated chapter on climate change within the Official Community Plan was discussed. It was noted that this chapter could be referenced in other strategic policy documents, such as the Environmental Strategic Plan. This was identified as a way to streamline strategic processes.
- Action tracking components within strategic documents were discussed as a potential way to monitor progress.
- Enquiries were made on the Metro Vancouver targets for greenhouse gas reductions and if White Rock is required to adopt the same targets. Staff noted that the City would want to work within Provincial targets as this is important when applying for grants etc.

2019-EAC-034

It was MOVED and SECONDED

THAT the Environmental Advisory Committee endorses the proposal titled “Updating and Strengthening White Rock’s Engagement on Climate Change.”

CARRIED

2019-EAC-035

It was MOVED and SECONDED

THAT the Environmental Advisory Committee requests that Council:

Joins other jurisdictions of Metro Vancouver in recognizing the “climate emergency” arising from critical threats that climate change poses on multiple fronts to regional ecosystems, city infrastructure and the well-being of White Rock’s citizens,

Declares its determination to ensure that the critical interests of White Rock and its citizens are protected and advanced in the fullest possible measure through the City’s climate change mitigation and adaptation strategies,

Requests the Environmental Advisory Committee, working with staff:

- (a) In the context of its mandated review of the Environmental Strategic Plan, to give priority consideration to that Plan’s climate change-related elements, and in so doing to consider also the 2010 Community Climate Action Plan and climate change-related elements of the 2017 OCP.
- (b) To recommend updated emission reduction targets, aligned with targets established by Metro Vancouver in July 2019, and consistent with current provincial and federal goals and the latest IPCC work.
- (c) To recommend steps, including appropriate public consultation measures, to ensure that the City’s climate change goals, policies and actions are updated and consolidated into the Official Community Plan as part of the ongoing OCP review exercise.

Directs staff to:

- (a) Ensure that climate change mitigation and adaptation considerations are mainstreamed into decision-making and operations across all City departments and that climate change impact assessments expressly figure in all reports and recommendations to Council,
- (b) Keep Council apprised of work by Metro officials and committees to develop regional Climate 2050 Roadmaps, and of opportunities and requirements to ensure the City’s interests and perspectives are taken into account in the Roadmaps process,
- (c) Advise Council of any organizational, human resource or financial requirements deemed necessary to ensure the effective implementation of this resolution, as well as opportunities to take advantage of regional, provincial and extra-

governmental resources available to inform and support our climate change efforts,

- (d) Keep Council regularly informed of progress in the implementation of this resolution, including through briefings on the City's annual reports to the Province's Climate Action Revenue Incentive Program (CARIP).

CARRIED

Action Item: Staff to provide the Committee with information on where the funds from the Climate Action Revenue Incentive Program (CARIP) are allocated in the City and how these funds can be utilized in the future.

6. SEMIAHMOO BAY WATER QUALITY

The Committee discussed their recommendation to Council to invite a member from the provincial government to an upcoming meeting. It was noted that the purpose of the invitation would be to obtain information on what the objectives/ priorities of the province are, how they are implemented, how they are planning to work with municipalities on these objectives and future plans for the Wildlife Management area. Water quality was noted as one concern, but the Committee also expressed an interest in discussing other environmental concerns such as wildlife management and drainage.

The Committee noted that finding a representative that could speak to these items as well as long term objectives would be preferred.

7. ORGANIZATION OF COMMITTEE WORK PLAN

At the October 24, 2019 meeting the Chairperson noted that there are a variety of items on the Committee's work plan that are still to be addressed by the Committee. It was suggested that the Committee discuss a method of organization/prioritization for the remaining items (Storm Water Management Plan, Environmental Strategic Plan, Pier referral document).

The Committee noted that currently there are working groups established for tree protection and water quality which will help with the organization of information. The Pier referral item from Council was identified as an item to be discussed at a later date.

8. OTHER BUSINESS

- It was noted that Council referred a presentation titled "Bee City White Rock" to the Environmental Advisory Committee for discussion. Staff noted that Mr. Thompson would be invited to a future Committee meeting.
- The Committee was provided with an updated copy of the Action Tracking document.

9.

ENVIRONMENTAL ADVISORY COMMITTEE MEETINGS

The following 2020 Environmental Advisory Committee meeting dates were approved by the Committee at the October 3rd meeting and are noted on the agenda for information purposes:

- January 9
- February 6
- March 5
- April 2
- May 7
- June 4
- July 2
- September 3
- October 8
- November 5

The Committee discussed the need for additional meetings in 2020.

2019-EAC-036

IT WAS MOVED AND SECONDED

THAT the Environmental Advisory Committee approves the following additional meetings for 2020:

- January 23;
- February 20;
- March 19;
- April 16;
- May 21;
- June 18;
- July 23;
- September 24;
- October 22; and,
- November 19.

CARRIED

13.

CONCLUSION OF THE DECEMBER 5, 2019 ENVIRONMENTAL ADVISORY COMMITTEE MEETING

The Chairperson declared the meeting concluded at 6:02 p.m.



R. Hynes, Chairperson

D. Johnstone, Committee Clerk



POLICY TITLE: MANAGING THE CITY OF WHITE ROCK'S SOCIAL MEDIA PRESENCE

POLICY NUMBER: COUNCIL - 136

<i>Date of Council Adoption:</i> April 16, 2012	<i>Date of Last Amendment:</i> July 27, 2015
<i>Council Resolution Number:</i> 2012-105, 2013 -082, 2015-285	
<i>Originating Department:</i> Administration	<i>Date last reviewed by the Governance and Legislation Committee:</i> July 13, 2015 December 10, 2018 , January 14, 2019

Formatted: Highlight

Formatted: Highlight

Policy:

1. The City of White Rock social media pages ~~shall~~ will be administered and approved ~~by the Communications Officer~~ Manager of Communications and Government Relations or ~~other designate~~ approved by the Manager of Communications and Government Relations ~~Communications Officer~~.
2. ~~The All~~ City of White Rock social media pages ~~shall~~ will comply with all applicable provincial, federal and local laws, regulations and policies including but not limited to the following City of White Rock Policies:
 - ~~a.~~ Respectful Workplace, Policy 405
 - ~~a.~~ Employee Code of Conduct, Policy 404
 - ~~b.~~ Correspondence Received by the City, Policy 107
 - ~~c.~~ Invitations to Mayor and Council, Policy 122
 - ~~d.~~ Corporate Vision, Mission and Values, Policy 101
3. Designated City of White Rock employees representing the city government ~~via on~~ social media outlets must conduct themselves at all times as a representatives of the City and in accordance with ~~all Human Resources policies~~ the Employee Code of Conduct, Policy 404.
4. ~~Social media usage must be in compliance with the BC Human Rights Code, BC Criminal Code, BC Freedom of Information and Protection of Privacy legislation, copyright and patent laws~~ The personal information posted on any of the social media and digital platforms used by the City of White Rock, may be collected by the City of White Rock under Section 26(c) of the British Columbia Freedom of Information and Protection of Privacy Act for the purposes of engaging and consulting with the public. Please note that the information collected may be

Formatted: Indent: Left: 0", First line: 0"

~~stored and/or accessed outside of Canada on servers not belonging to the City but belonging to host sites. Members of t~~The public can protect their privacy and the privacy of others by not including personal information such as phone numbers, email addresses, including personal photos of and information about others, in the body of their online comments.

5. All City of White Rock social media pages ~~shall will~~ clearly indicate ~~that~~ they are maintained by the City of White Rock and ~~shall will prominently display~~have City of White Rock contact information.

~~The pages will also indicate to users that they are prominently displayed. The City will also post a disclaimer informing users that they are providing personal information to the site and the City and that the City does not have ownership or control of the information because this information resides with the social media service. Please note that by participating on City of White Rock-related social media networks and you are subject to the Terms of Use of the host sites. (Examples of host sites are Facebook, Twitter, and Instagram, etc.) Information you shared with, or posted on, to official City of White Rock online engagement platforms are is also subject to the Terms of Use of the host site and may be used by the owners of the host sites for their own purposes. UTherefore, users should consult terms of use on the host website's Terms of Use. The City of White Rock mustsocial media moderators must also adhere tofollow the rules listed in the terms of use of host sites. the Terms of Use of host sites.~~

Formatted: Indent: First line: 0"

6. The City of White Rock's web-site (www.whiterockcity.ca) will remain the City's ~~primary and predominant~~leading internet presence. ~~Whenever~~ possible, content posted to City of White Rock social media pages will contain links directing users back to the City's official web-site for ~~in depth~~more information, forms, documents ~~and~~or online services.

7. All information ~~placed~~posted on social media pages is considered public information similar to ~~information that~~ published on the City of White Rock's web pages and must adhere~~follow~~ the host site's Terms of Use. Examples of host sites are ~~(i.e. Facebook, Twitter and Instagram.)~~.

8. Comments made by the public on City of White Rock social media pages are reviewed and, while comments will not be edited by designated City of White Rock employees, a comment may be deleted if it violates the comment policy described here:

- a. Comments should be related to the posted topic for the City of White Rock's ~~'s~~ social media page or post. City of White Rock social media accounts are not meant for comments that do not directly relate to the purpose or topic of the social media website or for service complaints.
- b. The City of White Rock's social media accounts are not open to comments promoting or opposing any person campaigning for election to a political office, or promotion or advertisement of a business.

~~b.c.~~ Repetitive posts copied and pasted or duplicated by single or multiple users will be deleted.

d. The City will delete posts, ~~Posts~~, comments or messages that are hateful, offensive or discriminatory, that use profane language or content, ~~or comments~~ that contain personal attacks, that encourage or incite hatred or violence or that reasonably compromise safety will be deleted.

e.e. The use of profane language or content is prohibited. ~~Filters will be applied on social media sites, where available.~~

f.f. The use of content that promotes, fosters or perpetuates discrimination on the basis of race, creed, colour, age, religion, gender, marital status, status with regard to public assistance, national origin, physical or mental disability or sexual orientation is prohibited.

g.g. Sexual content or links to sexual content is prohibited.

h.h. Conduct or encouragement of illegal activity is prohibited.

i.i. Information that may lead to compromise the safety or security of the public or public systems is prohibited.

j.j. Content that violates a legal ownership interest of any other party is prohibited.

9. The comment section of the policy is subject to amendment or modification at any time.

Rationale:

The City of White Rock encourages the use of social media to further enhance communications with citizens, local businesses and various stakeholder organizations in support of the City's goals and objectives. This policy provides a framework for public communication on behalf of the City of White Rock using social media tools. This policy is intended to ensure effective online communication while adhering to legal requirements.

Attachment A: Definitions

Social Media: Social media is content created by individuals using accessible and scalable technologies through the Internet. Examples of social media include Facebook, blogs, [MySpace](#), [RSS](#), You Tube, [Instagram](#), [Second Life](#), Twitter, LinkedIn, Flickr, ~~etc.~~

Blog: (an abridgement of the term web log) is a web-site with regular entries of commentary, descriptions of events, or other material such as graphics or video.

Author: A designated City of White Rock employee that creates and is responsible for posted articles and information on social media sites.

Article: An original posting of content to a social media site by a designated City of White Rock employee.

Commenter: A City of White Rock official or member of the public who submits a comment for posting in response to the content of a particular City of White Rock article or social media commenter.

City of White Rock Moderator: A designated City of White Rock employee, who reviews, authorizes and allows content submitted by City of White Rock authors and public commentators to be posted to a City of White Rock social media site.

THE CORPORATION OF THE
CITY OF WHITE ROCK
 15322 BUENA VISTA AVENUE, WHITE ROCK, B.C. V4B 1Y6



POLICY TITLE: PUBLIC ART

POLICY NUMBER: RECREATION AND CULTURE - 708

<i>Date of Council Adoption:</i> July 12, 2010	<i>Date of Last Amendment:</i> November 4, 2019
<i>Council Resolution Number:</i> 2010-347, 2013-134, 2014-152, 2015-285, 2016-302, 2019-498	
<i>Originating Department:</i> Recreation and Culture	<i>Date last reviewed by the Governance and Legislation Committee:</i> October 21, 2019

Policy:

Table of Contents

1. Introduction (Purpose, Principles, Goals).....	2
2. Definition of Public Art.....	4
3. Council’s Strategic Direction and Monitoring.....	4
4. Funding.....	5
5. Public Art Advisory Committee (PAAC).....	6
6. Public Art Selection Panel (PASP).....	7
7. Acquisition, Commissioning or Accepting Gifts of Public Art.....	8
8. Management of the Public Art Collection.....	9
9. Rationale.....	12
10. Community Consultation Process: Public Art on City Owned Retaining Wall.....	12
Appendix 1 - Selection Process.....	16
Appendix 2 - Public Art Definitions.....	21

1. **INTRODUCTION**

1. **Purpose**

The purpose of the Public Art Policy is to:

- a) Ensure public art continues to make the environment visually beautiful and reflects both White Rock's character and a broader cultural diversity.
- b) Ensure artwork and the creative concepts of artists are supported through the City's Public Art Program.
- c) Serve as an act of public trust and stewardship for public art.
- d) Establish a sustainable funding mechanism to support the City's commitment to public art.
- e) Guide City staff in the implementation of the Public Art program.

2. **Principles**

The Public Art Policy ensures that public art is:

- a) Selected through an informed, open and fair public art competition process and consideration is being given to local, regional and national artists.
Increasing public understanding, awareness and enjoyment of the arts in everyday life.
- b) Reflective of the diversity, values and history of the community to foster a sense of belonging, identity and place.
- c) Reflective of a wide range of professional artistic expression and practice, demonstrating excellence, quality and innovation.
- d) Responding to and enhancing the natural, social and built environment of the City of White Rock.
- e) A catalyst for creativity in White Rock's diverse community by providing opportunities for community engagement, development and partnerships.
- f) Stimulating economic and tourism development and presenting a positive image to visitors and potential investors.
Integrated into the planning, design and execution of applicable community/civic development.

3. **Goals**

The Public Art Program will include three distinct programs:

1. **City Public Art Program**

A consistent and key principle underlying the successful development and implementation of a City Public Art Program is the demonstration of leadership and commitment by the City in initiating and facilitating the creation of public art as an integral component of its city capital projects.

A Public Art Policy for the City will:

- a) Provide an impetus and flexible framework for incorporating public art, at the planning stages, into new or existing capital improvement projects by the City.
- b) Establish guidelines for accepting gifts/bequests of public art and for the deaccession of public artworks.
- c) Develop a stable funding mechanism to ensure that resources are available to create, preserve and inventory public artworks.
- d) Incorporate the ideas and work of various artists and artistic disciplines in the public realm.
- e) Advance capital project goals or other City objectives, such as economic development and tourism.
- f) **When calling for artists, the selection committee will endeavor to select, where possible, local artists from White Rock, South Surrey, or Semiahmoo First Nations.**

Note: Current wording in the Public Art Advisory Committee Terms of Reference is as follows:

When calling for artists, the selection committee must endeavor to select only local artists from White Rock, South Surrey, or Semiahmoo First Nation.

2. Community Public Art Program

The goal of a Community Public Art Program is to create artwork that is accessible to the public, in a public space. By virtue of its placement, content and public engagement, public art shapes the environment. Successful community art can help communities change the local environment and develop a sense of pride and ownership over their public spaces.

A Community Public Art Policy will:

- a) Create a livable community by linking arts and everyday life.
- b) Encourage community participation in ways that respect the diversity and interests of our neighbourhoods.
- c) Strengthen community identity, spirit and collective cultural experiences.
- d) Increase public understanding of the role of art and artists in the community.

Community public art focuses on the vision and belief systems of the community. A community based design process helps people articulate their concerns and goals in terms of public art creating opportunities for community participation. In this way, people's knowledge and experience become part of the design.

3. Private Sector Public Art Program

The private sector public art program is designed to encourage developers to commission site-specific art works that are integrated into the public spaces adjacent to or part of the development project. Developers see the benefits

inherent to public art as a means to enhance their project by adding interest and character to their developments. Public art can improve the public realm, whether publicly or privately owned, and create a destination for residents and visitors alike, thereby contributing to the local economy.

City staff, when reviewing new developments, will encourage developers to incorporate public art in their projects. Proposals received or referred to the Public Art Advisory Committee (PAAC) from private individuals or organizations will be reviewed and assessed by the PAAC. The review will consider artistic merit, ongoing maintenance demands and the process for implementing the project.

A Private Development Public Art Policy will:

- a) Encourage the private sector to seek out the PAAC to review and assess public art projects
- b) Reflect a range of artistic expression, demonstrate excellence, quality and innovation
- c) Create landmark features on new developments and revitalize the urban landscape

Developers may wish to hire an independent consultant to provide advice on public art opportunities, potential locations for public art and artists' resources. Creation, installation, maintenance and repair of artwork on private property is the responsibility of the property owner, unless otherwise established by agreement with the City.

2. **DEFINITION OF PUBLIC ART**

The definition of public art, for the purposes of this policy, is defined broadly to include all art forms, permanent or temporary, which are located in, part of, or associated with a public space, environment or facility that is highly accessible to members of the public. Without limiting the definition of public art, the following spheres of public art are included:

- Permanent artworks created for (often specific) public places.
- The collaboration of artists, architects, and landscape or urban designers to create unique physical environments or features, which integrate art into the urban fabric.
- Artworks produced by or through the involvement of the community (where they result in art in public spaces).
- Temporary art exhibits/performances/exhibitions/events/installations in public spaces.

Examples of public art could include sculptures, murals, functional art (e.g. designed public seating, paving, manhole covers, forms of landscaping, sound and light works, water or glass features).

This policy will apply to public art that is created, facilitated, owned or maintained by the City of White Rock.

3. **COUNCIL’S STRATEGIC DIRECTION AND MONITORING**

The Public Art Policy will be in keeping with the strategic documents and direction set by Council.

The City of White Rock Annual Report will reference public art. Council will then be able to monitor the performance of the Public Art Policy with consideration given to the following measurable outcomes:

- The number of artworks in the public domain.
- Level of compliance with the Public Art Policy.
- The amount of funding devoted to public art in White Rock.
- The number of new types of artworks installed in public places each year
- The diversity of cultures and types of artworks represented by the artists that either gift works or are commissioned to produce public art that will be owned by the City.

4. **FUNDING**

During the annual budgeting process consideration will be given to fund a *Public Art Reserve*. The Public Art Reserve will hold funds until such a time as their use is directed by Council based on recommendations from the Public Art Advisory Committee.

Public Art Reserve monies may be applied to:

- Selected capital projects such as new building construction, major additions to existing buildings, or major park development projects.
- Small-scale community public art projects proposed jointly by community non-profit organization(s) and artist(s).
- Installations for gifted works.
- Consultant fees for commissioning works for the Public Art Program.

1. **Community Public Art Funding**

\$50,000 will be considered annually for Community Public Art projects. The funds will be used for the following:

- a) Community Art. Applicable projects are ones initiated by the community such as “Youth at Risk” art programs.
- b) Public art around the City. Applicable projects can include banner programs, manhole and mural programs.

c) Managing, maintenance and installation of Community Public Art.

In the City's annual operating budget an appropriate amount will be set aside for the insurance and maintenance of public art works.

2. City Public Art Funding

- a) In the annual capital planning process 1.25 percent of large capital cost projects will be considered for city public art projects. Applicable projects include new building construction, major additions to existing buildings, and major park development projects.
- b) City Public Art funding does not apply to costs normally associated with capital projects such as design and engineering, insurance, fees and permits, building demolition, relocation of tenants, contingency funds, land acquisition, environmental testing or other engineering project costs.
- c) Public Art projects cannot be funded retroactively, and cannot receive funds from other city cultural grant programs.

As matching funds are often available, Council will work with various organizations, the business community and other levels of government to fund and promote community public art.

5. Public Art Advisory Committee (PAAC)

Council will set up a Public Art Advisory Committee (PAAC) committee. The committee's duties will be included in the Term of Reference (Council Policy 147).

These duties will include:

- Overseeing the direction of the Public Art policies and making recommendations to Council for the allocation of funds.
- Representing the needs and interests of the community in the public art process.
- Ensuring that Artists are selected through an informed, open and fair public art competition process with consideration being given to local, regional and national artists.
- Advising Council on the implementation of the Public Art policies, including selection processes, acceptance of gifts, donations, bequests, loans, and de-accessions.

The committee will be composed of individuals who have expertise in fields related to public art. In order to facilitate the work of the PAAC, and to ensure the on-going development and administration of a public art program, a City staff member will be appointed as the staff liaison.

The public art program will be set up so that each project is reviewed by all appropriate staff.

PAAC will be kept apprised of any public art submissions through the Private Sector policy.

General awareness of all public art initiatives will be shared throughout the City and all City departments will be encouraged to consider opportunities for the appropriate integration of public art.

6. PUBLIC ART SELECTION PANEL (PASP)

The Public Art Advisory Committee will convene a selection panel for each significant Public Art Project (for the Selection Process see Appendix 2).

1. Selection Panel Terms of Reference

The Terms of Reference for the selection panel will be developed by the Manager, Cultural Development on a per project basis and in conjunction with the PAAC. On larger projects it may be desirable to give selection panels' broad terms of reference and responsibility for determining sites, budgets, the nature of the artist participation and recommended selection processes.

A selection panel usually consists of three to seven voting members as well as non-voting advisors as are needed to supply technical information or community advice. The panel process should also allow for neighbourhood input or representation and panellists should reflect community diversity.

A typical panel might consist of the following.

- a) Developer representative (if required).
- b) One member from the design community (Architect, Landscape Architect).
- c) Three representatives from the art and design community (preferably two artists).
- d) One member from the Public Art Advisory Committee.
- e) One member from the community at large.
- f) Non-voting advisors including city staff, project staff, technical staff.

Smaller projects may suffice with only three panelists; one from the Art Community, one architect or landscape architect and a member from the community at large.

7. ACQUISITIONING, COMMISSIONING OR ACCEPTING GIFTS OF PUBLIC ART

The City of White Rock will acquire pieces of art through the Public Art Program. It is important to ensure the quality and integrity of artwork commissioned and its relevance to the community and site. Before any work of art is accepted recognition must be given to the following:

1. Meeting the Objectives of the Public Art Policy

Primary consideration should be given to the objectives of public accessibility quality and diversity. Diversity should be taken to mean diversity of culture and of type of art (for example non-functional versus functional art; 'fine art' versus 'community art'; temporary versus permanent).

2. Cost of Maintenance and Installation

The costs of maintenance over a ten year period should be estimated and assessed, along with an indication of the expected life of the artwork. Maintenance and installations costs should be reasonable in relation to the value of the artwork, and affordable within operational maintenance and installation budgets.

3. Safety

Public art is, more often than not, physically accessible to the public. Art works therefore need to be both physically robust and safe to members of the public. Issues of safety are of primary concern.

4. Artistic Merit and Quality of the Work

Artworks will and should be the subject of debate as to their artistic merits. Bearing in mind the primary objective of gaining quality and diverse public art, regard should be given to:

- a) The anticipated public response and interaction.
- b) Accessibility to the public.
- c) The degree to which the artwork reflects White Rock's character and/or contemporary culture.
- d) Expert judgment as to the merits of the art work.
- e) The degree to which its artistic merits will be endured in relation to the costs associated with its adoption.

5. Gifts, Donations and Bequests

The PAAC will consider acceptance of gifts, donations and bequests of artwork (in the form of existing works or offers to commission new work) according to the following criteria:

- a) Ability to integrate work in the City's existing Public Art Collection.
- b) Quality and condition of the work, based upon professional assessment and a detailed written proposal that is accompanied with drawings, maquette (model) and/or photographs.
- c) Fairness of the process whereby the work and artist were selected.
- d) Suitability of the theme of the artwork to a public venue.

- e) Appropriateness to site, if applicable.
- f) Susceptibility of the work to degradation, wear or vandalism and any potential of endangering public safety.
- g) Suitability of the work to technical installation requirements of public spaces.
- h) Suitability of the work to variable environmental conditions.
- i) Financial implications of acceptance based on installation, maintenance, insurance, and restorative/repair cost estimates.
- j) Provision by the donor for ongoing maintenance and, where relevant, the cost of future relocation or removal.
- k) Authenticity: legal title, copyright, moral right.

For gifts, donations and bequests the donor must outline the offer in writing to staff. The donor then may appear as a delegation to present the work or staff will present it. The PAAC will make the recommendation to Council to accept or decline the gifted, donated or bequested artwork.

8. MANAGEMENT OF THE PUBLIC ART COLLECTION

1. Collection Management

- a) The management, maintenance and insurance of the Public Art Collection is the responsibility of the City. The costs of maintenance and insurance of the public art and privately owned art in publicly accessible locations will be incorporated into purchase/donation/gift agreements or any other agreements deemed appropriate to ensure the ongoing term maintenance of artwork in public places.
- b) The Public Art Collection will be managed according to appropriate professional inventory and documentation practices.

2. Risk Management and Liability

- a) As the creation of art is atypical and is not governed by construction standards, there is need to apply some means to ensure that public safety is not put at risk through the installation of public art projects.
- b) The City will review projects to identify and reasonably address potential hazards. Artists commissioned will similarly be required to give due care to public safety in the design, fabrication and installation of public art pieces.

3. Inventory

An inventory of public artworks owned by the City will be created and maintained. Documentation procedures will conform to standard museum practice citing:

- a) Title of artwork.
- b) Date work was completed.
- c) Provenance.
- d) Purchase/commission price and insurance value upon acquisition.
- e) Photographic and written description detailing materials, construction, dimensions, location, site conditions and context of the work.
- f) Artist's statement of the work and biographical information.
- g) Published material about the artwork.

4. Removal or Relocating Public Artworks

Occasionally decisions will need to be made about either removing or relocating public artworks from the City's collection for a range of reasons including artistic relevance, public safety, changes to the design and use of the public space occupied by the artwork, and the possibility that a new and better site has become available for an artwork.

Reassessment of a work's suitability as a continuing part of the community public art collection should take into account:

- a) The primary objective of the policy is to increase the amount, quality and diversity of public art in White Rock.
- b) Where possible, decisions should involve discussions with the artist(s) and other relevant people or organizations involved in its establishment.
- c) That the Community Public Art Policy emphasizes raising awareness of public art and promoting opportunities for the public to access public art and, as such, the storing of public artworks is generally to be discouraged.
- d) Whether an artwork continues to be relevant to its location.
- e) Whether the work forms part of a collection.
- f) The popularity of the artwork with the public.
- g) If an artwork needs to be moved, consideration should be given to whether another site can be located.

Decisions on deaccession of public artwork will be made by the Public Art Advisory Committee. The determination would be based on one or more of the following reasons:

- a) The ongoing good condition or security of the artwork cannot be reasonably guaranteed.
- b) The artwork requires excessive maintenance or has faults in design or workmanship and repair or remedy is either impractical or infeasible.
- c) The artwork has been damaged and repair is either impractical or infeasible.
- d) The artwork endangers public safety.
- e) The artwork is not, or is only rarely on display owing to the lack of a suitable venue.
- f) Significant alterations in the use, character or design of the site have occurred which affect the integrity of the work and its relation to its environment.
- g) Significant adverse public reaction has continued over an extended period of time.
- h) The quality or authenticity of the artwork is debatable and subsequently justified.
- i) PAAC deems that the same artist should replace the artwork with a more appropriate work.
- j) The artwork has been assessed to be of inferior quality compared to other works in the collection, or has been determined to be incompatible with the rest of the collection.
- k) Removal is requested by the artist.
- l) The site is no longer accessible to the public or the physical setting is to be re-developed.

Options for deaccession of public art works include:

- a) Re-location to another appropriate site.
- b) Selling or gifting the artwork back to the artist.
- c) Donating to a community group or facility or organization that operates for public benefit.
- d) Open sale or auction.
- e) Other removal as appropriate.

Decisions on the above options will need to be made on a case by case basis, based on criteria which include:

- a) Resale value.
- b) Sensibilities around how the City came to own the artwork.
- c) Condition of the work.

5. **Managing Controversy**

The Public Art Advisory Committee should:

- a) Ensure the provision of opportunities for direct and informed public involvement in the direction and selection of public artwork.
- b) The Community Public Art Policy must provide a responsible, public selection process which in turn ensures that secured artwork is supported by the community.
- c) If reasonable efforts by the Public Art Advisory Committee to resolve the concern have failed, PAAC will appoint an impartial third party of art and design professionals to resolve the conflict. The recommendation of the third party member will require the approval of Council.

9. **RATIONALE**

The following is the rationale for both the City and Community Public Art programs:

1. **City Public Art Program**

A consistent and key principle underlying the successful development and implementation of a City Public Art Program is the demonstration of leadership and commitment by the City in initiating and facilitating the creation of public art as an integral component of its city capital projects.

2. **Community Public Art Program**

The goal of a Community Public Art Program is to create artwork that is accessible to the public, in a public space. By virtue of its placement, content and public engagement, public art shapes the environment. Successful community art can help communities change the local environment and develop a sense of pride and ownership over their public spaces.

3. **Private Sector Public Art Program**

The objective of a Private Sector Public Art Program is to encourage developers to contact the Public Art Advisory Committee and submit a detailed public art plan. A strong Private Sector Public Art Program contributes to the character of the City and demonstrates the significance of arts in everyday life.

10. **COMMUNITY CONSULTATION PROCESS: PUBLIC ART ON CITY OWNED RETAINING WALLS**

The addition of art in public spaces creates a more aesthetically pleasing environment for residents, workers and visitors. The following is a community consultation process to be followed when the City of White Rock initiates a public art project on retaining walls that are adjacent to a residents' home.

1. Pick a potential site. Criteria to include:
 - City owned property
 - Public access to the site
 - Visible to the public
 - The capacity of the site to sustain art
2. The City of White Rock will hold an invitational focus group meeting with the purpose to determine the themes and characteristics for the site. Key stakeholders specific to the site include city staff and adjacent property owners.
3. The City of White Rock will choose a budget that includes artist fees, material costs, installation costs and maintenance.
4. The City of White Rock will initiate a call for artists from information collected at the focus group meeting.
5. The City of White Rock will select a panel of jurors in accordance with the Selection Panel Terms of Reference of the Public Art Policy. The selection panel will take into consideration if the artist has reflected the themes presented in the artist call and stayed within budget.

For City owned retaining walls, the panel of jurors should include:

- Adjacent property owners
 - Three representatives from the art and design community
 - Manager of Cultural Development
6. The City of White Rock will award the project to the artist who achieves the highest combined score.
 7. The City of White Rock will send a letter to residents within a minimum of a two block radius with a draft of the proposed art and allow at least two weeks for feedback.
 8. The City of White Rock will finalize design, timeline and sign a contract with the artist.

PUBLIC ART SELECTION PROCESS

1. Preparing for Artist Selection

- a) Identify potential project and location for public art.
- b) Determine budget for the project.
- c) Determine method of selection (open competition, limited competition, and direct selection).
- d) Determine if the call will be local, regional, national or international and whenever possible consideration should be for local, regional and national.
- e) Write the Call for Artists.
- f) Post the Call.
- g) Identify Public Art Selection Panel members. A Public Art Selection Panel (PASP) will be convened for each major public art project. The purpose of the PASP is to select the highest qualified artist(s) to complete the project.
- h) Selection panel reviews submissions and short-lists artists.
- i) Short-listed artists commissioned to either prepare a drawing, maquette and/or site plan.
- j) Selection panel meets to review short-listed proposals. One finalist is selected to initiate the artwork. Note: Some finalists are composed of more than one artist.

2. Selection and Commissioning of Artist

- a) Initiation of the contract preparations.
- b) Artist may be required to revise plan to address issues identified by PASP, developer and/or staff.
- c) Revised plans, construction drawings/model prepared by the artist.

3. Selection Process for Commissioning Artists

There are three accepted methods of selecting a public artist:

- a) **Open Competition:** Artists may submit requested materials from a public call for qualifications. Mailing lists should be advertised or by a database of names. Consideration should be given to local, regional and national artists.
- b) **Limited Competition:** A limited number of artists may be requested to submit qualifications for a specific project. This competition is usually employed when the project specifies a particular art form, or there are unusual time constraints. Names of artists should be submitted by the Public Art Advisory Committee or the Public Art Selection Panel.
- c) **Invitation or Direct Selection:** One artist may be invited to submit qualifications. Upon acceptance of the artist's qualifications, the artist is commissioned for the project. This method is rarely employed due to possible perceptions of favoritism and other political difficulties.

Artists are selected on the basis of their qualifications as demonstrated by past work, ability to handle a budget, creativity appropriateness of the proposal to the project.

Short-listed artists will be requested to prepare a proposal for the project.

Where possible, the City will encourage the developer (if involved) to engage in a collaborative process for City Public Art whereby artists become equal members of a design team under the direction of the PAAC. The benefits of collaboration are many: better ideas, wider range of approaches, higher levels of energy and a broader spectrum of skills. The artists' involvement will encourage the design process to integrate art and architecture. This is especially important in instances where concerns regarding safety, operations, maintenance, vandalism, and the interaction of people often eliminate the possibility of including applied or discrete art pieces.

Working with architects, landscape architects and engineers gives the artist the opportunity to create projects, which will attract people by adding an aesthetic overview. Integral to the success of a collaborative process, it is important that all members of a team understand the following points:

- Adding the artist to the design team early in the process creates the opportunity to leverage the cost of the artwork.
- Art is an important aspect of the project.
- Artists must be recognized as equal member of the design team.

4. Artist Application Materials

Materials to be submitted by the artists should include:

1. A letter of interest, no more than one page in length, that explains the artist's particular interest in the project, applicable experience that has prepared the artist for this project, and availability to work within the established timeline. Issues to be addressed should include design team participation and experience with collaborative design.
2. A current resume.
3. In hard copy: One (1) copy of a CD or USB Flash Drive containing a maximum of 20 digital images of the artist's work in a JPEG format with 300 DPI. All images must clearly identify the title of the artwork, location, media, size and other relevant information.
4. A numbered image list with the artist's name and a brief description of each image stating the title, date, medium, size, location and, if a commissioned project, the commission contract cost.
5. References required: Each artist applying should list at least one design professional (architect, landscape architect, engineer, graphic designer, etc.), and two artists who have an intimate knowledge of the artist's work and working methods. Include complete addresses and telephone numbers. For artists with no prior involvement with public art projects, please list at least two art professionals and one artist as references.
6. A self-addressed, stamped envelope for return of USB Flash Drive.

5. Selection Panel Guidelines

The Manager, Cultural Development will develop a Public Art Selection Panel in association with City staff and PAAC.

A new Public Art Selection Panel is convened for each project. The purpose of the selection panel is to select the highest qualified artist(s) to complete the project.

Depending on the size of the project, most panels consist of the following appointments:

- Developer representative (if required).
- One member from the design community (Architect, Landscape Architect).
- Three representatives from the art and design community (preferably two artists).
- One Member from the Public Art Advisory Committee.
- One member from the community at large.
- Non voting liaisons including city staff, project staff, technical staff.

Smaller projects may suffice with only three panelists; one from the art community, one architect or landscape architect and a member from the community at large.

1. Selection Panel Goals

The goals of the artist selection process are threefold:

- a) To implement the agreed upon goals of the project through an appropriate art selection.
- b) To seek quality and integrity in the artwork.
- c) To choose an artist(s) who will best respond to the distinctive characteristics of the site.

2. Selection Panel Process

Panelists must be well informed about the project for which they are selecting an artist. It is important that an orientation meeting be provided for the panel members. At this meeting they will be provided with written materials and drawings on the specific area in which the selected artist will be working. There should be an opportunity to visit the site and to have issues and questions answered by staff and representatives of the City.

Members of the Public Art Selection Panel should have one vote, and no member should have the right of veto. The selection of an artist should be based on a consensus vote by the panel. If a consensus cannot be reached, then the majority vote carries the decision. The committee should have the option to make no selection if there is not a submission that warrants consideration.

In some instances, groups that might have a special interest in the project will be invited to appoint non-voting advisors to the jury. The comments of these advisors would be solicited by the panel prior to making a final decision.

Costs incurred by the panelists such as parking and childcare will be paid. Meals will be provided for the panelists.

3. Selection Criteria

The Selection Panel should select finalists to be interviewed based on the quality of their application. The finalists should be interviewed by the jury using the following criteria:

- a) Artist's work habits and history:
 - Resume.
 - Ability to think conceptually.
 - Problem solving abilities.
 - Ability to meet deadlines.
 - Experience with budgeting and staying within a budget.
 - Familiarity working with and reading technical drawings.
- b) Artist's collaborative abilities:
 - Ability to work as a member of a team.
 - Communication skills.
 - Ability to carry out principled negotiations.
 - Flexibility.
- c) Artist's awareness of the project:
 - Perception of project.
 - Awareness of community attitudes and concerns.
 - Familiarity with project design.
 - Ability to understand and accept the timeline.

Project Eligibility

Projects will be selected by a Selection Panel according to the following criteria:

- a) Artistic merit and innovation.
- b) Significance of the project to the specific site and surrounding neighborhoods.
- c) High degree of public use or public realm impact.
- d) Demonstrated support and involvement of the community.
- e) Technical feasibility and quality of production.
- f) Art work must be safe, durable and vandal resistant.
- g) Probability of successful completion within stipulated timelines and budget.

Other criteria specific to the project might be included relating to issues of safety, operational requirements, maintenance.

Ineligible Projects

- a) Heritage buildings.
- b) Privately owned works (except where they are located in public places).
- c) Community arts programs (except where they result in art installations in public places).
- d) Contemporary advertising/billboards.
- e) Special Events / Festivals.

- f) Directional elements such as super graphics, signage or colour coding except where these elements are integral parts of the original work of art or public art project.
- g) Art objects which are mass-produced of standard design such as playground equipment, fountains, or statuary objects.
- h) Reproductions, by mechanical or other means, of original works or art, except in cases of film, video, photography, printmaking or other media arts.
- i) Decorative, ornamental, architectural or functional elements, except where they are an integral part of the original work of art, or are the result of collaboration among the design professionals including at least one artist.
- j) Landscape architecture and landscape gardening except where these elements are an integral part of the original work of art, or are the result of collaboration among design professionals including at least one artist.

PUBLIC ART DEFINITIONS

Artist

A person generally recognized by his/her peers, critics and other art professionals as committed to producing works of art on a regular basis.

Artwork

A tangible creation by an artist.

City Public Art Program

A consistent and key principle underlying the successful development and implementation of a City Public Art Program is the demonstration of leadership and commitment by the City in initiating and facilitating the creation of public art as an integral component of its city capital projects.

Commissioned Work

Usually consists of discrete pieces of artwork that has been commissioned by Open, Limited or invitational competition. It may be public art that is not integrated with the site either in a physical or conceptual manner. Usually, this type of public artwork only relates to the site from a location and scale pin of view and is created off site. However, some commissioned pieces do relate to the site both in terms of location, geography, and the site. These may also be termed as discrete pieces, but the artist has addressed the physical components of the site and the surrounding area.

Community Public Art

Community Public Art Programs provide funding for small-scale public art projects proposed jointly by community groups or organizations in collaboration with artists.

Public art that is created as a result of a collaborative process between a professional, practicing artist(s) and a self-defined community. It is a collective method of art making, engaging artists and communities through collaborative, creative expression.

Community Art projects may result in either temporary or permanent works of art. The funds for Community Public Art Program are accessible to community individuals, as well as profit and not for profit groups through the Community Public Art Program Grant Application Form.

Competitions

There are three basic types of competition: “open” competitions are open to a wide range of entrants who may submit entries and “limited” competitions, which are open to only a few invited entrants. As well, “invitational competition” occurs when sponsors invite one specific artist to submit proposals for jury.

Contract or Agreement

A binding, legal document by which parties agree to perform certain services.

De-accession

To sell (a work of art) from a museum's or gallery's collections, especially with a view to acquiring funds for the purchase of other works.

Design Collaboration

Projects created through the co-equal cooperative design efforts of design professionals, such as artists, architects and landscape architects.

Design Professionals

Individuals professionally trained in design, such as architecture, landscape architecture art, graphics, urban design, and planning; also graphic, industrial, interior, and clothing design.

Discrete

Public art that is not integrated with the site either in a physical or conceptual manner. Usually this type of public artwork only relates to the site from a location and scale point of view and is created off site and is often moved into the place.

Integrated Public Art

Public Art that becomes part of the urban infrastructure of a City or a community. It reflects the social, cultural, architectural and historic nuances of the place there by creating a sense of place.

Leverage

Integrated public art is often added to building or landscape parts such as pillars, walkways, seating, flooring, etc. The original cost for these items are added to the public art budget, thereby increasing or leveraging the cost of the artwork.

Maquette

Refers to the drawing or model of the proposed artwork.

Percent for Art Programs

A public art program funded by a percentage (usually 1 to 2%) of gross construction budgets, for the commission, design; purchase and installation of artwork in the public realm.

Permanent Installation

Artwork or an art place which has a permanent site, as opposed to a temporary site.

Program Costs

The amount that is taken off the top of the total art allocation, in order to administer the project. This amount is used for, but not limited to, the following: advertising, printing of competition briefs, jury fees, artist's maquette fees, plaque, lighting of work, invitations for official openings, photo documentation of the finished work, contingencies etc. Management costs vary according to type of competition and project.

Provenance

Place or source of origin.

Public Art

Publicly accessible original art that enriches the City as it evokes meaning in the public realm. It can be of a variety of forms and takes into consideration the site, its location and context, and the audience. Public art may possess functional as well as aesthetic qualities. Public art can be related to the site in three different ways: integrated, semi-integrated and discrete. (See definition of integrated).

Public Art Consultant (PAC)

An advisor to the project on art sitting, selection, and artist issues. Consultants should have a broad knowledge of current art-making practices and of artists able to work in public and development contexts.

Public Artwork Collection

All works of art owned by the City that are site specific, part of a portable collection or documentation of works of specific duration.

Public Art Reserve Fund

A City-maintained account of funds generated by the public art requirement which is dedicated to the cost of public art planning, administration, documentation, education, and the creation of public art. This fund is made up of a variety of sources including cash in lieu of the public art requirement, donations, etc.

Semi-Integrated

Public art that derives to some degree, its conceptual inspiration, from some aspect of the site and displays a heightened degree of physical and conceptual integration. These works may exist in a number of locations providing that all possess the same requisite physical and conceptual conditions, i.e. a piece which must be located in a windy open field condition could be located in any windy open field anywhere (see Integrated and Discrete).

Site Specific Work

An artwork that relates in content, form and/or image to its surroundings.

Statuary

A group or collection of statues.

Rationale:

This policy has been established to set out the purpose, principles, goals, considerations and processes in regard to public art.

THE CORPORATION OF THE
CITY OF WHITE ROCK
BYLAW NO. 2324

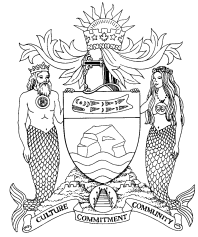

A revenue anticipation bylaw providing for the borrowing of sums of money as may be requisite to meet the current lawful expenditures of the City.

WHEREAS the Council of the City is empowered by Section 177 of the "Community Charter", without the assent of the electors or the approval of the Inspector of Municipalities, by Bylaw to provide for the borrowing of such sums of money as may be required to meet the current lawful expenditures for the year 2020 of the City, such borrowing not to exceed in the aggregate the sum of seventy-five per cent of all taxes levied for all purposes in the preceding year.

AND WHEREAS the aggregate that the Council may presently borrow, calculated in accordance with the above, is \$35,400,000.

AND WHEREAS to meet the current lawful expenditures for the year 2020 of the City, it is requisite that the Council borrow up to \$5,000,000.

NOW THEREFORE, the Council of the Corporation of the City of White Rock, hereby enacts as follows:

1. It shall be lawful for the said City Council to borrow upon the credit of The Corporation the sum of Five Million Dollars (\$5,000,000) in such amounts and at such times as the same may be required, and to pay interest thereon.
2. All the monies so borrowed and interest payable thereon shall be repaid on or before the 31st day of December, 2020.
3. There is hereby set aside as security for the liability hereby authorized to be incurred \$5,000,000 being that part of the taxes for the current year, 2020, deemed by the City Council to be so set aside.
4. This Bylaw may be cited as the "*White Rock Revenue Anticipation Borrowing Bylaw, 2020, No. 2324*".

RECEIVED FIRST READING on the	day of	2020
RECEIVED SECOND READING on the	day of	2020
RECEIVED THIRD READING on the	day of	2020
ADOPTED on the	day of	2020

MAYOR

CITY CLERK

**The Corporation of the
CITY OF WHITE ROCK
BYLAW 2320**



A Bylaw to amend the
"White Rock Zoning Bylaw, 2012, No. 2000" as amended

The CITY COUNCIL of the Corporation of the City of White Rock, in open meeting assembled, ENACTS as follows:

1. That Section 4.1 "Uses Permitted/Not Permitted – General" of the "White Rock Zoning Bylaw, 2012, No. 2000" as amended, be amended as follows:
 - (1) By deleting the existing section 4.1.5 in its entirety and replacing it with the following new section 4.1.5:
 - 4.1.5 a) The commercial cultivation, growth, production, storage, barter or sale of cannabis, or any products containing or derived from cannabis, is not permitted in any zone except as otherwise provided in this bylaw. This includes licensed producers regulated under applicable provincial or federal legislation, and *cannabis stores*.
 - b) The retail sale of cannabis accessories, as defined by the federal *Cannabis Act*, is permitted within a *cannabis store* but is not permitted within 500 metres of a zone that permits a *cannabis store* or within 500 metres of a property where a *cannabis store* is authorized by a Temporary Use Permit.
2. That Section 7.16 of Schedule "B" – Comprehensive Development Zones' of the "White Rock Zoning Bylaw, 2012, No. 2000" as amended, be amended as follows:
 - (1) By adding a new permitted use in subsection 7.16.1 in the correct alphabetical order, as follows:
 - (g) a *cannabis store*
 - (2) By adding a new location of permitted uses in subsection 7.16.2(a), as follows:
 - (iv) a *cannabis store* must only be located in the 1st floor of the building identified as Building 3 on the plans, and the commercial retail space containing the *cannabis store* shall be not be located within 8 metres of Johnston Road

3. This Bylaw may be cited for all purposes as the "White Rock Zoning Bylaw, 2012, No. 2000, Amendment (CD-16 – Cannabis Store) Bylaw, 2019, No. 2320".

PUBLIC INFORMATION MEETING on the	18 th	day of	September, 2019
RECEIVED FIRST READING on the		day of	
RECEIVED SECOND READING on the		day of	
PUBLIC HEARING held on the		day of	
RECEIVED THIRD READING on the		day of	
RECONSIDERED AND FINALLY ADOPTED on the		day of	

Mayor

Director of Corporate Administration

**The Corporation of the
CITY OF WHITE ROCK
BYLAW 2323**



A Bylaw to amend the
"White Rock Zoning Bylaw, 2012, No. 2000" as amended

The CITY COUNCIL of the Corporation of the City of White Rock, in open meeting assembled, ENACTS as follows:

1. That Section 4.1 "Uses Permitted/Not Permitted – General" of the "White Rock Zoning Bylaw, 2012, No. 2000" as amended, be amended as follows:
 - (1) By deleting the existing section 4.1.3(b)(ii) in its entirety and replacing it with the following new section 4.1.3(b)(ii):
 - (ii) there shall be no more than three lots containing a *cannabis store* use in the area bounded by North Bluff Road, George Street, Thrift Avenue, and Martin Street;
2. This Bylaw may be cited for all purposes as the "White Rock Zoning Bylaw, 2012, No. 2000, Amendment (Cannabis Store Separations) Bylaw, 2020, No. 2323".

RECEIVED FIRST READING on the	day of	January, 2020
RECEIVED SECOND READING on the	day of	January, 2020
PUBLIC HEARING held on the	day of	
RECEIVED THIRD READING on the	day of	
RECONSIDERED AND FINALLY ADOPTED on the	day of	

Mayor

Director of Corporate Administration

**THE CORPORATION OF THE
CITY OF WHITE ROCK**



DEVELOPMENT VARIANCE PERMIT NO. 426

1. Development Variance Permit No. 426 is issued to **Wong Yuet Wah Chau and Rosa Kwok Lai Chow** as the owner and shall apply only to ALL AND SINGULAR that certain parcel or tract of land and premises situate, lying and being in the City of White Rock, in the Province of British Columbia, and more particularly known and described as:

Legal Description:

West Half Lot 2 Except: The West 7 Feet; Section 11 Township 1 New Westminster
District Plan 8096
(Civic: 1478 Johnston Road)

PID: 011-426-381

As indicated on Schedule A – Subject Property Location Map

2. Development Variance Permit No. 426 is issued pursuant to the authority of Section 498 of the *Local Government Act*, R.S.B.C. 2015, Chapter 1 as amended, and in conformity with the procedures prescribed by "White Rock Planning Procedures Bylaw, 2017, No. 2234" as amended.
3. The provisions of "White Rock Zoning Bylaw, 2012, No. 2000 as amended, is varied as follows:

Section 4.1.3(b)(i) is varied to reduce the required setback from the premises containing the *cannabis store* use to existing *child care centre* from 100 metres to 80 metres.
4. Said lands shall be developed strictly in accordance with the terms and conditions and provisions of this Development Variance Permit.

Terms and Conditions:

5. The variance is for the use of commercial premises within the existing building as a *cannabis store*.
6. This permit expires in the event that the existing building is demolished or if the licence issued in accordance with the *Cannabis Control and Licensing Act*, as amended, is cancelled. Any new buildings or structures will be required to meet the Zoning Bylaw requirements in place at the time of the building permit application.
7. Where the holder of this Development Variance Permit does not receive final approval of a building permit for the tenant improvements for the proposed *cannabis store* use within

two (2) years after the date this Permit was issued, the Permit shall lapse, unless the Council, prior to the date the Permit is scheduled to lapse, has authorized the extension of the Permit.

8. This Development Variance Permit does not constitute a building permit.

Authorizing Resolution passed by the City Council on the _____ day of _____, 2020.

This Development Variance Permit has been executed at the City of White Rock, British Columbia, the _____ day of _____, 2020.

The Corporate Seal of THE CORPORATION
OF THE CITY OF WHITE ROCK was hereunto
affixed in the presence of:

Mayor – Darryl Walker
Authorized Signatory

Director of Corporate Administration – Tracey Arthur
Authorized Signatory

Schedule A – Subject Property Location Map

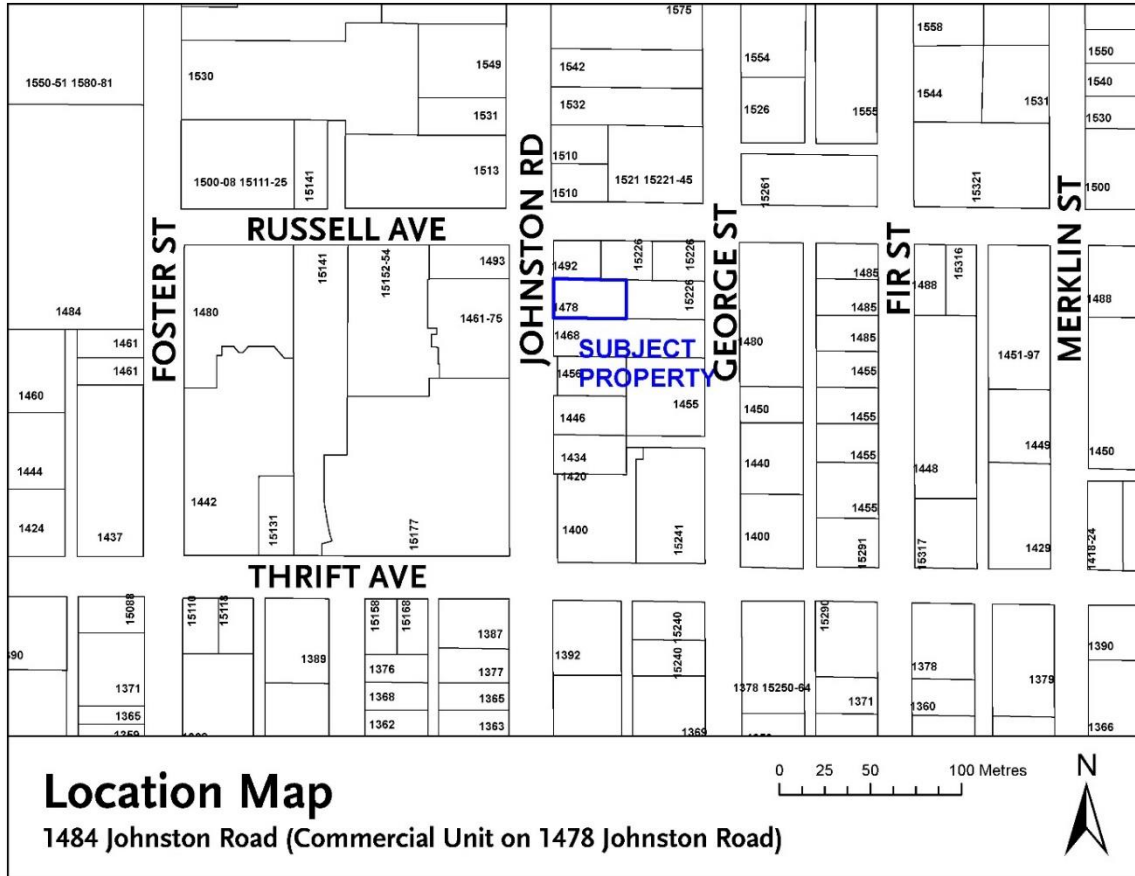

THE CORPORATION OF THE
CITY OF WHITE ROCK



TEMPORARY USE PERMIT NO. 19-012

1. This Temporary Use Permit No. 19-012 is issued to Wong Yuet Wah Chau and Rosa Kwok Lai Chow as the owner (hereinafter called the "Permittee") and shall apply only to ALL AND SINGULAR those certain parcels or tracts of land and premises situate, lying and being in the City of White Rock, in the Province of British Columbia, and more particularly known and described as:

Legal Description:

West Half Lot 2 Except: The West 7 Feet; Section 11 Township 1 New Westminster District Plan 8096
PID: 011-426-381
(Civic: 1478 Johnston Road)

As indicated on Schedule A

(hereinafter referred to as "the Lands").

2. This Temporary Use Permit No. 19-012 is issued pursuant to the authority of Sections 492 and 493 of the *Local Government Act, R.S.B.C. 2015, Chapter 1* as amended, the "White Rock Zoning Bylaw, 2012, No. 2000" as amended; and in conformity with the procedure prescribed by the "City of White Rock Planning Procedures Bylaw, 2017, No. 2234" as amended.
3. Except as otherwise authorized by this permit, the terms, conditions and guidelines as set out in the "White Rock Zoning Bylaw, 2012, No. 2000" as amended shall apply to the Lands covered by this Temporary Use Permit:

a) Permitted Temporary Uses

- (i) *A cannabis store*

4. Terms and Conditions:

- a) Except as otherwise specified in this permit, all siting, construction, and use shall be in accordance with the provisions of the "White Rock Zoning Bylaw, 2012, No. 2000" as amended;
- b) The permittee must obtain a building permit and comply with the requirements of the BC Building Code for the construction of the interior tenant improvements;
- c) The premises containing the *cannabis store* use must be no larger than 160 square metres;
- d) The permittee must obtain a sign permit, and not have any signage promoting the business on the east side of the building;

- e) The driveway access must have a speed hump, stop sign, and pedestrian crossing warning sign installed on the property, in accordance with recommendations of the report dated June 27, 2019 from Aaron Chang, P.Eng, Creative Traffic Solutions, titled “1484 Johnston Road Traffic Engineering Services White Rock, BC, attached hereto as Schedule B;”
 - f) The driveway access must be delineated on the Johnston Road portion of the building to the satisfaction of the Director of Engineering and Municipal Services, in general accordance with recommendations of the report dated June 27, 2019 from Aaron Chang, P.Eng, Creative Traffic Solutions, titled “1484 Johnston Road Traffic Engineering Services White Rock, BC, attached hereto as Schedule B;”
 - g) The permittee must provide a minimum of nine on-site parking spaces for the *cannabis store* use;
 - h) The permittee must maintain a minimum of five off-site parking spaces for the employees of the *cannabis store*;
 - i) The *cannabis store* shall not be open to customers prior to 10:00 AM on any day and shall be closed no later than 11:00 PM from Monday to Saturday and 8:00 PM on Sunday;
 - j) The *cannabis store* shall not sell any goods or things until it has obtained a valid licence issued in accordance with the *Cannabis Control and Licensing Act*, as amended, and a valid business licence;
 - k) This temporary use permit is automatically revoked if the licence issued in accordance with the *Cannabis Control and Licensing Act*, as amended, is suspended or cancelled;
 - l) This temporary use permit is automatically revoked if the property is deemed a *nuisance* property under the White Rock Unsightly Premises and Graffiti Abatement Bylaw, 2013, No. 2019;
 - m) Nothing in this temporary use permit shall be construed as authorization for the carrying out of any activity which is a nuisance due to noise, light, odour, emission, vibration or other cause.
5. All definitions of words and phrases contained in Division 8 of the *Local Government Act, R.S.B.C. 2015, Chapter 1* as amended, and the “White Rock Zoning Bylaw, 2012, No. 2000” as amended, shall apply to this Temporary Use Permit and the attachments herein.
 6. This Permit is valid for a period of three years less a day from the date of the authorizing resolution, unless otherwise approved for further time extension by Council in accordance with the provisions of Section 497 of the *Local Government Act*.
 7. Where the holder of this Permit does not obtain required building permits and commence construction of the development as outlined in this Temporary Use Permit within two years after the date this Permit was authorized by Council, the Permit shall lapse, unless the Council, prior to the date the Permit is scheduled to lapse, has authorized further time extension of the Permit.
 8. This permit does not constitute a subdivision approval, a Tree Management Permit, a Demolition Permit, or a Building Permit.

Authorizing Resolution passed by the Council for the City of White Rock on the _____ day of _____, 2020.

This Temporary Use Permit has been executed at White Rock, British Columbia on the _____ day of _____ 2020.

The Corporate Seal of THE CORPORATION OF THE CITY OF WHITE ROCK was hereunto affixed in the presence of:

Mayor - Authorized Signatory

Director of Corporate Administration - Authorized Signatory

Schedule A – Location Map

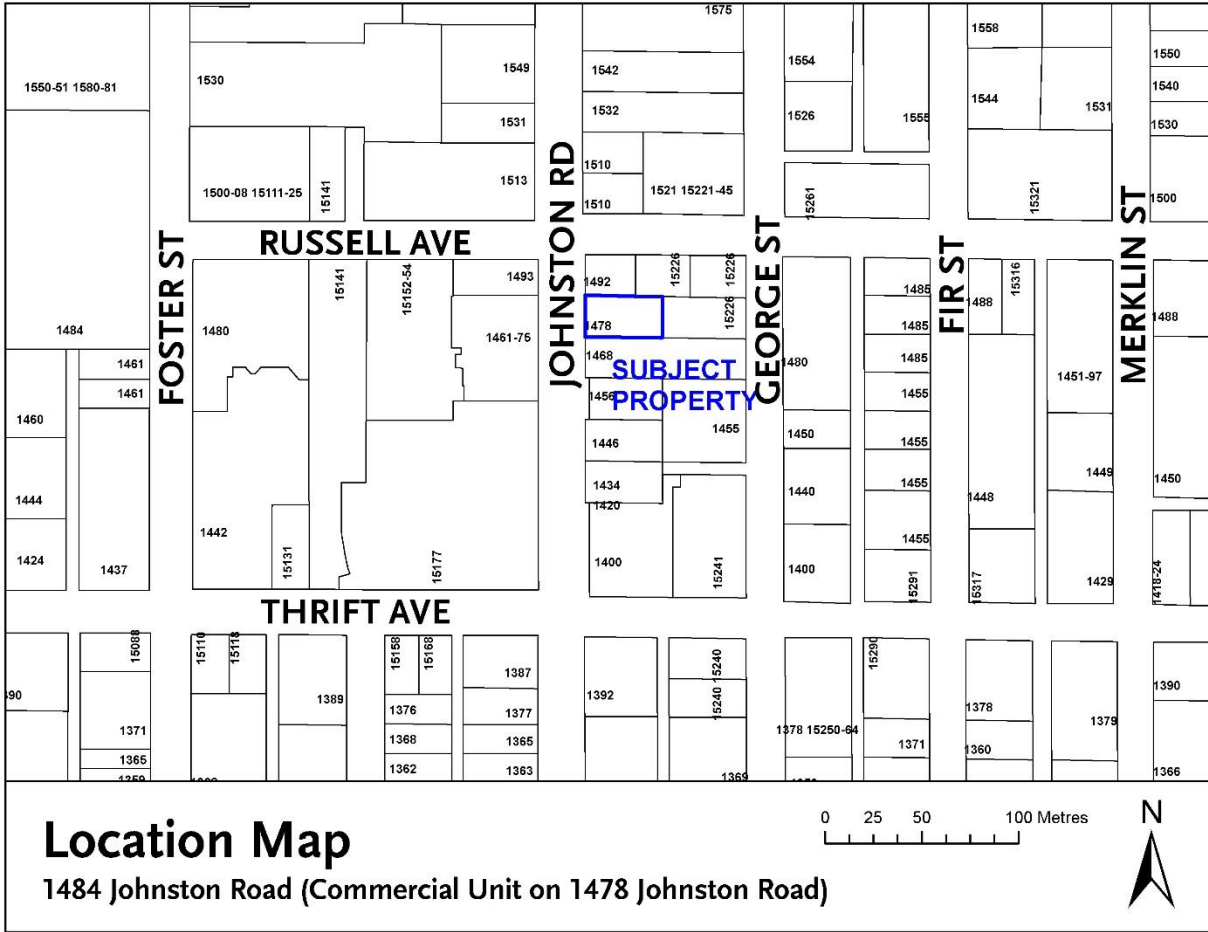

Schedule B – Report dated June 27, 2019 from Aaron Chang, P.Eng, Creative Traffic Solutions, titled “1484 Johnston Road Traffic Engineering Services White Rock, BC



84a moody street
port moody, british columbia
canada v3h 2p5
604.936.6190
604.936.6175
www.cts-bc.com

MEMORANDUM

TO: Randy Tingskou, A Little Bud
FROM: Aaron Chan, P.Eng., CTS
DATE: 27 June 2019
RE: 1484 Johnston Road Traffic Engineering Services
White Rock, BC
FILE NO: 7082-061



Aaron Chan
28 June 2019

Creative Transportation Solutions Ltd. (CTS) is pleased to submit this **FINAL** memo summarizing our findings on the access review at 1484 Johnston Road in the City of White Rock.

The primary objectives of this assignment were as follows:

1. To conduct a site visit to document the existing condition and operation of the access and parking lot at 1484 Johnston Road in the City of White Rock;
2. To review the existing condition and operation of the access and parking lot and determine the appropriate justification to improve the operation and safety of the access and parking lot; and
3. To prepare a brief report summarizing the technical analysis, key findings and Recommendations.

This document summarizes our technical analysis, key findings and recommendations.

1.0 EXISTING CONDITIONS

1.1 Site Visit

CTS conducted a site visit on Monday, June 17, 2019 to observe the existing condition of the access and parking lot at 1484 Johnston Road in the City of White Rock. From the site visit, we summarized the followings:

- The access is located between 1468 and 1478 Johnston Road with an access driveway of approximate 20 meters long and 4.3 meters wide;
- The distance from the curb edge to the building at the frontage of Johnston Road is approximate 3.5 meters, which includes 2 meters of the pedestrian sidewalk and 1.5 meters of the front porch;

- Motorist sight distances to the pedestrian on the sidewalk are limited by the buildings on both side of the access driveway when exiting the access;
- No operation issues were observed for motorist entering the access from Johnston Road;
- The 1484 Johnston Road back parking lot consists of 10 parking stalls and have sufficient space for a typical passenger car to make U-turns when all parking stalls are occupied;
- The 1484 Johnston Road back parking lot is connected to the parking lot of 15226 Russell Avenue with no fence or blockage in between;
- To access the 1484 Johnston Road back parking lot, motorist can use either the access on Johnston Road or the access on George Street (15226 Russel Avenue parking lot access);
- No vehicle was observed to use the parking lot as short-cut through the accesses from/to George Street to/from Johnston Road during the survey period.
- During the site visit between 15:00-16:00, a 30 minutes traffic count was conducted to the study access and parking lot. Only one vehicle was observed to leave the parking lot using the study access.

FIGURE 1 illustrated the photos of study access, access driveway and parking lot behind the building of 1484 Johnston Road.

**FIGURE 1
STUDY ACCESS, ACCESS DRIVEWAY AND BACK PARKING LOT**

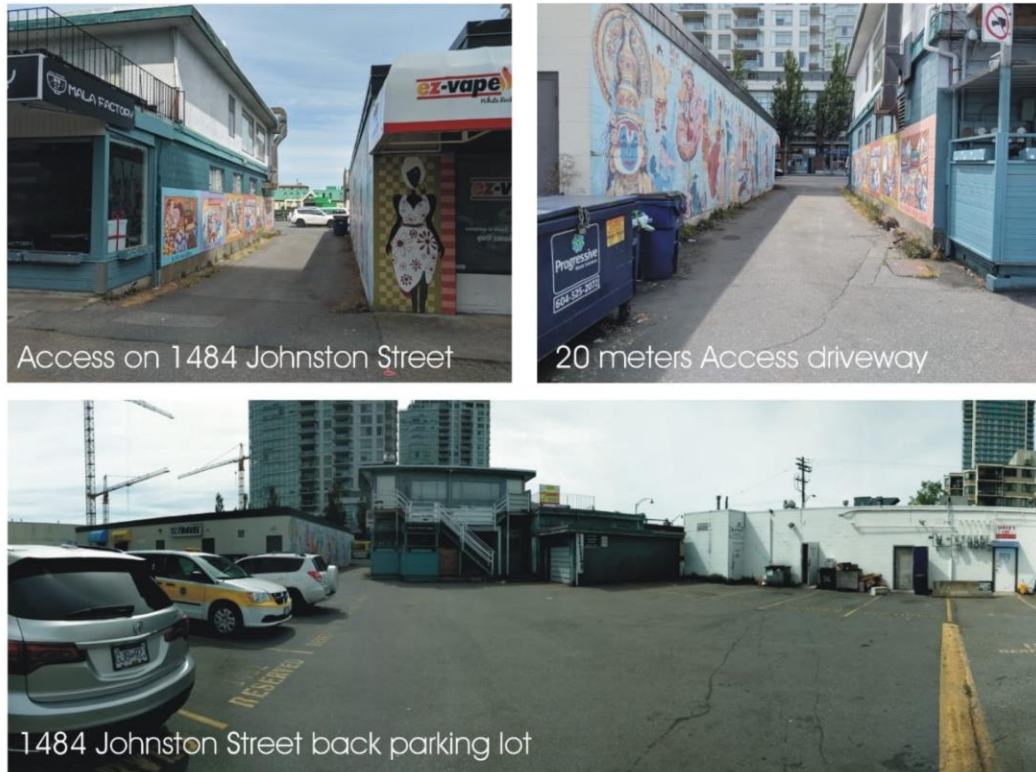

2.0 DISCUSSION AND RECOMMENDATION

2.1 Discussion

From the observation documented in the section above, we noticed that the usage of the study access and parking lot is not significant. No capacity issues were identified. Also, no vehicle was observed to use the parking lot as short-cut through the accesses from/to George Street to/from Johnston Road during the survey period. It is expected that some motorists may use either the access on George Street or Johnston Road to access both the 1478 Johnston Road parking lot and 15226 Russel Avenue parking lot.

It is concerned that the limited motorists' visibility when exiting the access to Johnston Road as the buildings on both sides of the access driveway block the motorists view to the pedestrian on sidewalk at the frontage of 1478 Johnston Road. To mitigate the situation, a speed hump could be used to slow the traffic at the access driveway in addition to a warning and stop signs to warn the motorists to stop for pedestrian crossing ahead on the sidewalk. Also, to improve the motorists' visibility to the pedestrian, a meter-high fences or delineators could be used to block the pedestrian crossing the access at the

front porch area while letting the motorists to advance forward 1.5 meters for better visibility.

It is also concerned that the access driveway width is approximate 4.3 metres, which is not sufficient for two-way traffic at the same time. Based on the current access traffic volume, conflicts between opposite traffic at the access driveway is negligible. No action is required to mitigate the opposite traffic conflicts at the moment. Consideration for mitigation when the access traffic volume is over 30 vehicles per hour.

2.2 Recommendation

Based on the findings, CTS recommended that:

- Installing the speed hump, “Stop” sign, “Pedestrian Crossing” Warning sign to the access driveway;
- Installing 1-meter tall fences or delineators at the front porch on both sides of the access driveway.

FIGURE 2 illustrated the proposed locations of the fences/delineators and speed hump

**FIGURE 2
PROPOSED LOCATION OF THE FENCES/DELINEATORS AND SPEED HUMP**



THE CORPORATION OF THE
CITY OF WHITE ROCK



TEMPORARY USE PERMIT NO. 19-014

1. This Temporary Use Permit No. 19-014 is issued to King Day Holdings Ltd. as the owner (hereinafter called the “Permittee”) and shall apply only to ALL AND SINGULAR those certain parcels or tracts of land and premises situate, lying and being in the City of White Rock, in the Province of British Columbia, and more particularly known and described as:

Legal Description:

Lot 4 Except: The West 7 Feet; Section 11 Township 1 New Westminster District Plan 8437
PID: 007-842-848
(Civic: 1542 Johnston Road)

As indicated on Schedule A

(hereinafter referred to as "the Lands").

2. This Temporary Use Permit No. 19-014 is issued pursuant to the authority of Sections 492 and 493 of the *Local Government Act, R.S.B.C. 2015, Chapter 1* as amended, the “White Rock Zoning Bylaw, 2012, No. 2000” as amended; and in conformity with the procedure prescribed by the “City of White Rock Planning Procedures Bylaw, 2017, No. 2234” as amended.
3. Except as otherwise authorized by this permit, the terms, conditions and guidelines as set out in the "White Rock Zoning Bylaw, 2012, No. 2000" as amended shall apply to the Lands covered by this Temporary Use Permit:
 - a) Permitted Temporary Uses
 - (i) A *cannabis store*

4. Terms and Conditions:

- a) Except as otherwise specified in this permit, all siting, construction, and use shall be in accordance with the provisions of the “White Rock Zoning Bylaw, 2012, No. 2000” as amended;
- b) The permittee must obtain a building permit and comply with the requirements of the BC Building Code for the construction of the interior tenant improvements;
- c) The premises containing the *cannabis store* use must be no larger than 80 square metres;
- d) The permittee must obtain a sign permit;
- e) The permittee must provide a minimum of two on-site parking spaces for the *cannabis store* use;

- f) The *cannabis store* shall not be open to customers prior to 9:00 AM on any day and shall be closed no later than 9:00 PM on any day;
 - g) The *cannabis store* shall not sell any goods or things until it has obtained a valid licence issued in accordance with the *Cannabis Control and Licensing Act*, as amended, and a valid business licence;
 - h) This temporary use permit is automatically revoked if the licence issued in accordance with the *Cannabis Control and Licensing Act*, as amended, is suspended or cancelled;
 - i) This temporary use permit is automatically revoked if the property is deemed a *nuisance* property under the White Rock Unsightly Premises and Graffiti Abatement Bylaw, 2013, No. 2019;
 - j) Nothing in this temporary use permit shall be construed as authorization for the carrying out of any activity which is a nuisance due to noise, light, odour, emission, vibration or other cause.
5. All definitions of words and phrases contained in Division 8 of the *Local Government Act, R.S.B.C. 2015, Chapter 1* as amended, and the “White Rock Zoning Bylaw, 2012, No. 2000” as amended, shall apply to this Temporary Use Permit and the attachments herein.
 6. This Permit is valid for a period of three years less a day from the date of the authorizing resolution, unless otherwise approved for further time extension by Council in accordance with the provisions of Section 497 of the *Local Government Act*.
 7. Where the holder of this Permit does not obtain required building permits and commence construction of the development as outlined in this Temporary Use Permit within two years after the date this Permit was authorized by Council, the Permit shall lapse, unless the Council, prior to the date the Permit is scheduled to lapse, has authorized further time extension of the Permit.
 8. This permit does not constitute a subdivision approval, a Tree Management Permit, a Demolition Permit, or a Building Permit.

Authorizing Resolution passed by the Council for the City of White Rock on the _____ day of _____, 2020.

This Temporary Use Permit has been executed at White Rock, British Columbia on the _____ day of _____ 2020.

The Corporate Seal of THE CORPORATION
OF THE CITY OF WHITE ROCK was hereunto
affixed in the presence of:

Mayor - Authorized Signatory

Director of Corporate Administration - Authorized Signatory

Schedule A – Orthophoto Location Map

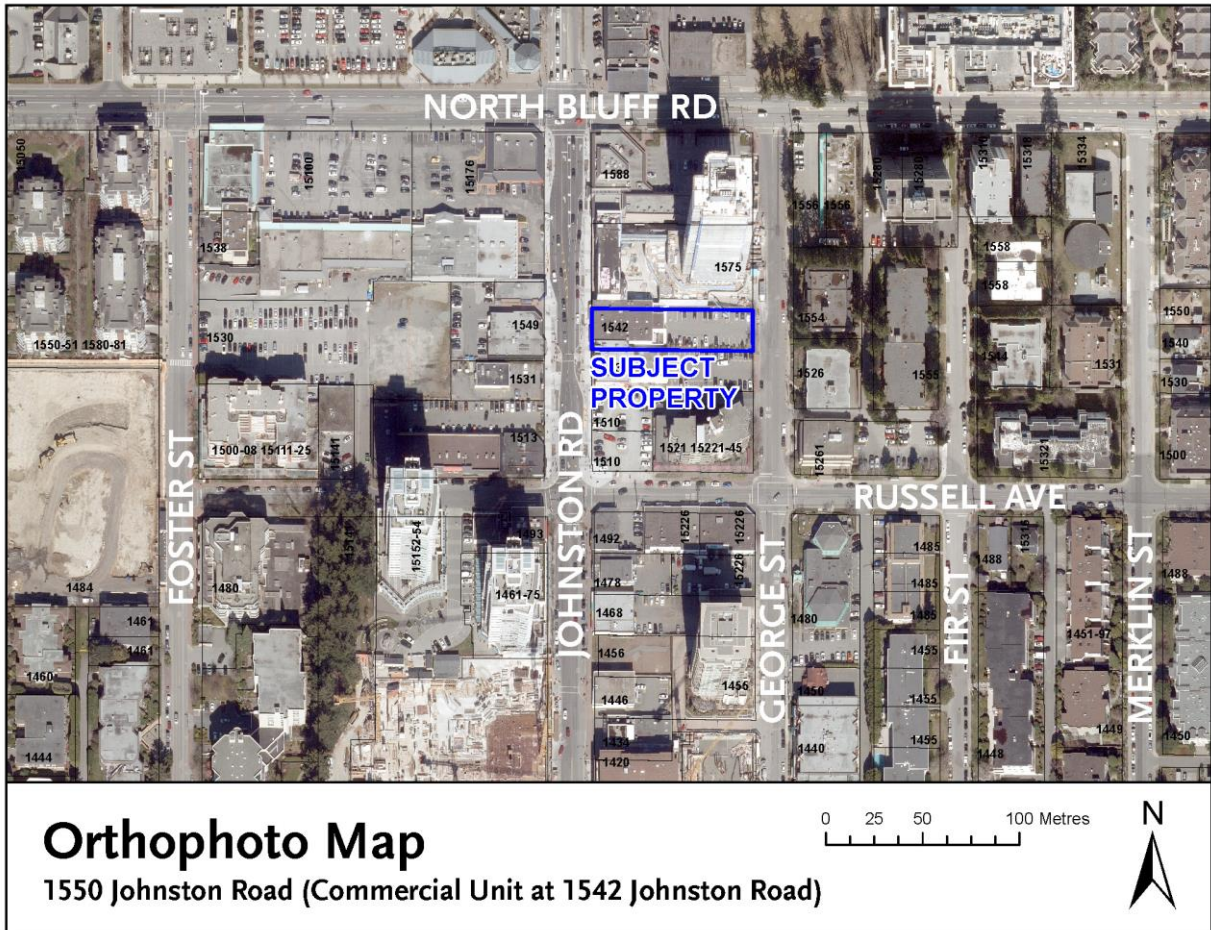

RECEIVED

JAN 07 2019



December 19, 2019

City of White Rock
15322 Buena Vista Avenue
White Rock, BC V4B 1Y6

CITY OF WHITE ROCK
ADMINISTRATION

Dear Mayor & Council,

Thank you for your recent donation of \$2,000.00 in support of Peace Arch Hospice Society, through the 2019 Holiday Home Tour. Your support is greatly appreciated. We have attached your receipt for tax purposes.

Peace Arch Hospice Society serves the residents of the Semiahmoo Peninsula. With your support, we expect to support over 1,000 people in our community who are living with a life-limiting illness or grieving the death of a loved one. Through your generous gift, you too are making a difference in people's lives that is much needed and appreciated.

As our professional counselling services and volunteer programs are offered to the community at *no charge*, we could not offer the range of services we do without the support we receive from individuals, businesses, and community organizations. We have a modest-sized team of professional staff and a dedicated, amazing group of almost 300 volunteers who make a difference every day in the lives of people in our community.

Our steadfast commitment is to offer residents of the Semiahmoo Peninsula the support they need as they face advanced illness and bereavement. To build on this, we are working with Fraser Health and other community groups to enhance hospice care and bereavement support in the White Rock South Surrey area. If you would like more information, please visit our website www.peacearchhospice.org or contact me directly at 604 531-7484. I would be happy to hear from you and thank you again for your support.

Sincerely,

*Thank you so much
for your support!
Beth*

Beth Kish
Executive Director

Official Receipt for Income Tax Purposes

Peace Arch Hospice Society
15435 – 16A Avenue
South Surrey, BC V4A 1T2

Received Date: Dec-18-2019.
Receipt Date: Dec-19-2019

Received From
City of White Rock
15322 Buena Vista Avenue
White Rock, BC V4B 1Y6

Amount Received: \$2,000.00
Pay Method: Cheque

Authorized Signature



LOWER MAINLAND

LOCAL GOVERNMENT ASSOCIATION

TO: Mayor/Chair; Council/Board

FROM: Councillor Jason Lum, Lower Mainland LGA Past President

DATE: January 6, 2020

RE: 2020 CALL FOR NOMINATIONS FOR LOWER MAINLAND LGA EXECUTIVE

Please include the following information on your next meeting agenda.

This circular is notice of the Lower Mainland LGA Executive positions open for nomination, the process and the procedures for nomination.

The deadline for receipt of your nomination is **Friday, March 12, 2020**. The Lower Mainland LGA Conference and AGM will be held from May 6-8, 2020 in Whistler.

The Lower Mainland LGA is the collective voice for local government in the Lower Mainland, including local governments in the Greater Vancouver Regional District, the Squamish-Lillooet Regional District and the Fraser Valley Regional District. The membership elects directors to the Executive during the Convention, and the Executive is charged with ensuring that policy direction set by the general membership is carried forward. The Executive also provides operational and policy direction to the Lower Mainland LGA between Conventions.

1. POSITIONS OPEN TO NOMINATIONS

The following positions are open for nomination:

- President
- First Vice-President
- Second Vice-President
- Third Vice-President
- Directors at Large (3 positions)

2. NOMINATION PROCESS AND QUALIFICATIONS FOR OFFICE

The candidate must be an elected official of a Lower Mainland LGA member. The candidate must be nominated by two elected officials of a Lower Mainland LGA local government member.

Background information regarding the primary responsibilities and commitments of a Lower Mainland LGA Executive member is available upon request.

A nomination and consent form are attached and should be used for all nominations.

The Chair of the 2020 Nominating Committee is Councillor Jason Lum, Lower Mainland LGA Past President.

3. NEXT STEPS

It is part of the duties of the Nominating Committee to review the credentials of each candidate. A Report on Nominations including, at the candidate's option, a photo and 200-word biography will be prepared under the direction of the Nominating Committee and distributed in the Lower Mainland LGA Convention Newsletter, which is distributed via email before the conference and on-site at the conference. It is not the responsibility of the Lower Mainland LGA to edit applicant materials to make them suitable for print. If materials are not provided on time and print ready, the Lower Mainland LGA reserves the right not to include them in the newsletter.

To be included in the Convention Newsletter, send your current photo, biography and completed nomination form to:

sstory@lmlga.ca

**With subject line: Lower Mainland LGA Nomination Package – “applicant name”
Deadline: March 12, 2020**

4. FINAL COMMENTS

The nomination process does not change the process allowing candidates to be nominated off the floor at the Convention. That process remains in place. The process outlined above provides for those that are interested in seeking office to be directly nominated prior to the Convention.

5. FURTHER INFORMATION

All other inquiries should be directed to:

Shannon Story, Executive Director of the Lower Mainland LGA
at sstory@lmlga.ca
PO Box 729
Pemberton, BC V0N 2L0
604 698-5753

NOMINATIONS FOR THE 2020 LOWER MAINLAND LGA EXECUTIVE

We are qualified under the Lower Mainland LGA Constitution to nominate¹ a candidate and we nominate:

Name of nominee: _____

Local government position (Mayor/Councillor/Director): _____

Local government represented: _____

Lower Mainland LGA Executive office nominated for: _____

Printed Name of nominator: _____ Printed Name of nominator: _____

Position: _____ Position: _____

Local Gov't: _____ Local Gov't: _____

Signature: _____ Signature: _____

CONSENT FORM

I consent to this nomination and attest that I am qualified to be a candidate for the office I have been nominated to pursuant to the Lower Mainland LGA Constitution². I also agree to provide the following information to the Executive Director by March 12, 2020:

- 2"x3" Photo (high resolution)
- Biographical information. No more than 200 words in length.

Printed Name: _____

Running for (position): _____

Local Government: _____

Signature: _____

Date: _____

¹ Nominations require two elected officials of members of the Association.
² All nominees of the Executive shall be elected representatives of a member of the Association.

**Return to: ssstory@lmlga.ca
c/o Lower Mainland LGA, PO Box 729, Pemberton, BC V0N 2L0**



LOWER MAINLAND

LOCAL GOVERNMENT ASSOCIATION

TO: Mayor/Chair; Council/Board

FROM: Mayor Jack Crompton, Lower Mainland LGA President

DATE: January 6, 2020 (4 pages total)

RE: 2020 CALL FOR RESOLUTIONS - ANNUAL GENERAL MEETING

Please include the following information on your next meeting agenda.

This circular is a notice of the Lower Mainland LGA Call for Resolutions.

The Lower Mainland LGA Convention and AGM will be held from May 6-8, 2020 in Whistler and we are **now accepting resolutions from the membership**. The deadline for receipt of your resolutions is **Thursday, March 5, 2020**.

We encourage Lower Mainland LGA members to submit their resolutions to the Lower Mainland LGA for debate, rather than submitting them to UBCM. This is also the process preferred by UBCM. Lower Mainland LGA endorsed resolutions on province-wide issues are submitted *automatically* to UBCM for consideration at the UBCM Convention. Resolutions received from the Lower Mainland LGA, and supported by our membership as a whole, tend to hold more weight than those that are submitted by individual communities.

DEADLINE FOR RESOLUTIONS

All resolutions must be received in the LMLGA office by: **THURSDAY, MARCH 5, 2020**

SUBMISSION REQUIREMENTS

Resolutions submitted to the Lower Mainland LGA for consideration shall be submitted as follows:

- one copy of the resolution via email to the Lower Mainland LGA Executive Director Shannon Story at sstory@lmlga.ca with subject header "Resolution-title of your resolution" or, in the case of multiple resolutions, subject header "Resolution-X number enclosed";
- include a cover letter as an attachment outlining how many resolutions you have sent and the title of each resolution;
- each resolution should not contain more than two "whereas" clauses; and
- background documentation must accompany each resolution submitted, and should be labeled "Background-Name of Resolution".

You WILL receive an email notification that your resolution has been received within one week of receipt. If you do not receive an email confirmation, please call Shannon Story at 604-698-5753

Sponsors should be prepared to introduce their resolutions on the Convention floor.

LATE RESOLUTIONS

1. Resolutions submitted following the expiry of the regular deadline (March 5) shall be considered "Late Resolutions" and must comply with all other submission requirements. Please provide a copy of the late resolution as soon as possible to Shannon Story, Executive Director at sstory@lmlga.ca
2. Late resolutions shall be considered for discussion after all resolutions printed in the Resolutions Book have been debated.
3. Late resolutions are deemed to be appropriate for discussion only if the topic is such that it has arisen since or was not known prior to the regular deadline date for submission of resolutions.
4. Late resolutions cannot amend the constitution or bylaws of the Lower Mainland LGA.
5. Late resolutions must receive the approval of 2/3 of Voting Members in attendance at the annual general meeting to be considered.

SUBMIT RESOLUTIONS TO:

**Lower Mainland LGA
Attention: Shannon Story
PO Box 729
Pemberton, BC, V0N 2L0
Email: sstory@lmlga.ca
Phone: (604) 698-5753**

THE RESOLUTIONS PROCESS

1. Members submit their resolutions to Lower Mainland LGA for debate.
2. The Lower Mainland LGA submits the endorsed resolutions of provincial interest to UBCM.
3. The UBCM Resolution Committee reviews the resolutions submitted for consideration at the UBCM Convention.
4. Endorsed resolutions at the UBCM Convention are conveyed to the appropriate order of government, or relevant organization, for responses.
5. Once the responses have been conveyed to the UBCM they are forwarded to the sponsor for their review.

GUIDELINES FOR PREPARING RESOLUTIONS

The Construction of a Resolution:

All resolutions contain a preamble and enactment clause. The preamble describes *the issue* and the enactment clause outlines *the action being requested*. A resolution should answer the following three questions:

- What is the problem?
- What is causing the problem?

- What is the best way to solve the problem?

Preamble:

The preamble commences with a recital, or "WHEREAS", clause. This is a concise sentence about the nature of the problem or the reason for the request. It should clearly and briefly outline the reasons for the resolution.

The preamble should contain no more than two "WHEREAS" clauses. If explaining the problem requires more than two "WHEREAS" clauses, then provide supporting documents to describe the problem more fully. Do not add extra clauses.

Enactment Clause:

The enactment clause begins with the words "THEREFORE BE IT RESOLVED". It must convey the resolution's intent, and should propose a specific action by the Lower Mainland LGA.

Keep the enactment clause as short as possible, and clearly describe the action being requested. The wording should leave no doubt about the proposed action.

How to Draft a Resolution:

1. Address one specific subject in the text of the resolution.

Since your community seeks to influence attitudes and inspire action, limit the scope of a resolution to one specific subject or issue. Delegates will not support a resolution if the issues it addresses are too complex for them to understand quickly.

2. Use simple, action-oriented language and avoid ambiguous terms.

Explain the background briefly and state the desired action clearly. Delegates can then consider the resolution without having to struggle with complicated text or vague concepts.

3. Provide factual background information.

Even a carefully constructed resolution may not clearly indicate the problem or the action being requested. Where possible, provide factual background information to ensure that the "intent" of the resolution is understood.

Two types of background information help to clarify the "intent" of a resolution:

i Supplementary Memo:

A brief, one-page memo from the author, that outlines the background that led to the presentation and adoption of the resolution by the local government.

ii Council/Board Report:

A report on the subject matter, presented to council or board in conjunction with the resolution. If it is not possible to send the entire report, then extract the essential background information and submit it with the resolution.

Resolutions submitted without adequate background information will not be considered until the sponsor has been consulted and has provided documentation outlining the intent of the resolution.

4. Construct a brief, descriptive title.

A title assists to identify the intent of the resolution and eliminates the possibility of misinterpretation. It is usually drawn from the "enactment clause" of the resolution.

For ease of printing in the Annual Report and Resolutions Book and for clarity of intent, a title should be no more than three or four words.

5. Check legislative references for accuracy.

Where necessary, identify:

- the correct jurisdictional responsibility (e.g., ministry or department within the provincial or federal government)
- the correct legislation, including the name of the Act

6. Focus on issues that are relevant to all Lower Mainland members.

The issue identified in the resolution should be relevant to other local governments in the Lower Mainland LGA. This will support proper debate on the issue and assist Lower Mainland LGA or UBCM to represent your concern effectively to the provincial or federal government on behalf of all local governments.

7. Avoid repeat resolutions.

In the past, resolutions have come back year after year on the same topic. Elected officials and staff are encouraged to search the UBCM Resolutions database available through the website at www.ubcm.ca. Click on the “Resolutions and Policy” tab at the top of the page. It will be possible to locate any resolutions on the same topic that have been considered in the past and what the response has been. Endorsed resolutions are part of the advocacy agenda and duplicates are not required.

8. Ensure that your own local government’s process for consideration, endorsement, and conveyance of resolutions to Lower Mainland LGA/UBCM is followed.

MODEL RESOLUTION

SHORT TITLE: _____

Local Government Name _____

WHEREAS _____
_____;

AND WHEREAS _____
_____;

THEREFORE BE IT RESOLVED that _____
_____.

(Note: A second resolve clause if it is absolutely required should start as follows:)

AND BE IT FURTHER RESOLVED that _____
_____.

If you have any questions, please contact Shannon Story by email at sstory@lmlga.ca or by calling (604) 698-5753.

UPDATING AND STRENGTHENING WHITE ROCK'S ENGAGEMENT ON CLIMATE CHANGE

CURRENT POLICY CONTEXT

White Rock's current policy books include a disparate variety of overlapping objectives and action commitments addressing the issue of climate change. All of these can be traced back to the 2007 BC Climate Action Charter under which 187 of BC's 190 municipalities undertook to pursue carbon neutrality in city operations, regularly report on community GHG emissions, and create "complete, compact, more energy efficient rural and urban communities". Building on these commitments:

- The 2008 Environmental Strategic Plan (ESP) laid out several actions to promote energy efficiency and GHG reduction in city facilities and operations and in the community.
- In 2010, the Community Climate Action Plan (CCAP) endorsed the then-prevalent provincial emissions reduction targets (10% below 2007 levels by 2020, 50% by 2050) and prescribed 14 specific actions in 5 areas: land use and development, buildings, transportation, alternative energy supply, and "bridging climate change and sustainability".
- The Official Community Plan (OCP 2008) was amended in 2011 to incorporate the CCAP's commitments, and in 2017 a wholesale revision (OCP 2017) featured an expanded Environmental Management chapter including undertakings: to update GHG reduction targets within 2 years, to take several measures to assess, mitigate and adapt to the risks and consequences of climate change, and to engage actively in Metro Vancouver's air quality initiatives. (The Local Government Act now requires OCPs to include emission reduction targets and policies and actions for their achievement.)

Most recently, at the broader regional district level in July 2019, the Board of Metro Vancouver (on which the Mayor represents White Rock) finalized a Strategic Framework, Climate 2050, setting new emission targets based on the latest UN research and aligned with federal, provincial and many Metro municipality targets (45% below 2010 levels by 2030, carbon neutrality by 2050). Climate 2050 launched a process to develop a series of "Roadmaps" setting goals and actions in 10 areas: ecosystems, infrastructure, health, buildings, transportation, industry, energy, land-use and growth management, agriculture, and waste. Member municipalities are expected to participate in this work.

DEVELOPMENTS IN CLIMATE CHANGE SCIENCE AND POLITICS

In the decade since adoption of the CCAP, scientific consensus on the extent, causes and effects of climate change has strengthened and become effectively unrefuted. The latest research places a pronounced emphasis on the dangers of a collective failure by governments to accelerate and strengthen their policy responses. Drawing on authoritative global, federal and provincial studies, Metro's Climate 2050 highlights several observed consequences and increased risks for this region: prospects of more frequent and more serious droughts, drinking water shortages, wildfires, extreme weather events and rising sea levels all pose heightened threats to infrastructure, ecosystems, human health, recreation and tourism opportunities, and a panoply of other economic and basic security interests.

Alongside the science, public demand for stronger, more effective action has grown significantly. The global campaign for declarations of a "Climate Emergency" is one manifestation of the extent and intensity of public concern. Such declarations have been issued by 1195 jurisdictions in 25 countries, including Parliament and 470 localities in Canada, and counting among them 10 Metro Vancouver municipalities representing 78% of the region's population -- most recently neighbouring Surrey. Pronouncements of this kind can play a significant mobilizing role if they reflect an appreciable degree of public sentiment on which to build. But to be credible, they must also be backed by ambitious and realistic commitments to act.

A WAY AHEAD FOR WHITE ROCK?: MEETING A BIG CHALLENGE WITH LIMITED RESOURCES

Against this background, what are the options for a small municipality, with limited resources and even more limited capability to have an appreciable independent impact on an issue as large and complex as climate change? Given the above-noted developments and challenges, simply continuing with the status quo is not an attractive option for White Rock. This city and its people are no less vulnerable than larger neighbouring communities to the growing threats documented in Climate 2050. Indeed, given the limits of our independent emergency response capabilities, our vulnerability may in many respects be even greater. In such circumstances, the challenge is to deploy whatever tools and resources we can muster to safeguard our citizens and to carry our weight in our broader regional community.

To this end, the Committee proposes an approach entailing the following elements and principles:

- The city's emission reduction targets need updating – this was signaled as an immediate priority in OCP 2017. Our current targets, based on provincial targets extant in 2010, are out of date and out of sync with the latest science and current global, national, provincial and regional targets.
- When updating specific policies, demands arising from grand strategy-review exercises should be limited or streamlined. Given the considerable overlap among the climate change provisions of the ESP, CCAP and OCP, the ongoing OCP Review exercise might offer a useful vehicle to streamline and consolidate the results of any review process. At the same time, it might ensure an opportunity for public input into the development of any new plans or commitments.
- To achieve the maximum practical effect with limited resources in city operations and decisionmaking, climate change considerations should explicitly be mainstreamed into existing core functions and responsibilities, rather than addressed through new standalone programs.
- To ensure that we are pulling our weight, and that our interests and perspectives are taken into account, in the broader regional context, the city could engage as actively as possible in the work recently launched by Metro Vancouver to develop Roadmaps for action in several key sectors.
- The city should also take maximum advantage of an extensive range of existing regional, provincial and extra-governmental programs and resources on offer to inform and support local government climate change efforts (eg, various BC government funding programs such as CARIP, the BC Climate Action Toolkit, UBCM, Federation of Canadian Municipalities, BCMCLC, BARC, FCM).
- While keeping additional costs to a minimum, it is unrealistic to expect an effective mainstreaming strategy to involve no incremental bureaucratic effort or resources. Staff advice should be solicited in this regard. (The CCAP proposed creating a distinct CCAP Program and designating a Program Coordinator -- 1/2 person-year reporting to the Operations Director; and it anticipated a need for some funds for public education, costs of action items within existing departments, and prospective incentive programs. No such organizational or resource measures appear to have been taken to date.)
- Finally, it will be important for the Mayor and Council to stay informed and play an active role in driving the implementation of any strengthened climate change strategy. Annual and 5-year review processes envisaged in the CCAP evidently did not pan out in the face of resource constraints and other priorities. The City has however submitted annual reports to the Province's Climate Action Revenue Incentive Program (CARIP) since 2012. Briefings on these reports may provide one vehicle for keeping Council in the picture and engaged.

Based on the background and considerations outlined above, and a review of climate emergency motions of ten other Metro Vancouver municipalities, the Environmental Advisory Committee proposes the attached draft resolution for consideration by Council.

Based on the background and considerations outlined in the attached report, and a review of climate emergency motions of ten other Metro Vancouver municipalities, the Environmental Advisory Committee proposes the following draft resolution for consideration by Council:

White Rock City Council:

Joins other jurisdictions of Metro Vancouver in recognizing the “climate emergency” arising from critical threats that climate change poses on multiple fronts to regional ecosystems, city infrastructure and the well-being of White Rock’s citizens,

Declares its determination to ensure that the critical interests of White Rock and its citizens are protected and advanced in the fullest possible measure through the City’s climate change mitigation and adaptation strategies,

Requests the Environmental Advisory Committee, working with staff:

- (a) In the context of its mandated review of the Environmental Strategic Plan, to give priority consideration to that Plan’s climate change-related elements, and in so doing to consider also the 2010 Community Climate Action Plan and climate change-related elements of the 2017 OCP.
- (b) To recommend updated emission reduction targets, aligned with targets established by Metro Vancouver in July 2019, and consistent with current provincial and federal goals and the latest IPCC work.
- (c) To recommend steps, including appropriate public consultation measures, to ensure that the City’s climate change goals, policies and actions are updated and consolidated into the Official Community Plan as part of the ongoing OCP review exercise.

Directs staff to:

- (a) Ensure that climate change mitigation and adaptation considerations are mainstreamed into decision-making and operations across all City departments and that climate change impact assessments expressly figure in all reports and recommendations to Council,
- (b) Keep Council apprised of work by Metro officials and committees to develop regional Climate 2050 Roadmaps, and of opportunities and requirements to ensure the City’s interests and perspectives are taken into account in the Roadmaps process,
- (c) Advise Council of any organizational, human resource or financial requirements deemed necessary to ensure the effective implementation of this resolution, as well as opportunities to take advantage of regional, provincial and extra-governmental resources available to inform and support our climate change efforts,
- (d) Keep Council regularly informed of progress in the implementation of this resolution, including through briefings on the City’s annual reports to the Province’s Climate Action Revenue Incentive Program (CARIP).

WHITE ROCK'S RECORD IN ADDRESSING CLIMATE CHANGE AND REDUCING GHG EMISSIONS

The city has since 2012 provided an annual accounting of its efforts to address climate change under the province's Climate Action Revenue Incentive Program (CARIP). See <https://www.whiterockcity.ca/200/Climate-Action-Revenue-Incentive-Program>. Attached are summary compilations of White Rock's CARIP reports dating back to 2014 (prior reports were in a less detailed format) and of the city's GHG inventories 2012-2018.

These reports document numerous measures to promote energy efficiency community-wide and in city operations, and indicate a commendable degree of climate change consciousness on the part of policymakers and administrators alike.

At the same time, they suggest the need for more work if the city is to meet its current or any updated GHG reduction targets anytime soon. In city operations, emission inventories declare significant reductions over the 2012-2015 period and an early, but temporary, achievement of carbon neutrality on the strength of offsets claimed for organic waste composting and other unspecified offsets. However since 2016, measurements have consistently exceeded 2012 figures, and declining offsets have not come close to matching them. (Community-wide emissions inventories do not appear to have been taken since 2012.)

The province's CARIP reporting template also identifies a number of prospective sources of technical support and funding for local governments looking to enhance their climate change efforts.

WHITE ROCK GHG EMISSION INVENTORIES 2012-2018

All data reported in tons of CO2 equivalent (tCO2e)

	2012	2013	2014	2015	2016	2017	2018
CORPORATE GHG EMISSIONS							
From services delivered directly by City government	843	873	796	649	802	786	732
From contracted services	233	238	118	127	398	329	438
TOTAL CORPORATE GHG EMISSIONS FOR YEAR	1076	1111	914	776	1200	1115	1170
EMISSIONS REDUCTIONS CLAIMED							
Energy Efficient Retrofits							
Solar Thermal							
Low Emission Vehicles							
Avoided Forest Conversion							
Household Organic Waste Composting	2073	391	457	411	490	373	348
Metro Landfill Credits				367			
Offsets Acquired for Year (unspecified source)		622	565			0	0
TOTAL REDUCTIONS FOR YEAR	2073	1013	1022	778	490	373	348
NET CORPORATE EMISSIONS FOR YEAR	-997	98	-108	-2	710	742	822
NET REDUCTIONS CARRIED OVER FROM PREVIOUS YEAR	N/A	997	899	1007	1009	382	N/A
CARBON NEUTRALITY STATUS	-997	-899	-1007	-1009	-299	360	822
FUNDING				Yes	Yes	Yes	Yes
Does your local government set aside funds in a climate reserve fund or similar?							
CARIP LEVEL CLAIMED:							
1 – Demonstrating Progress on Charter Commitments							
2 – Measuring GHG Emissions						X	
3 – Accelerating Progress on Charter Commitments							X
4 – Achievement of Carbon Neutrality	X	X	X	X	X		

WHITE ROCK REPORTING UNDER BC CLIMATE ACTION REVENUE INCENTIVE PROGRAM (CARIP) 2014-2018

BROAD PLANNING

Community-Wide Actions Taken

- 2014
 - Revised Tree Management Bylaw to include entire City until new Urban Forest Management Plan is implemented
- 2015
 - Began planning to develop of an Urban Forest Management Plan
 - Supported Fraser Basin Council Society regional flood mgt strategy
 - Completed and published an updated the Strategic Transportation Plan
 - Fine-tuned drainage fee model to reflect individual property characteristics
 - Started the OCP review (developed vision statement and goals)
- 2016
 - Continued work on Official Community Plan
 - Continued support for Fraser Basin Council Society Regional Flood Strategy
- 2017
 - Updated Official Community Plan (OCP) includes goals and strategies related to greenhouse gas reduction and smart growth principles
- 2018
 - Completed marine feasibility study
- Proposed for 2019
 - Reviewing the OCP including greening the City and strengthening transit

Corporate Actions Taken

- 2014
 - East Beach Waterfront Improvements Task Force
- 2015
 - Updated the Development Cost Charges Bylaw
 - Supported the Great Shoreline Clean Up
- 2016
 - Replaced fuel powered ice resurfacers with an electric ice resurfacers
- 2017
 - Updated OCP includes objective for adopting Province's new Energy Step Code
- 2018
 - Continued support for the Coastal Flood Adaption Strategy
- Proposed for 2019
 - Continue to develop corporate GHG reduction strategy

- **Current GHG reduction targets:**

- 10% below 2007 levels by 2020, and 50% below 2007 levels by 2050

- **Plans, policies or guidelines governing climate mitigation in your community?**

- Community Energy and Emissions Plan
- Community- Wide Climate Action Plan
- Official Community Plan
- Regional Growth Strategy

- **Climate reserve fund or something similar? :** Yes (2015, 16, 17, 18 reports)

- **Does your government have a corporate GHG reduction plan?:** In progress (2017, 2018)

BUILDING AND LIGHTING

Community-wide Action

- 2014 - Energy efficient HVAC and window replacement at Librar
- 2015 - Supported use of sustainable building construction methods and materials
- 2016 - Supported Environmental Master Plan which promotes energy efficiency in City facilities, operational activities and the community
- 2017 - Updated OCP includes development of green building strategy
- 2018 - Installed energy efficient street lighting as part of several capital projects
 - 7 civic facilities were assessed for accessibility
- Proposed for 2019
 - Continue conversion of streetlights to LED where possible

Corporate Action

- 2014 - Energy efficient HVAC and roof replacement at City Hall
- 2015 - Completed installation of energy efficient windows at City Hall
 - Upgraded exterior floodlights to high efficiency in one civic facility
 - Continued consultation with BC Hydro on implementation of energy efficient lighting opportunities in civic facilities
 - Installed LED streetlights on a section of Marine Drive
- 2016 - Upgraded from high pressure sodium to energy efficient LED streetlights along a portion of the City’s promenade
- 2017 - Continued replacing lighting with energy efficient lighting at City facilities
 - Upgraded arena ice resurfacers bay facility to use recycled water
- 2018 - Continued replacing lighting with energy efficient lighting in Civic facilities
 - Updated windows and added weather stripping to arts building
- Proposed for 2019:
 - Continue replacing lighting with energy efficient lighting in Civic facilities
 - Update the Facilities Master Plan

- **Is your local government implementing the BC Energy Step Code? : Yes (started 2017?)**

ENERGY GENERATION

Community-wide action

- 2014 - Installed 4 solar powered pedestrian walk signals \
- 2017 - Updated OCP includes objective to support on-site renewable energy systems for electricity, heating, and cooling to buildings and other structures
- 2018 - Installation of public electric vehicle charging stations
- Proposed for 2019: Explore opportunities for additional public EV charging stations

Corporate action

- 2014 - Replaced 3 City vehicles with more fuel efficient models
- 2015 - Added electric vehicles to City fleet
 - Explore solar hot water use in operations building
- 2017 - Updated OCP includes objective to implement Development Permit Area guidelines for energy conservation and greenhouse gas emissions reductions through landscaping, siting of buildings and other structures
- 2018 - New high efficiency boilers installed at three Civic facilities
- Proposed for 2019: Review the use of battery powered outdoor equipment as an alternative to fuel powered equipment to reduce emissions and energy consumption

- Is your government operating, developing, or constructing a **district energy system**, or connected to a district energy system operated by another energy provider? No

- Are you familiar with the 2018 List of **Funding Opportunities for Clean Energy Projects** Led by First Nations and Local Governments? Yes

GREENSPACE

Community Actions

- 2014
 - Enhanced local parks and planted over 125 trees
 - Revised Tree Management Bylaw to include entire City until new Urban Forest Management Plan is implemented
 - Develop signage standard
 - Ongoing support of community gardens
 - Centre Street Walkway Improvements Task Force,
 - Johnston Road Reconstruction & Beautification Task Force
- 2015
 - Supported invasive species task force
 - Supported community gardens program
- 2016
 - Supported invasive species community clean ups
 - Supported community planting of native plants
 - Supported local community garden program
 - Updating Parks and Recreation Master Plan
 - Supported community shore line clean ups
- 2017
 - Supported invasive species community clean ups
 - Supported local community garden program
 - Supported community shore line clean ups
- 2018
 - Constructed of an all-abilities all-ages playground
 - Supported invasive species community clean ups
 - Acquisition of property in town centre to create a public open space
- Proposed for 2019
 - Liaison with community stakeholders on the protection of Semiahmoo Bay
 - Continue planting City street trees

Corporate Action

- 2015
 - Ongoing support of the Lower Mainland Green Team to address local environmental issues that require co-operation and teamwork
 - Ongoing support of the annual Great Canadian Shore Line Clean Up
- 2016
 - Installation of new parks signage
 - Shoreline restoration
 - Began design for upgrades at Memorial Park
- 2017
 - Initiated development of City tree planting program
 - Expanded community gardens
- 2018
 - Updated the Parks and Recreation Master Plan
 - Supported community shore line clean ups
 - Supported local community garden program
 - Developed a high level conceptual design for public open space/town square/gathering space
- Proposed for 2019: Development of a program to inventory and GPS all City trees
- Do you have **urban forest policies, plans or programs?** In progress (2017,2018)
- Policies, plans or programs to support **local food production?** No

SOLID WASTE

Community action

- 2014
 - Additional recyclables added to collection stream
 - Solid waste review/audit completed
 - Continued composter subsidy for residents
 - East Beach Task Force review of waste receptacles
- 2015
 - Provided education and engagement on the region's 2015 ban of organics from waste facilities starting 2015
 - Provided kitchen collectors to encourage organics diversion from solid waste
- 2016-18
 - Continued public education and outreach to improve diversion of solid waste
- 2017-18
 - Updated public waste receptacles to encourage recycling and organics diversion in public spaces
- Proposed for 2019: multi-family and commercial waste collection review and analysis

Corporate action

- 2015
 - Implemented solid waste utility
- 2016
 - Updated recycling receptacles in some civic facilities
- 2017
 - Resident education and outreach to reduce contamination in recyclables
- 2018
 - Initiated program to recycle municipal concrete and asphalt
 - Introduced corporate online services for options for paperless/e-billing
- Proposed for 2019
 - Continue public education and outreach to reduce contamination in recyclables
 - Offer residents kitchen catchers to encourage food scraps diversion

- Does your local government have **construction and demolition waste reduction policies, plans or programs?** Yes

- Does your local government have **organics reduction/diversion policies, plans or programs?** Yes

TRANSPORTATION

Community action

- 2014
 - Improved bike lane on Marine Drive
 - Pedestrian safety improvements in 2 school zones
 - Traffic safety review on Johnston Road
 - Strategic Transportation Plan updated

- 2015
 - Worked with Translink to review the City's transit system to increase ridership
 - Completed 2 railway pedestrian crossings
- 2016
 - Updated bicycle network signage and pavement markings
- 2017
 - Enhanced bicycle network to improve connectivity and increase cycling options
 - Added new sections of sidewalks to encourage more pedestrian traffic
- 2018
 - To encourage walking, cycling and transit use, the Johnston Road revitalization project in the town centre included transit stop designs that support transit improvements over the long term and enhanced intersection and mid block pedestrian crossings with enhanced crosswalk designs
 - Continued work with Translink to make transit more attractive and convenient
- Proposed for 2019
 - Update the Strategic Transportation Plan
 - Installation of additional bike racks to encourage biking

Corporate action

- 2014
 - Provided pedestrian safety fencing along railway tracks
- 2015
 - Extended sections of sidewalk to encourage more pedestrian traffic
 - Public workshops on how to improve vibrancy and functionality of town centre
- 2016
 - Public engagement in revitalizing the town centre
 - Installation of overhead pedestrian crosswalk signal for safety
 - Installation of electric vehicle charging station for new fleet vehicles
- 2017
 - Updated OCP includes objectives to participate and support Metro Vancouver’s Regional Air Quality Management Plan and follow Regional Growth Strategy policies related to reducing transportation- related pollution
- 2018
 - Installation of public electric vehicle charging stations
 - Accessibility improvements at 8 transit stop locations
- Proposed for 2019 : Integrate additional electric vehicles into Civic fleet

- Does your government have policies, **plans or programs to support: Walking, Cycling , Transit Use, Electric Vehicle Use?** Yes to all

- a **Transportation Demand Management (TDM) strategy** (e.g. to reduce single-vehicle occupancy trips, increase travel options, provide incentives to modify travel behaviour)? No

- Does your local government **integrate transportation and land use planning?** Yes

WATER AND WASTEWATER

Community-wide Actions

- 2014 - Review best practices for for stormwater
- 2015 - City acquired the water utility from a private company
 - Completed Water Services Bylaw
- 2016 - Updated Water Conservation Plan
- 2016-18 - Held public meetings/open houses on water quality
 - Communicated water use restrictions through digital and social media channels
- 2018 - Completed Aquifer Protection Plan
- Proposed for 2019
 - Implement key actions identified in the Aquifer Protection Plan
 - Finalize updates to the Storm and Sanitary Systems Master Plan

Corporate actions

- 2016 - Began pilot study on arsenic and manganese treatment options
 - Construction to update reservoir and pumping station
 - Began work to complete secondary disinfection throughout water system
- 2017 - Updated the city's Water Master Plan
 - Implement water leak detection program
 - Initiated aquifer protection plan
 - Upgrades to the drinking water distribution system to reduce main breaks
 - Remote monitoring of drinking water pump stations to provide immediate responses and reduce travel time
 - Improvements in drinking water aesthetics to reduce use of bottled water
- 2018 - Completed pressure monitoring project in the water distribution system
- Proposed for 2019
 - Complete construction of water treatment plant
 - Creation of a community water advisory panel

CLIMATE CHANGE ADAPTATION ACTIONS

- 2016 - Review of Street and Traffic Bylaw
- 2017-18 - Updates to OCP includes objectives to protect the ecological integrity of watercourses and Semiahmoo Bay
 - OCP objective requiring that new buildings within the floodplain are flood-proofed to a standard established by the City and Provincial government
- Proposed for 2019:
 - Advocacy for the protection of Semiahmoo Bay with community stakeholders
 - Continued support for the Coastal Flood Adaption Strategy
www.surrey.ca/city-services/19888

- In 2018 has your government addressed climate change impacts using any of the following?

<ul style="list-style-type: none"> ○ Risk & Vulnerability Assessments Y ○ Reduction Strategies Y ○ Emergency Response Planning Y ○ Asset Management N ○ Natural/Eco Asset Management Strategies N ○ Infrastructure Upgrades Y ○ Beach Nourishment Projects N ○ Economic Diversification Initiatives N ○ Strategic and Financial Planning Y 	<ul style="list-style-type: none"> ○ Cross-Department Working Groups Y ○ OCP Policy Changes Y ○ Changes to Zoning and other Bylaws and Regulations Y ○ Incentives for Property Owners (e.g. reducing storm water run-off) Y ○ Public Education and Awareness Y ○ Research Y ○ Mapping N ○ Partnerships Yes
---	--

- **Resources that may be helpful to local government** (Reports indicate none used.):

- | | |
|---|--|
| <ul style="list-style-type: none"> ○ Indicators of Climate Change for BC ○ Plan2Adapt ○ Metro Vancouver Climate Projections ○ Province’s BC Adapts Video Series ○ Preparing for Climate Change: Implementation Guide for Local Governments | <ul style="list-style-type: none"> ○ Public Infrastructure and Engineering Vulnerability Committee’s (PIEVC) ○ Sea Level Rise Adaptation Primer ○ BC Regional Adaptation Webinars ○ Retooling for Climate Change ○ Water Balance Model ○ Water Conservation Calculator |
|---|--|
-
- Funding:

<ul style="list-style-type: none"> ▪ National Disaster Mitigation Program (NDMP) ▪ Community Emergency Preparedness Fund (CEPF) ▪ Municipalities for Climate Innovation Program (MCIP) 	<ul style="list-style-type: none"> ▪ Climate Adaptation Partner Grants (FCM) ▪ Infrastructure Planning Grants (MAH) ▪ Federal Gas Tax Fund ▪ Programs, Partnerships and Funding Opportunities
---	---



**PEACE ARCH
HOSPITAL
FOUNDATION**

The heart of a healthy community

ON TABLE
2020-01-13 Regular Council
Re Item 5.1.1

Peace Arch Hospital and Community Health Foundation

Presented by:

Stephanie Beck, Executive Director

Geoff Funke, Board Chair





**PEACE ARCH
HOSPITAL
FOUNDATION**

The heart of a healthy community

History



Built in 1954 as a 47-bed community hospital.





**PEACE ARCH
HOSPITAL
FOUNDATION**

The heart of a healthy community

Peace Arch Hospital



- One of 12 acute-care hospitals located within the Fraser Health Authority.



PAH Foundation

- Established in 1988
- Over \$150 M in revenue raised and invested into the local community
- Imagine Canada Accreditation – one of the first hospital foundations in Canada to receive this accreditation



PAH Hospital & Community Health Foundation

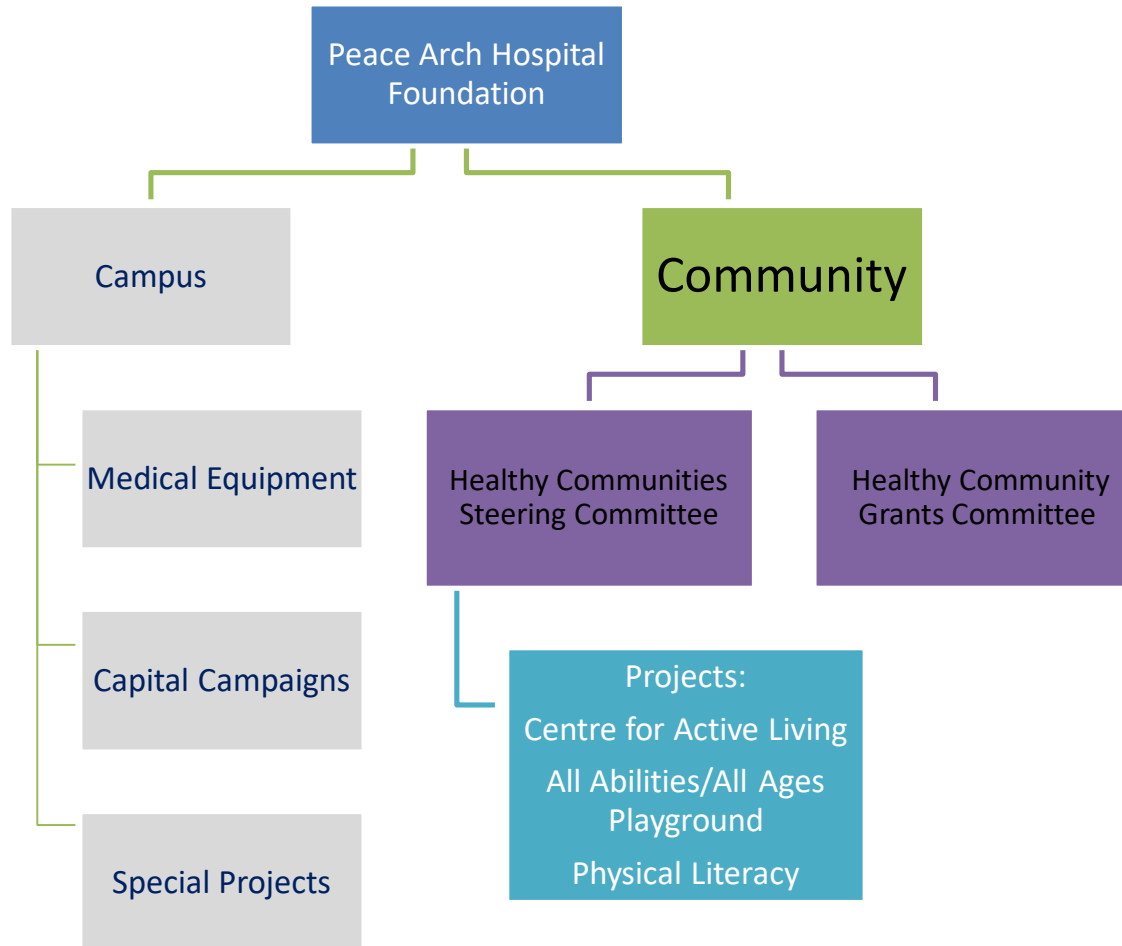



**PEACE ARCH
HOSPITAL
FOUNDATION**

The heart of a healthy community

PAH Foundation Lodge & George and Sylvia Melville Hospice Home



- \$46 million project
- \$10 million raised by the community
- \$35 million financed by the Foundation
- Opening in April 2020



Expanded Emergency Department and 5 New Surgical Suites



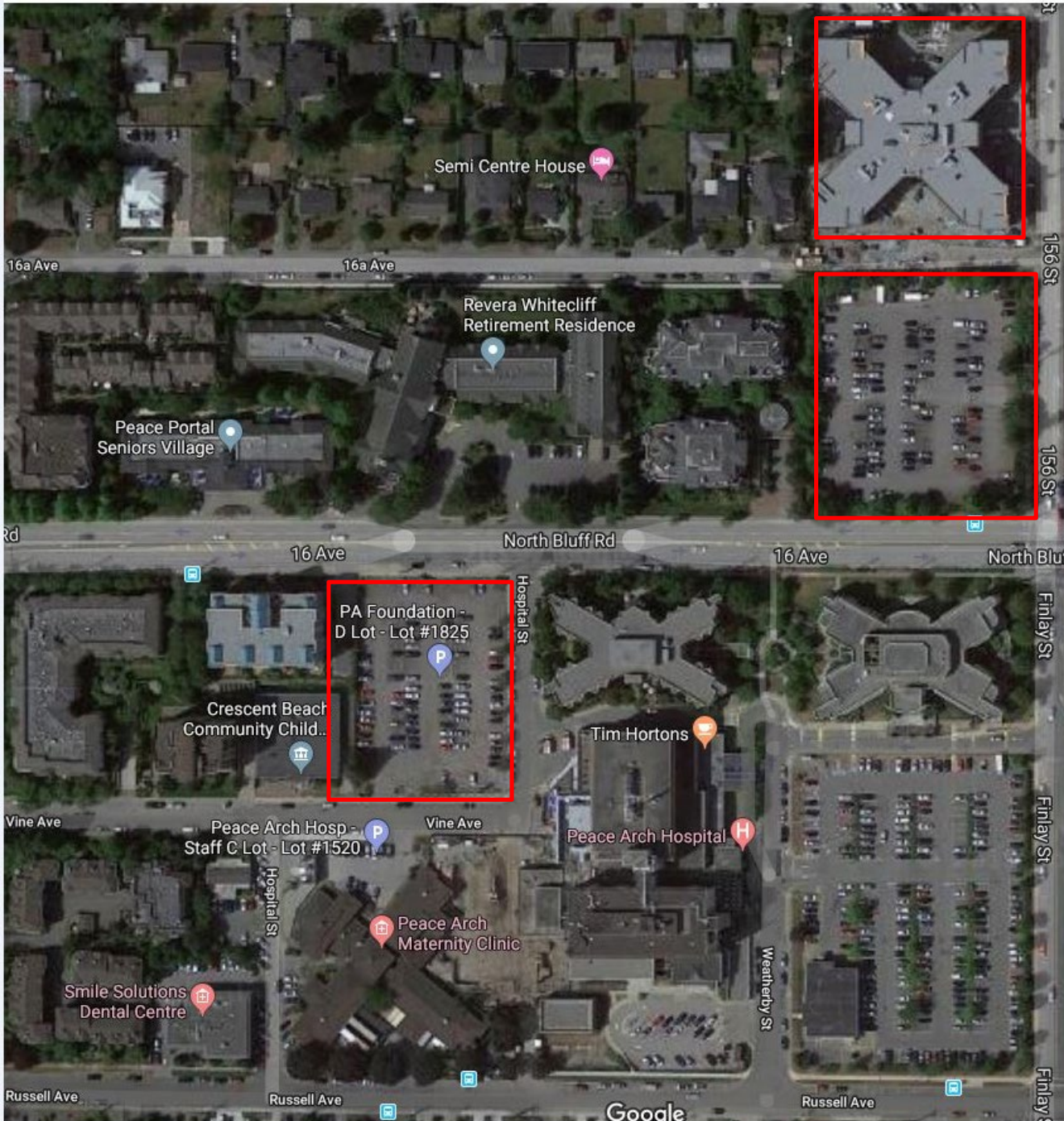

PAH Foundation Lodge

Foundation - Parking Lot C

Foundation - Parking Lot D



**PEACE ARCH
HOSPITAL
FOUNDATION**

The heart of a healthy community

Healthy Community

Geoff Funke, Board Chair





Physical Literacy

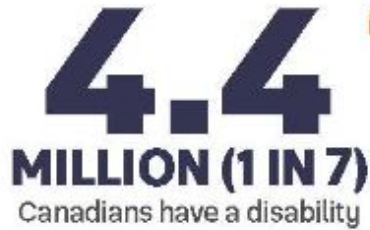
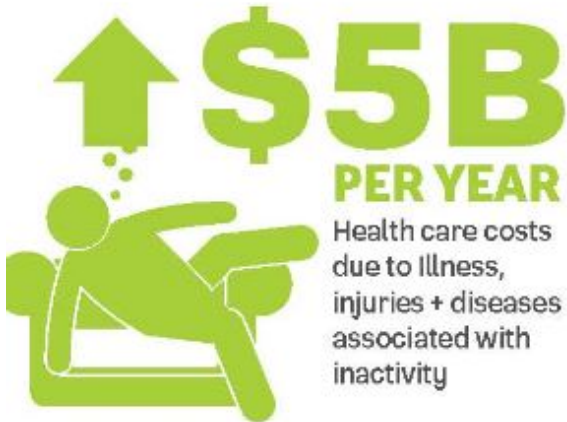

ON AVERAGE, AN INACTIVE PERSON SPENDS

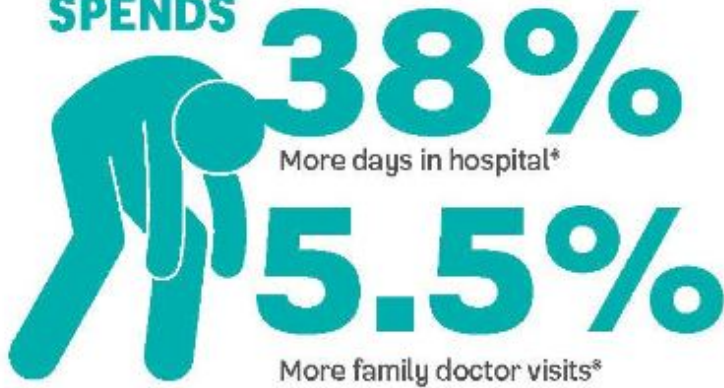

*Compared to an active person



Project Goals

- Change physical activity behaviour through targeted communications and increased awareness
- Deliver creative, safe, inclusive and effective physical activity and programs
- Integrate and coordinate expertise across sectors to create cross-sectoral solutions
- Develop sustainable programs to have ongoing impact in the community
- Improve the competence, confidence and motivation of 33,000 community members to be physically active for life



**PEACE ARCH
HOSPITAL
FOUNDATION**

The heart of a healthy community

Generations Playground

**ALL
ABILITIES
ALL AGES
PLAY
GROUND**



Healthy Community Grants

Healthy Community Grant Recipients Include:		
Volunteer Cancer Drivers	Sources Dental Clinic	Semiahmoo Family Place
Options Community Services	SSWR Early Years Centre	Alexandra Neighborhood House
City Care Dental	Avalon Women's Society	Pacific Postpartum Support Society
WRSS Stroke Recovery Branch	Seniors Health Network	Semiahmoo Seniors Planning Table
Peace Arch Elementary PAC	Seniors Come Share	Youth Vine Clinic

So far in 2019-2020, \$92,500 has been granted.



**PEACE ARCH
HOSPITAL
FOUNDATION**

The heart of a healthy community

**Thank You &
Questions?**



Regular Council Meeting – On Table
Monday, January 13, 2020
New Item: 13.1

13.1 APPOINTMENT OF COUNCIL LIAISONS

RECOMMENDATION

THAT Council appoints of the following representatives:

- a) Arts & Cultural Advisory Committee
 - Councillor Representative: Councillor Manning
- b) Public Art Advisory Committee:
 - Councillor Representative: Councillor Trevelyan
- c) Tour de White Rock Committee:
 - Council Representative: Councillor Johanson